

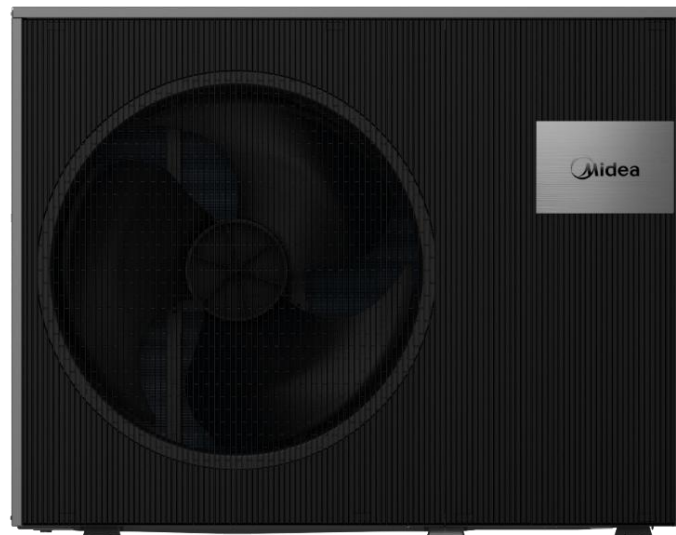

Midea Building Technologies Division

Engineering Reference Manual

M thermal Nature Plus Series



CONTENTS

Part 1 General Information.....	3
Part 2 Engineering Data	19

Part 1

General Information

1 R290 M thermal Mono System	4
2 Product Lineup	6
3 Nomenclature.....	7
4 System Design and Unit Selection	8
5 Typical Applications	10

1 R290 M thermal Mono System

1.1 System Schematic

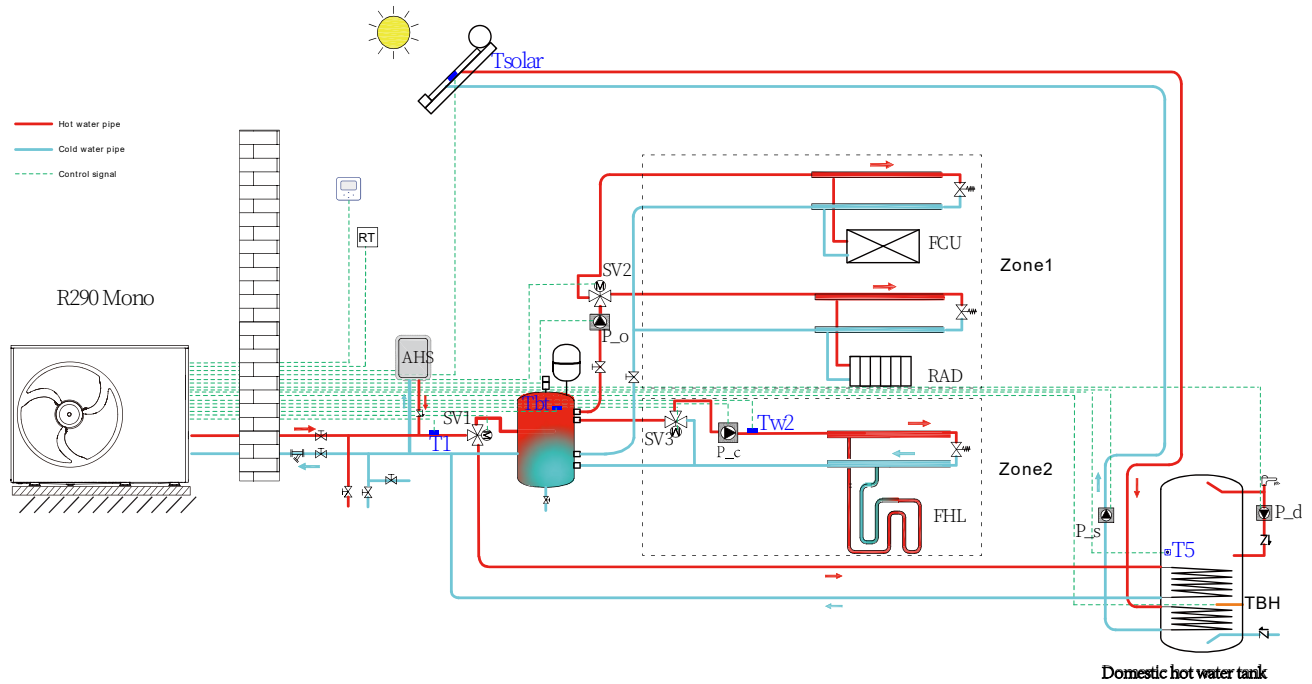

R290 M thermal is an integrated air to water heat pump system and a one-stop solution for space heating, space cooling and domestic hot water, The outdoor heat pump system extracts heat from the outdoor air and transfers this heat through refrigerant piping to the plate heat exchanger in the hydronic system. The heated water in the hydronic system circulates to low temperature heat emitters (floor heating loops or low temperature radiators) to provide space heating, and to the domestic hot water tank to provide domestic hot water. The 4-way valve in the outdoor unit can reverse the refrigerant cycle so that the hydronic system can provide chilled water for cooling by fan coil units.

The heating capacity of heat pumps decreases as the ambient temperature drops. R290 M thermal Mono can be equipped with a backup electric heater to provide additional heating capacity for use during extremely cold weather when the heat pump capacity alone is insufficient. The backup electric heater serves as a secondary heat source in the event of a heat pump malfunction and also prevents the external water pipes from freezing during winter.

1.2 System Configurations

R290 M thermal Mono can be configured to run with the electric heater either enabled or disabled and can also be used in conjunction with an auxiliary heat source such as a boiler.

The chosen configuration affects the size of heat pump required. Three typical configurations are described below.

Configuration 1: Heat pump only

- The heat pump covers the required capacity with no additional heating capacity required.
- Requiring larger capacity heat pump implies higher initial investment in most cases.
- Ideal for new construction or other projects where energy efficiency is paramount.

Configuration 2: Heat pump and backup electric heater

- Heat pump provides required capacity until ambient temperature drops below the point at which the heat pump alone is sufficient. At this point, the backup electric heater engages to cover the heating capacity shortfall. (see diagram below)
- Optimal balance between initial investment and operating costs, ensuring lowest cost of ownership.
- Ideal for new construction.

Configuration 3: Heat pump with auxiliary heat source

- Heat pump provides required capacity until ambient temperature drops below the point at which the heat pump alone is sufficient. In such cases, the auxiliary heat source either provides the necessary supplemental heating capacity or takes over for the heat pump, depending on the system settings. (see diagram below)
- Enables selection of lower capacity heat pump.
- Ideal for remodeling and upgrades.

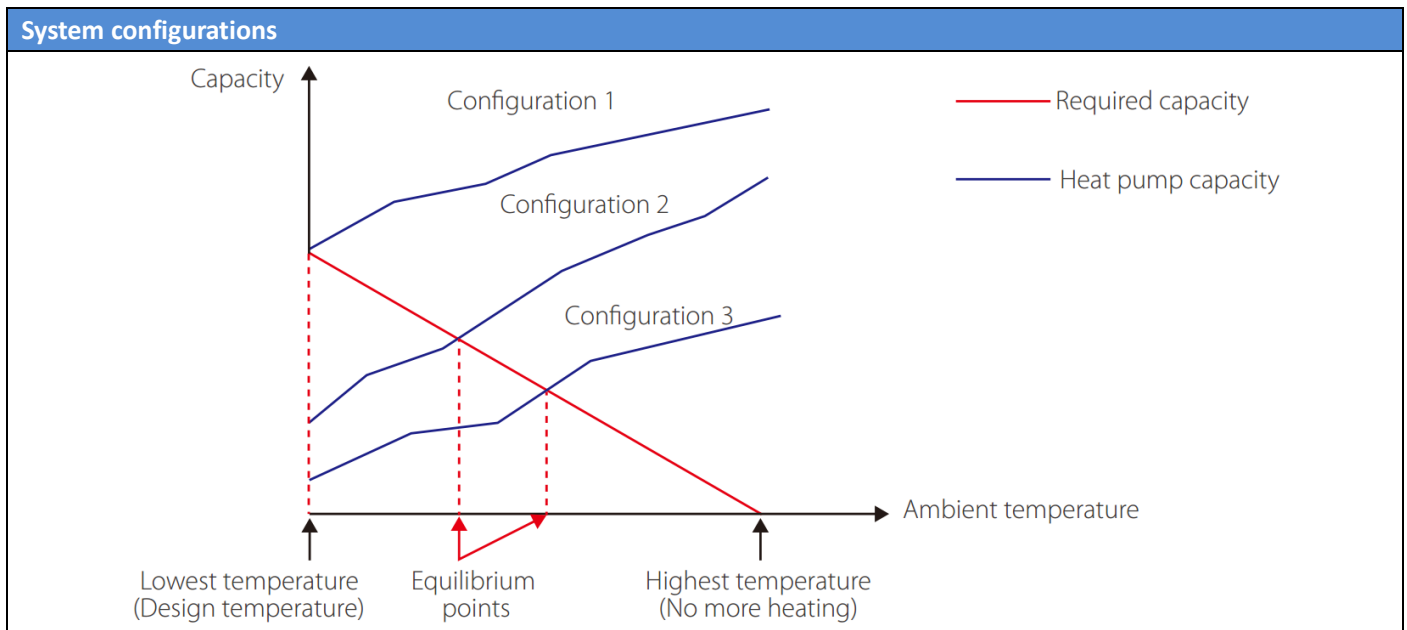

2 Product Lineup

Unit Power Supply	220-240V/1N/50Hz				
Model	MHC-V8WD2N7-B2	MHC-V10WD2N7-B2	MHC-V12WD2N7-B2	MHC-V14WD2N7-B2	MHC-V16WD2N7-B2
Model With backup E-heater 3KW	MHC-V8WD2N7-B2E30	MHC-V10WD2N7-B2E30	MHC-V12WD2N7-B2E30	MHC-V14WD2N7-B2E30	MHC-V16WD2N7-B2E30
Model With backup E-heater 6KW	MHC-V8WD2N7-B2ER60	MHC-V10WD2N7-B2ER60	MHC-V12WD2N7-B2ER60	MHC-V14WD2N7-B2ER60	MHC-V16WD2N7-B2ER60
Model With backup E-heater 9KW	MHC-V8WD2N7-B2ER90	MHC-V10WD2N7-B2ER90	MHC-V12WD2N7-B2ER90	MHC-V14WD2N7-B2ER90	MHC-V16WD2N7-B2ER90
Appearance					

Unit Power Supply	380-415V/3N/50Hz				
Model	MHC-V8WD2RN7-B2	MHC-V10WD2RN7-B2	MHC-V12WD2RN7-B2	MHC-V14WD2RN7-B2	MHC-V16WD2RN7-B2
Model With backup E-heater 3KW	MHC-V8WD2RN7-B2E30	MHC-V10WD2RN7-B2E30	MHC-V12WD2RN7-B2E30	MHC-V14WD2RN7-B2E30	MHC-V16WD2RN7-B2E30
Model With backup E-heater 6KW	MHC-V8WD2RN7-B2ER60	MHC-V10WD2RN7-B2ER60	MHC-V12WD2RN7-B2ER60	MHC-V14WD2RN7-B2ER60	MHC-V16WD2RN7-B2ER60
Model With backup E-heater 9KW	MHC-V8WD2RN7-B2ER90	MHC-V10WD2RN7-B2ER90	MHC-V12WD2RN7-B2ER90	MHC-V14WD2RN7-B2ER90	MHC-V16WD2RN7-B2ER90
Appearance					

3 Nomenclature

M	H	C	-	V	16	W	D2	R	N7	-	B2	E	R	90
1	2	3		4	5	6	7	8	9		10	11	12	13

Legend		
No.	Code	Remarks
1	M	Brand: Midea
2	H	Unit type: heat pump
3	C	Structure: Mono
4	V	System type: Inverter
5	16	Capacity Code: 8: 8 kW; 10: 10 kW; 12: 12 kW; 14: 14 kW; 16: 16 kW;
6	W	Cooling type: Air cooling
7	D2	Compressor and fan motor types: All DC
8	R	Heat Pump Power Supply R: 3-phase, 380-415V, 50Hz; Omitted: 1-phase, 220-240V, 50Hz
9	N7	Refrigerant: R290
10	B2	Version code Omitted: First-generation product
11	E	E-heater Omitted: without E-heater
12	R	E-heater Power Supply R: 3-phase, 380-415V, 50Hz; Omitted: 1-phase, 220-240V, 50Hz
13	90	E-heater power 9KW

4 System Design and Unit Selection

4.1 Selection Procedure

Step 1: Total heat load calculation

Calculate conditioned surface area.
 Select the heat emitters (type, quantity, water temperature and heat load).

Step 2: System configuration

Decide whether to include AHS and set AHS's switching temperature.
 Decide whether backup electric heater is enabled or disabled.

Step 3: Selection of outdoor units

Determine required total heat load on outdoor units.
 Set capacity safety factor.
 Select power supply.

Provisionally select R290 M thermal Mono unit capacity based on nominal capacity.

Adjust capacity of the outdoor units for the following items:
 Outdoor air temperature / Outdoor humidity / Water outlet temperature¹ /
 Altitude / Anti-freeze fluid.

Is corrected R290 M thermal Mono unit capacity \geq Required total heat load on outdoor units.²

Yes
 R290 M thermal Mono system selection is complete

No
 Select a larger model or enable backup electric heater operation

Notes:

1. If the required water temperatures of the heat emitters are not all the same, the R290 M thermal Mono's outlet water temperature setting should be set at the highest of the heat emitter required water temperatures. If the water outlet design temperature falls between two temperatures listed in the outdoor unit's capacity table, calculate the corrected capacity by interpolation.
2. If the outdoor unit selection is to be based on total heating load and total cooling load, select Mono units which satisfy not only the total heating load requirements but also the total cooling load requirements.

4.2 Selection tool

Midea Heat pump selection website: <https://www.midea-hpselection.com>

Easy selection: For quick and simple unit selection without registration

Professional selection: For detailed and professional unit selection with registration and authorization.

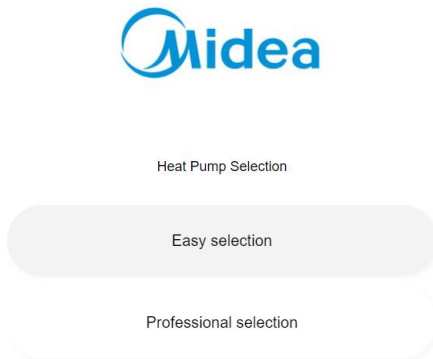

4.3 R290 M thermal Leaving Water Temperature (LWT) Selection

The recommended LTW ranges for different types of heat emitters are as follows:

- For floor heating: 30 to 35°C
- For fan coil units: 30 to 45°C
- For low temperature radiators: 40 to 50°C

4.4 Optimizing System Design

To get the most comfort with the lowest energy consumption with Heat Pump, it is important to take account for the following:

- Choose heat emitters that allow the heat pump system to operate at as low a hot water temperature as possible while still providing sufficient heating.
- Make sure the selected weather dependency curve matches the installation environment (building structure, climate) as well as end user's demands.
- Utilizing a room thermostat (supplied by user) to the hydronic system helps prevent excessive space heating by stopping the outdoor unit and circulation pump when the room temperature is above the thermostat set point.

5 Typical Applications

5.1 Controlled through the user interface

You can set the water temperature, room temperature, and double-zone control on the wired controller. Three options: WATER FLOW TEMP, ROOM TEMP, DOUBLE ZONE (The User interface >> For Serviceman >> Temp. type setting).

5.1.1 Single-zone control

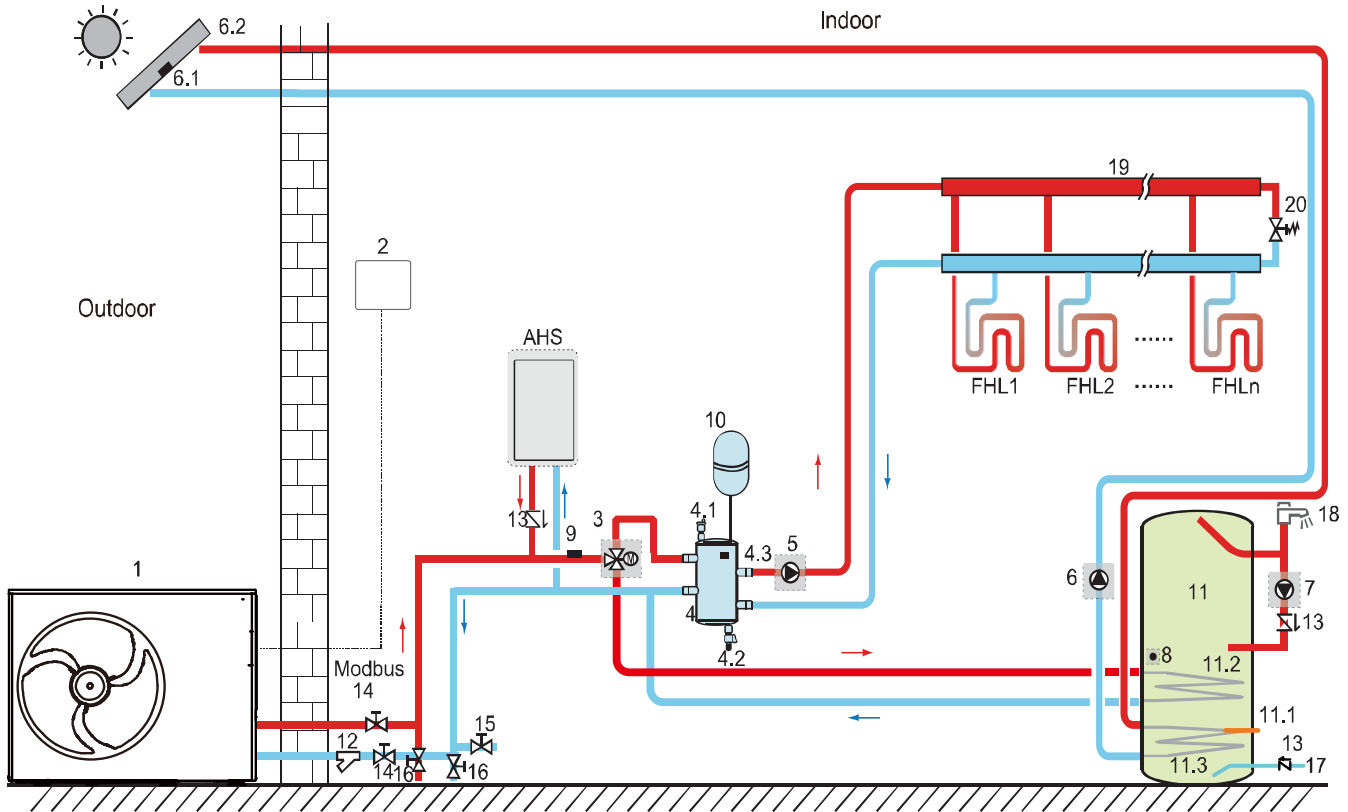

Legend			
1	Main Unit	11	Domestic hot water tank (Supplied by the user)
2	User interface	11.1	TBH: Domestic hot water tank booster heater (Supplied by the user)
3	SV1:3-way valve (Supplied by the user)	11.2	Coil 1, heat exchanger for heat pump
4	Balance tank (Supplied by the user)	11.3	Coil 2, heat exchanger for Solar energy
4.1	Automatic air purge valve	12	Filter (Accessory)
4.2	Drainage valve	13	Check valve (Supplied by the user)
4.3	Tbt: Temperature sensor of balance tank (Optional)	14	Shut-off valve (Supplied by the user)
5	P_o: Outside circulation pump (Supplied by the user)	15	Filling valve (Supplied by the user)
6	P_s: Solar pump (Supplied by the user)	16	Drainage valve (Supplied by the user)
6.1	Tsolar: Solar temperature sensor (Optional)	17	Tap water inlet pipe (Supplied by the user)
6.2	Solar thermal collector (Supplied by the user)	18	Hot water tap (Supplied by the user)
7	P_d: DHW pipe pump (Supplied by the user)	19	Collector/distributor (Supplied by the user)
8	T5: Temperature sensor of domestic water tank (Accessory)	20	Bypass valve (Supplied by the user)
9	T1: Final Water flow temperature sensor (Optional)	FHL1...n	Floor heating loop (Supplied by the user)
10	Expansion vessel (Supplied by the user)	AHS	Auxiliary heat source (Supplied by the user)

Notes:

1. The example is just for application illustration; please confirm the exact installation method according to the installation manual.
2. A bypass valve must be installed to make water recirculation possible when all shut-off valves are closed.

Space heating

The ON/OFF signal, operation mode, and temperature are set on the user interface. P_o keeps running as long as the unit is ON for space heating, while SV1 remains OFF.

Domestic water heating

The ON/OFF signal and target tank water temperature (T5S) are set on the user interface. P_o stops running as long as the unit is ON for domestic water heating while SV1 remains ON.

AHS (auxiliary heat source) control

The AHS function is set on the HMI (for maintenance personnel).

1) When the AHS is set to be valid only for heating mode, AHS can be turned on in the following ways:

- a. Turn on the AHS via BACKUP HEATER function on the user interface;
- b. AHS will be turned on automatically if the initial water temperature is too low or the target water temperature is too high at low ambient temperature.

P_o keeps running as long as the AHS is ON while SV1 remains OFF

2) The AHS is set to be valid for heating and DHW modes. In heating mode, AHS control is the same as item 1) listed above; In DHW mode, AHS will be turned on automatically when the initial domestic water temperature T5 is too low or the target domestic water temperature is too high at low ambient temperature. P_o stops running while SV1 remains ON.

3) When the AHS is set to be valid, M1M2 can be set to be valid on the user interface. In heating mode, AHS will be turned on when the M1M2 dry contact closes. This function is invalid in DHW mode.

TBH (tank booster heater) control

The TBH function is set on the user interface.

1) When the TBH is set to be valid, TBH can be turned on via TANK HEATER function on the user interface; In DHW mode, TBH will be turned on automatically when the initial domestic water temperature T5 is too low or the target domestic water temperature is too high at low ambient temperature.

2) When the TBH is set to be valid, M1M2 can be set to be valid on the user interface. TBH will be turned on when the M1M2 dry contact closes.

Solar energy control

The unit recognizes solar energy signals by judging Tsolar or receiving SL1SL2 signals from the user interface. The recognition method can be set via *Solar function* & *Solar control* on the user interface. (The User interface >> For Serviceman >> Other heat source >> Solar function & Solar control).

1) When Tsolar is set to be valid, solar energy turns ON when Tsolar is high enough, and P_s starts running; Solar energy turns OFF when Tsolar is low. and P_s stops running.

2) When SL1 SL2 control is set to be valid, solar energy turns ON after receiving solar kit signals from the user interface, and P_s starts running; If no solar kit signals are received, solar energy turns OFF, and P_s stops running.

5.1.2 Double-Zone control

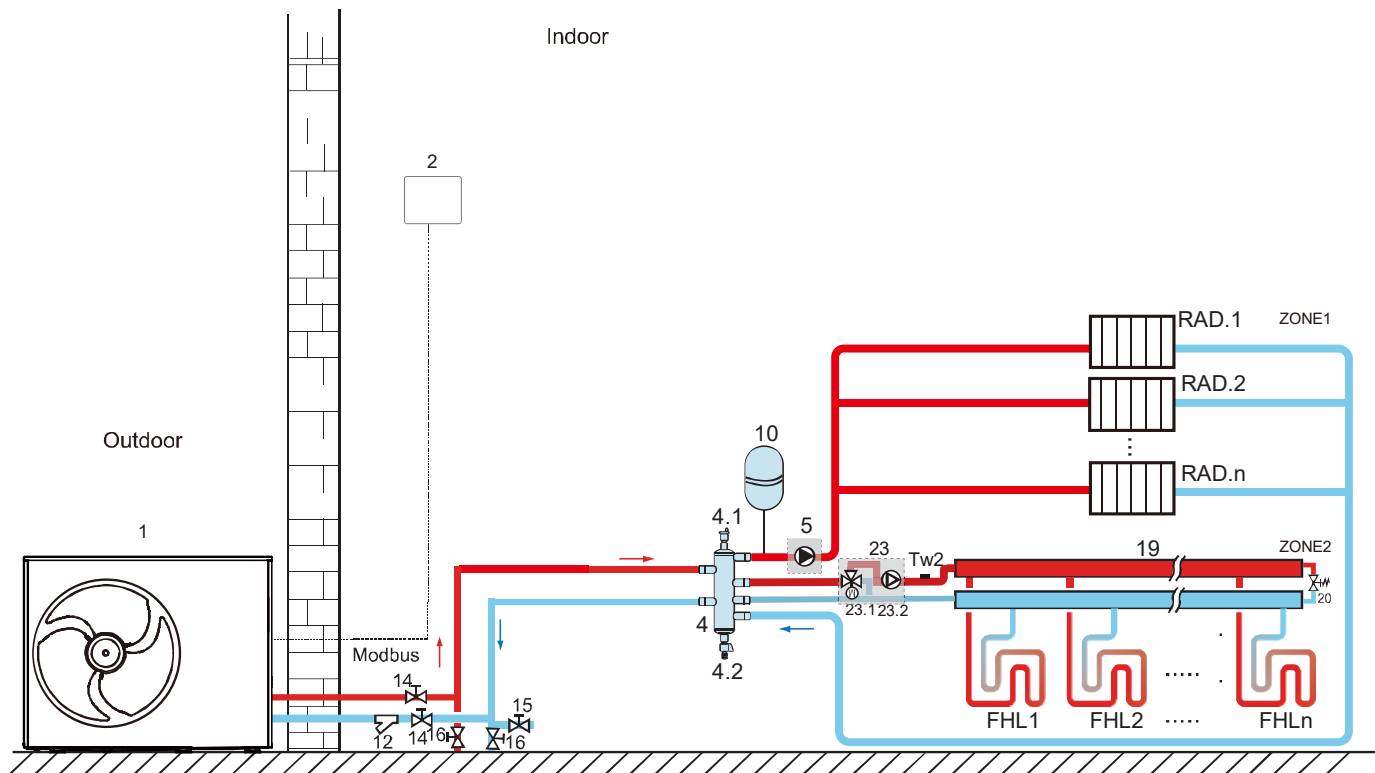

Legend			
1	Main Unit	16	Drainage valve (Supplied by the user)
2	User interface	19	Collector/distributor (Supplied by the user)
4	Balance tank (Supplied by the user)	20	Bypass valve (Supplied by the user)
4.1	Automatic air purge valve	23	Mixing station (Supplied by the user)
4.2	Drainage valve	23.1	SV3: Mixing valve (Supplied by the user)
5	P_o: Zone1 circulation pump (Supplied by the user)	23.2	P_c: Zone 2 circulation pump (Supplied by the user)
10	Expansion vessel (Supplied by the user)	Tw2	Zone 2 water flow Temperature sensor (Optional)
12	Filter (Accessory)	FHL1...n	Floor heating loop (Supplied by the user)
14	Shut-off valve (Supplied by the user)	RAD.1...n	Radiator(Supplied by the user)
15	Filling valve (Supplied by the user)		

Notes:

1. The example is just for application illustration; please confirm the exact installation method according to the installation manual.
2. A bypass valve must be installed to make water recirculation possible when all shut-off valves are closed.

Space heating

The ON/OFF signal, operation mode, and temperature are set on the user interface. Zone1 can operate in cooling mode or heating mode, while Zone 2 can only operate in heating mode; During operation, Zone1 is controlled by Final Water flow temperature (T1), Zone2 is controlled by Zone2 water outlet temperature(Tw2) or room temperature(Ta).

Circulation pump operation

When Zone1 turns ON, P_o starts running; When Zone1 turns OFF, P_o stops running;

When Zone2 turns ON, SV3 switches between ON and OFF according to the set TW2, and P_c remains ON; When Zone 2 turns OFF, SV3 remains OFF and P_c stops running.

The floor heating loops require a lower water temperature in heating mode than radiators or fan coil units. To reach the set temperature points, a mixing station is used to adapt the water temperature according to requirements of the floor heating loops. The radiators are directly connected to the unit's water circuit and the floor heating loops and after the mixing station. The mixing station is controlled by the unit.

The domestic water tank, AHS (auxiliary heat source), TBH (water tank electric auxiliary heat), and solar control can be connected. The control method is the same as what is described in the above section.

5.2 Control through the user interface and room thermostat

Space heating or cooling control through the room thermostat needs to be set on the user interface. It can be controlled through mode setting, single-zone control or double-zone control. The monoblock can be connected to a low voltage room thermostat.

5.2.1 Single-zone control

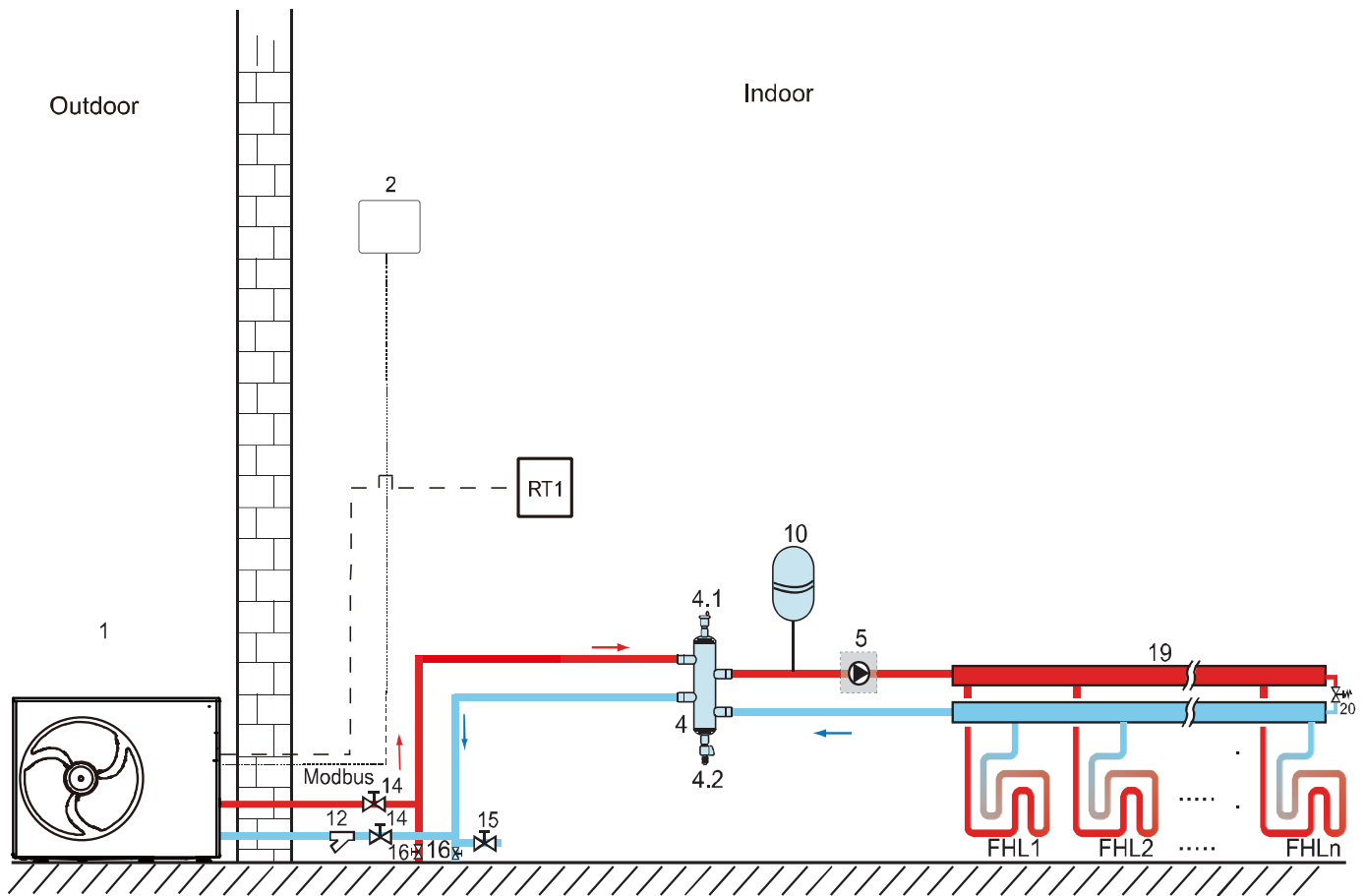

Legend			
1	Main Unit	14	Shut-off valve (Supplied by the user)
2	User interface	15	Filling valve (Supplied by the user)
4	Balance tank (Supplied by the user)	16	Drainage valve (Supplied by the user)
4.1	Automatic air purge valve	19	Collector/distributor (Supplied by the user)
4.2	Drainage valve	20	Bypass valve (Supplied by the user)
5	P_o: Outside circulation pump (Supplied by the user)	RT1	Low voltage room thermostat(Supplied by the user)
10	Expansion vessel (Supplied by the user)	FHL1...n	Floor heating loop (Supplied by the user)
12	Filter (Accessory)		

Notes:

1. The example is just for application illustration; please confirm the exact installation method according to the installation manual.
2. A bypass valve must be installed to make water recirculation possible when all shut-off valves are closed.

Space heating

Single-zone control: the unit ON/OFF is controlled by the room thermostat. The cooling or heating mode and outlet water temperature are set on the user interface. The system is ON when “HT” of the thermostat closes. When “HT” open, the system turns OFF.

Circulation pump operation

When the system turns ON, which means “HT” of the thermostat closes, P_o starts running; When the system turns OFF, which means “HT” open, P_o stops running.

The domestic water tank, AHS (auxiliary heat source), TBH (water tank electric auxiliary heat), and solar control can be connected. The control method is the same as what is described in the above section

5.2.2 Control through mode setting

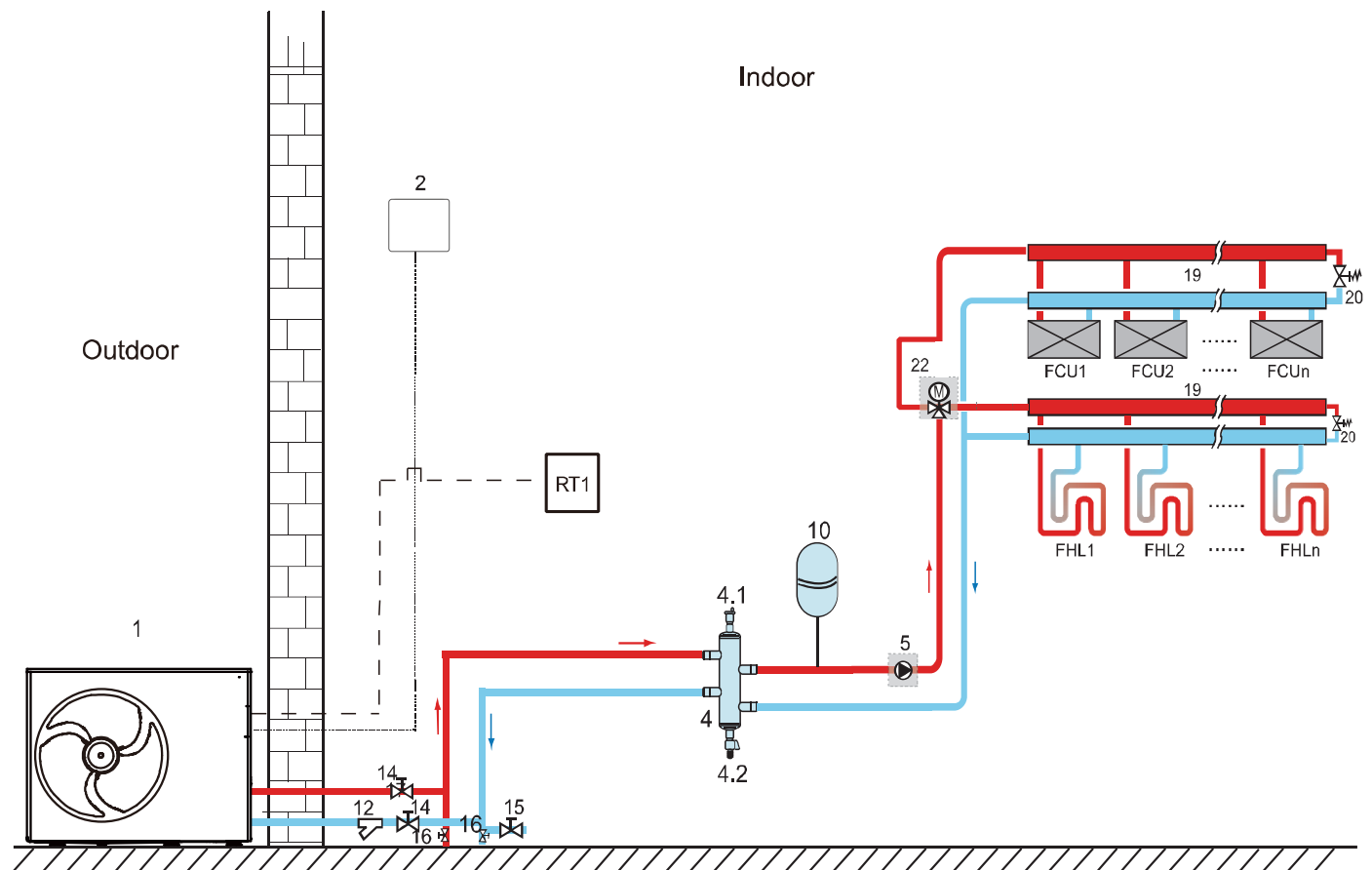

Legend			
1	Main Unit	15	Filling valve (Supplied by the user)
2	User interface	16	Drainage valve (Supplied by the user)
4	Balance tank (Supplied by the user)	19	Collector/distributor (Supplied by the user)
4.1	Automatic air purge valve	20	Bypass valve (Supplied by the user)
4.2	Drainage valve	22	SV2:3-way valve (Supplied by the user)
5	P_o: Outside circulation pump (Supplied by the user)	RT1	Low voltage room thermostat(Supplied by the user)
10	Expansion vessel (Supplied by the user)	FHL1...n	Floor heating loop (Supplied by the user)
12	Filter (Accessory)	FCU1...n	Fan coil unit (Supplied by the user)
14	Shut-off valve (Supplied by the user)		

Notes:

1. The example is just for application illustration; please confirm the exact installation method according to the installation manual.
2. A bypass valve must be installed to make water recirculation possible when all shut-off valves are closed.

Space heating

The cooling or heating mode is set via the room thermostat, and the water temperature is set on the user interface.

- 1) When “CL” of the thermostat closes, the system will be set to work in cooling mode.
- 2) When “HT” of the thermostat closes and all “CL” open, the system will be set to work in heating mode.

Circulation pump operation

- 1) When the system is in cooling mode, which means “CL” of the thermostat closes, SV2 remains OFF while P_o starts running.
- 2) When the system is in heating mode, which means “HT” close and “CL” open, SV2 remains ON while P_o starts running.

The domestic water tank, AHS (auxiliary heat source), TBH (water tank electric auxiliary heat), and solar control can be connected. The control method is the same as what is described in the above section.

5.2.3 Double-zone control

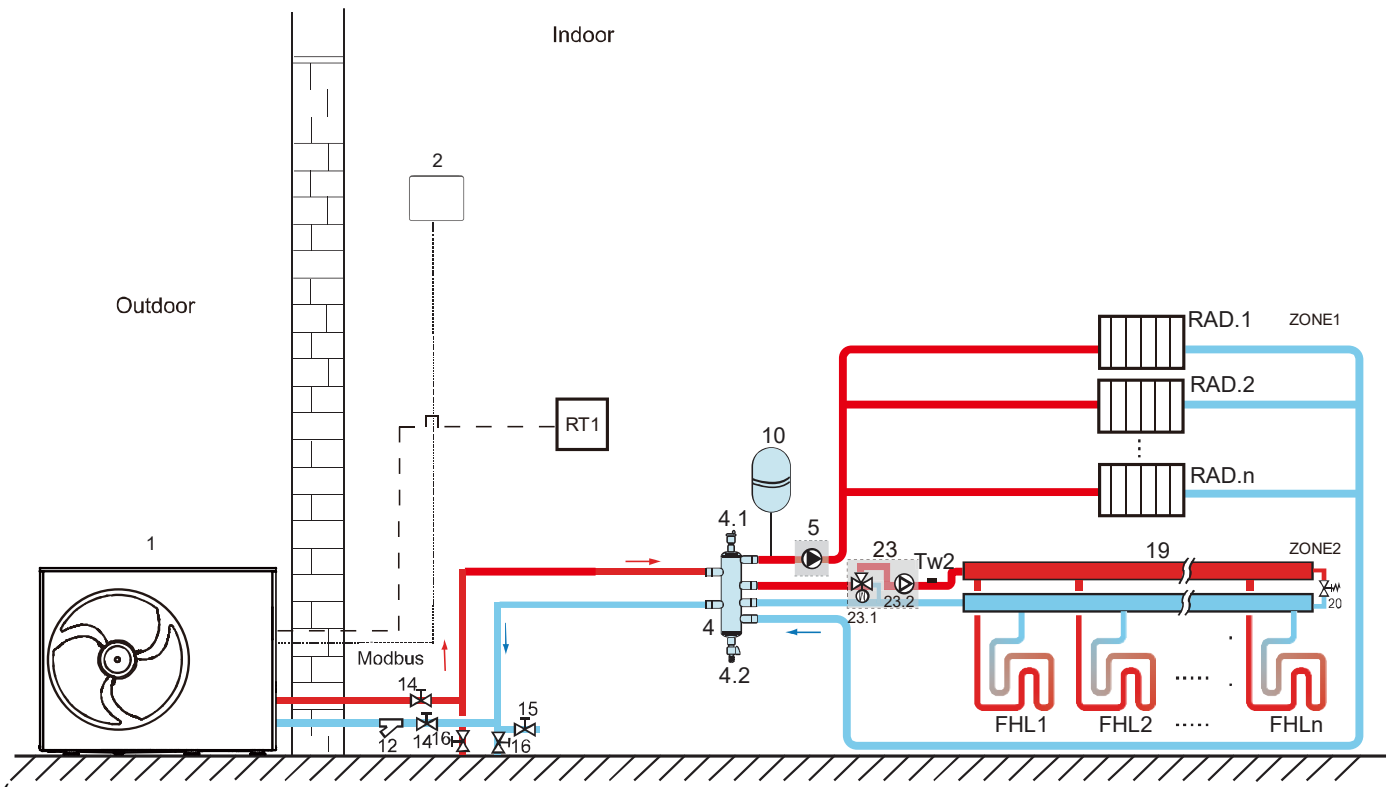

Legend			
1	Main Unit	16	Drainage valve (Supplied by the user)
2	User interface	19	Collector/distributor (Supplied by the user)
4	Balance tank (Supplied by the user)	20	Bypass valve (Supplied by the user)
4.1	Automatic air purge valve	23	Mixing station (Supplied by the user)
4.2	Drainage valve	23.1	SV3: Mixing valve (Supplied by the user)
5	P_o: Zone 1 circulation pump (Supplied by the user)	23.2	P_c: Zone 2 circulation pump (Supplied by the user)
10	Expansion vessel (Supplied by the user)	RT1	Low voltage room thermostat (Supplied by the user)
12	Filter (Accessory)	Tw2	Zone 2 water flow Temperature sensor (Optional)
14	Shut-off valve (Supplied by the user)	FHL1...n	Floor heating loop (Supplied by the user)
15	Filling valve (Supplied by the user)	RAD.1...n	Radiator(Supplied by the user)

Notes:

1. The example is just for application illustration; please confirm the exact installation method according to the installation manual.
2. A bypass valve must be installed to make water recirculation possible when all shut-off valves are closed.

Space heating

Zone1 can operate in cooling mode or heating mode, while Zone 2 can only operate in heating mode; During installation, for thermostat in Zone1, only “HT” terminal need to be connected. For thermostat in Zone2, only “CL” terminals need to be connected.

1) The ON/OFF of Zone1 is controlled by the room thermostat there. When “HT” of thermostat in Zone1 closes, Zone 1 turns ON. When “HT” turn OFF, Zone 1 turns OFF; The target temperature and operation mode are set on the user interface.

2) In heating mode, the ON/OFF of Zone2 is controlled by the room thermostats there. When “CL” of temperature is set on the user interface; Zone 2 can only operate in heating mode. When cooling mode is set on the user interface, Zone2 remains OFF.

Circulation pump operation

When Zone1 turns ON, P_o starts running; When Zone1 turns OFF, P_o stops running;

When Zone2 turns ON, SV3 switches between ON and OFF according to the set Tw2, and P_c remains ON; When Zone 2 Turns OFF, SV3 remains OFF and P_c stops running.

R290 M thermal Nature Plus Series



The floor heating loops require a lower water temperature in heating mode than radiators or fan coil units. To reach the set temperature points, a mixing station is used to adapt the water temperature according to requirements of the floor heating loops. The radiators are directly connected to the unit's water circuit and the floor heating loops and after the mixing station. The mixing station is controlled by the unit.

The domestic water tank, AHS (auxiliary heat source), TBH (water tank electric auxiliary heat), and solar control can be connected. The control method is the same as what is described in the above section.

5.3 Cascade system

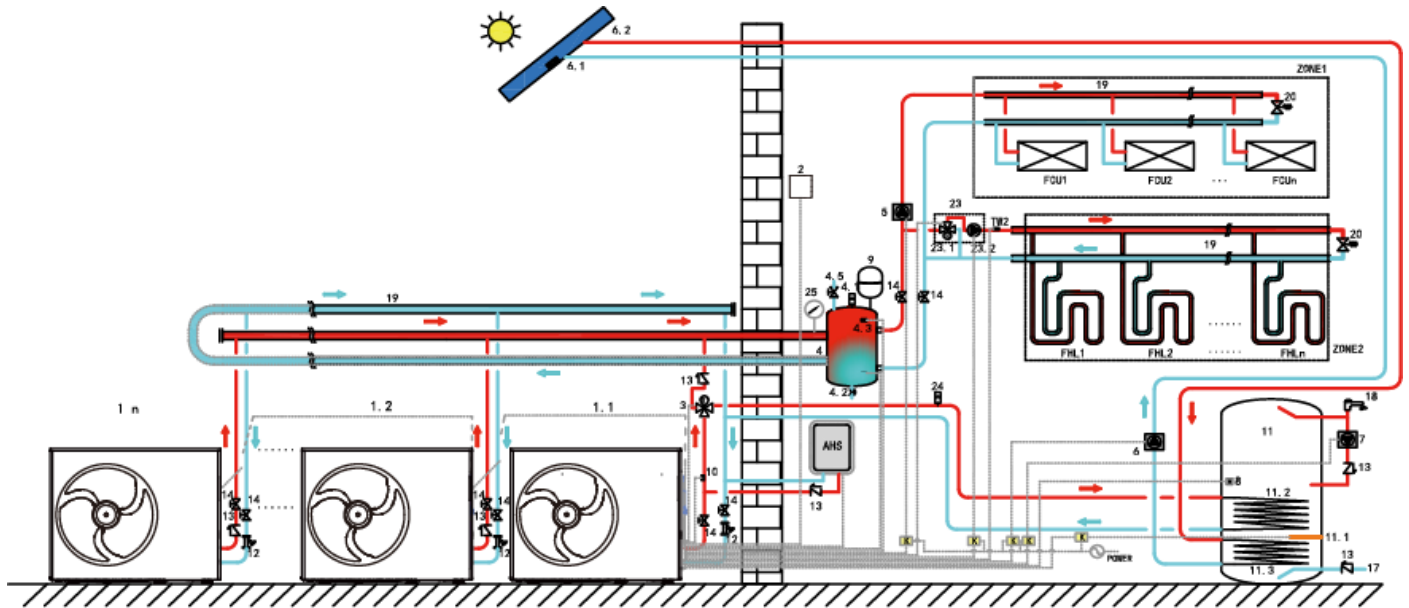

Legend			
1.1	Master Unit	12	Filter (Accessory)
1.2...n	Slave Unit	13	Check valve (Supplied by the user)
2	User interface	14	Shut-off valve (Supplied by the user)
3	SV1:3-way valve (Supplied by the user)	17	Tap water inlet pipe (Supplied by the user)
4	Balance tank (Supplied by the user)	18	Hot water tap (Supplied by the user)
4.1	Automatic air purge valve	19	Collector/distributor (Supplied by the user)
4.2	Drainage valve	20	Bypass valve (Supplied by the user)
4.3	Tbt: temperature sensor of balance tank (Optional)	23	Mixing station
4.5	Filling valve	23.1	SV3: Mixing valve
5	P_o: Outside circulation pump (Supplied by the user)	23.2	P_c: Zone 2 circulation pump (Supplied by the user)
6	P_s: Solar pump (Supplied by the user)	24	Automatic air purge valve(Supplied by the user)
6.1	Tsolar: Solar temperature sensor (Optional)	25	Water manometer (Supplied by the user)
6.2	Solar thermal collector (Supplied by the user)	TW2	Zone 2 water flow temperature sensor (Supplied by the user)
7	P_d: DHW pump (Supplied by the user)	FCU1...n	Fan coil unit (Supplied by the user)
8	T5: Domestic water tank temperature sensor (Accessory)	FHL1...n	Floor heating loop (Supplied by the user)
9	Expansion vessel (Supplied by the user)	K	Contactora (Supplied by the user)
10	T1: Final Water flow temperature sensor (Optional)	ZONE 1	Only heating mode is applicable to the space
11	Domestic hot water tank (Supplied by the user)	ZONE 2	Only heating mode is applicable to the space
11.1	TBH: Domestic hot water tank booster heater (Supplied by the user)	AHS	Auxiliary heat source (Supplied by the user)
11.2	Coil 1, heat exchanger for heat pump		
11.3	Coil 2, heat exchanger for Solar energy		

Notes:

1. The example is just for application illustration; please confirm the exact installation method according to the installation manual.
2. A bypass valve must be installed to make water recirculation possible when all shut-off valves are closed.

Domestic water heating

Only the master unit can operate in DHW mode. T5S is set on the user interface. In DHW mode, SV1 remains ON. When the master unit operates in DHW mode, the slave units can operate in space cooling/heating mode.

Heating mode of slave units

All slave units can operate in space heating mode. The operation mode and temperature are set on the user interface. Due to changes of the outdoor temperature and the required load indoors, multiple outdoor units may operate at different time points.

In cooling mode, SV3 and P_c remains OFF while P_o remains ON.

In heating mode, when both Zone 1 and Zone 2 work, P_c and P_o remain ON, and SV3 switches

R290 M thermal Nature Plus Series

between ON and OFF according to the set TW2.

In heating mode, when only Zone 1 works, P_o remains ON while SV3 and P_c remain OFF.

In heating mode, when only Zone 2 works, P_o remains OFF while P_c remains ON, and SV3 switches between ON and OFF according to the set TW2.

AHS (Auxiliary heat source) control

The AHS should be set via For serviceman mode on the user interface. The AHS is only controlled by the master unit. When the master unit operates in DHW mode, the AHS can only be used for producing domestic hot water; When the master unit operates in heating mode, the AHS can only operate in heating mode.

1) When the AHS is set to be valid only in heating mode, it will be turned on in the following conditions:

- a. The BACKUP HEATER function is enabled on user interface;
- b. The master unit operates in heating mode. When the inlet water temperature or ambient temperature is too low while the target leaving water temperature is too high, the AHS will be turned on automatically.

2) When the AHS is set to be valid in heating mode and DHW mode, it will be turned on in following conditions:

When the master unit operates in heating mode, conditions for turning on the AHS is same as 1); When the master unit operates in DHW mode, if T5 or the ambient temperature is too low while the target T5 temperature is too high, the AHS will be turned on automatically.

3) When the AHS is valid, the operation of the AHS is controlled by M1M2. When M1M2 closes, the AHS is turned on.

When the master unit operates in DHW mode, the AHS can not be turned on by closing M1 M2.

TBH (Tank booster heater) control

The TBH should be set via For serviceman mode on the user interface. The TBH is only controlled by the master unit.

Solar energy control

Solar energy is only controlled by the master unit.

Part 2

Engineering Data

1 Specifications.....	20
2 Electrical Characteristics.....	24
3 3-Dimensional Drawings And Center Of Gravity.....	25
4 Operating Limits	26
5 Hydronic Performance	28
6 Capacity Tables	29

1 Specifications

1.1 Single Phase 8-16 kW

Table 2-1.1: Single phase 8-16kW specifications

R290 Nature Plus Series			MHC-V8WD2N7-B2	MHC-V10WD2N7-B2	MHC-V12WD2N7-B2	MHC-V14WD2N7-B2	MHC-V16WD2N7-B2
Power supply	V/Ph/Hz		220-240/1/50				
Heating A7W35	Capacity	W	8000	9500	12100	14000	15500
	Rated input	W	1524	1919	2444	2979	3444
	COP	/	5.25	4.95	4.95	4.70	4.50
Heating A7W45	Capacity	W	8100	9500	12300	14100	15500
	Rated input	W	2025	2436	3154	3760	4247
	COP	/	4.00	3.90	3.90	3.75	3.65
Heating A7W55	Capacity	W	8000	9500	11900	13800	16000
	Rated input	W	2388	2969	3662	4381	5246
	COP	/	3.35	3.20	3.25	3.15	3.05
Heating A2W35	Capacity	W	7100	8200	9200	11000	13000
	Rated input	W	1732	2103	2300	2895	3714
	COP	/	4.10	3.90	4.00	3.80	3.50
Heating A2W45	Capacity	W	8000	9000	11500	12500	13800
	Rated input	W	2540	2951	3710	4098	4759
	COP	/	3.15	3.05	3.10	3.05	2.90
Heating A2W55	Capacity	W	8000	9000	11500	12500	13800
	Rated input	W	2963	3529	4340	4808	5520
	COP	/	2.70	2.55	2.65	2.60	2.50
Heating A-7W35	Capacity	W	7000	8000	10000	12000	13100
	Rated input	W	2154	2540	3175	4286	4852
	COP	/	3.25	3.15	3.15	2.80	2.70
Heating A-7W45	Capacity	W	8000	9000	11000	12000	13000
	Rated input	W	3077	3600	4400	5000	5652
	COP	/	2.60	2.50	2.50	2.40	2.30
Heating A-7W55	Capacity	W	7500	8800	11000	12000	13000
	Rated input	W	3261	4000	4889	5581	6190
	COP	/	2.30	2.20	2.25	2.15	2.10
Cooling A35W18	Capacity	W	8300	10000	12000	14000	15000
	Rated input	W	1581	2174	2609	3182	3529
	EER	/	5.25	4.60	4.60	4.40	4.25
Cooling A35W7	Capacity	W	7450	8100	11500	12400	14000
	Rated input	W	2224	2613	3770	4133	5185
	EER	/	3.35	3.10	3.05	3.00	2.70
Seasonal space heating energy efficiency class	LWT at 35°C		A+++				
	LWT at 55°C		A+++				
SEER	LWT at 7°C		5.61	5.53	4.99	4.97	4.98
	LWT at 18°C		7.63	7.67	7.03	6.94	6.87

Table continued on next page...

Table 2- 1.1: Single phase 8-16kW specifications (continued)

R290 Nature Plus Series			MHC-V8WD2N7-B2	MHC-V10WD2N7-B2	MHC-V12WD2N7-B2	MHC-V14WD2N7-B2	MHC-V16WD2N7-B2
SCOP	Warmer climate	35°C	6.91	6.87	6.8	6.74	6.77
		55°C	4.86	4.85	4.89	4.87	4.86
	Average climate	35°C	5.35	5.33	4.94	4.76	4.72
		55°C	4.06	4.01	3.96	3.85	3.86
	Colder climate	35°C	4.6	4.53	4.53	4.45	4.31
		55°C	3.45	3.49	3.56	3.54	3.51
Erp Sound power level		dB	53	54	55	57	59
Sound power level	Heating A7W35	dB	52	54	54	57	58
	Heating Max.	dB	57	58	61	62	63
	Heating Silent mode 1	dB	51	53	56	57	59
	Heating Silent mode 2	dB	49	51	54	54	55
	Cooling A35W18	dB	53	54	56	57	59
	Cooling max	dB	56	57	60	61	62
	Cooling Silent mode 1	dB	53	54	54	55	56
	Cooling Silent mode 2	dB	51	52	52	53	54
Sound pressure level (1m)	Heating A7W35	dB(A)	40	41	43	46	49
	Cooling A35W18	dB(A)	39	41	42	43	44
Sound pressure level (2m)	Heating A7W35	dB(A)	37	38	40	42	44
	Cooling A35W18	dB(A)	35	37	38	39	42
Water flow range		m ³ /h	0.40 - 1.65	0.40 - 2.10	0.70 - 2.50	0.70 - 2.75	0.70 - 3.00
Compressor	Type		Twin rotary				
Outdoor fan	Motor type / Number of fans		DC fan / 1				
Air-side heat exchanger		Finned tube heat exchanger					
Refrigerant	Type/ Charged volume		R290/1100g		R290/1500g		
Unit dimensions (H×W×D)		mm	1051×1330×475				
Packing dimensions (H×W×D)		mm	1235×1390×570				
Net weight		kg	148		169		
Gross weight		kg	170		191		
Backup electric heater weight (optional)		kg	5				
Water-side heat exchanger		Plate heat exchanger					
Water-side Connection dimensions		G1 1/4"BSP					
Water pump	Max. pump head	m	9				
Safety valve		Mpa	0.3				
Flow switch		m ³ /h	0.36		0.6		
Outdoor air temperature range	Cooling	°C	-5~46				
	Heating	°C	-25~35				
	DHW	°C	-25~46				
Water setting temperature range	Cooling	°C	5~25				
	Heating	°C	25~80				
	DHW	°C	20~70				

Notes:

The above data test reference standard EN14511; EN14825; EN50564; EN 12102; (EU) No:811

R290 M thermal Nature Plus Series



1.2 Three Phase, 8-16 kW

Table 2-1.2: Three phase 8-16kW specifications

R290 Nature Plus Series			MHC-V8WD2RN7-B2	MHC-V10WD2RN7-B2	MHC-V12WD2RN7-B2	MHC-V14WD2RN7-B2	MHC-V16WD2RN7-B2
Power supply	V/Ph/Hz		380-415/3/50				
Heating A7W35	Capacity	W	8000	9500	12100	14000	15500
	Rated input	W	1524	1919	2444	2979	3444
	COP	/	5.25	4.95	4.95	4.70	4.50
Heating A7W45	Capacity	W	8100	9500	12300	14100	15500
	Rated input	W	2025	2436	3154	3760	4247
	COP	/	4.00	3.90	3.90	3.75	3.65
Heating A7W55	Capacity	W	8000	9500	11900	13800	16000
	Rated input	W	2388	2969	3662	4381	5246
	COP	/	3.35	3.20	3.25	3.15	3.05
Heating A2W35	Capacity	W	7100	8200	9200	11000	13000
	Rated input	W	1732	2103	2300	2895	3714
	COP	/	4.10	3.90	4.00	3.80	3.50
Heating A2W45	Capacity	W	8000	9000	11500	12500	13800
	Rated input	W	2540	2951	3710	4098	4759
	COP	/	3.15	3.05	3.10	3.05	2.90
Heating A2W55	Capacity	W	8000	9000	11500	12500	13800
	Rated input	W	2963	3529	4340	4808	5520
	COP	/	2.70	2.55	2.65	2.60	2.50
Heating A-7W35	Capacity	W	7000	8000	10000	12000	13100
	Rated input	W	2154	2540	3175	4286	4852
	COP	/	3.25	3.15	3.15	2.80	2.70
Heating A-7W45	Capacity	W	8000	9000	11000	12000	13000
	Rated input	W	3077	3600	4400	5000	5652
	COP	/	2.60	2.50	2.50	2.40	2.30
Heating A-7W55	Capacity	W	7500	8800	11000	12000	13000
	Rated input	W	3261	4000	4889	5581	6190
	COP	/	2.30	2.20	2.25	2.15	2.10
Cooling A35W18	Capacity	W	8300	10000	12000	14000	15000
	Rated input	W	1581	2174	2609	3182	3529
	EER	/	5.25	4.60	4.60	4.40	4.25
Cooling A35W7	Capacity	W	7450	8100	11500	12400	14000
	Rated input	W	2224	2613	3770	4133	5185
	EER	/	3.35	3.10	3.05	3.00	2.70
Seasonal space heating energy efficiency class	LWT at 35°C		A+++				
	LWT at 55°C		A+++				
SEER	LWT at 7°C		5.61	5.53	4.99	4.97	4.98
	LWT at 18°C		7.63	7.67	7.03	6.94	6.87

Table continued on next page...

Table 2-1.2: Three phase 8-16kW specifications (continued)

R290 Nature Plus Series			MHC-V8WD2RN7-B2	MHC-V10WD2RN7-B2	MHC-V12WD2RN7-B2	MHC-V14WD2RN7-B2	MHC-V16WD2RN7-B2
SCOP	Warmer climate	35°C	6.91	6.87	6.8	6.74	6.77
		55°C	4.86	4.85	4.89	4.87	4.86
	Average climate	35°C	5.35	5.33	4.94	4.76	4.72
		55°C	4.06	4.01	3.96	3.85	3.86
	Colder climate	35°C	4.6	4.53	4.53	4.45	4.31
		55°C	3.45	3.49	3.56	3.54	3.51
Erp Sound power level		dB	53	54	55	57	59
Sound power level	Heating A7W35	dB	52	54	54	57	58
	Heating Max.	dB	57	58	61	62	63
	Heating Silent mode1	dB	51	53	56	57	59
	Heating Silent mode2	dB	49	51	54	54	55
	Cooling A35W18	dB	53	54	56	57	59
	Cooling max	dB	56	57	60	61	62
	Cooling Silent mode1	dB	53	54	54	55	56
	Cooling Silent mode2	dB	51	52	52	53	54
Sound pressure level (1m)	Heating A7W35	dB(A)	40	41	43	46	49
	Cooling A35W18	dB(A)	39	41	42	43	44
Sound pressure level (2m)	Heating A7W35	dB(A)	37	38	40	42	44
	Cooling A35W18	dB(A)	35	37	38	39	42
Water flow range		m ³ /h	0.40 - 1.65	0.40 - 2.10	0.70 - 2.50	0.70 - 2.75	0.70 - 3.00
Compressor	Type		Twin rotary				
Outdoor fan	Motor type / Number of fans		DC fan / 1				
Air-side heat exchanger		Finned tube heat exchanger					
Refrigerant	Type/ Charged volume		R290/1100g		R290/1500g		
Unit dimensions (H×W×D)		mm	1051×1330×475				
Packing dimensions (H×W×D)		mm	1235×1390×570				
Net weight		kg	153		169		
Gross weight		kg	175		191		
Backup electric heater weight (optional)		kg	5				
Water-side heat exchanger		Plate heat exchanger					
Water-side Connection dimensions		G1 1/4" BSP					
Water pump	Max. pump head	m	9				
Safety valve		Mpa	0.3				
Flow switch		m ³ /h	0.36		0.6		
Outdoor air temperature range	Cooling	°C	-5~46				
	Heating	°C	-25~35				
	DHW	°C	-25~46				
Water setting temperature range	Cooling	°C	5~25				
	Heating	°C	25~80				
	DHW	°C	20~70				

Notes:

The above data test reference standard EN14511; EN14825; EN50564; EN 12102; (EU) No:811

1.3 E-heater parameters

Table 2-1.3: E-heater parameters

Backup electric heater capacity	Power supply	Min.(V)	Max.(V)	MCA(A)	TOCA(A)	MFA(A)
3kW	220-240/1/50	198	264	13.5	13.5	16
6kW	380-415/3/50	342	456	9	9	16
9kW	380-415/3/50	342	456	13.5	13.5	16

2 Electrical characteristics

Table 2-1.4: 2 Electrical characteristics

System	Outdoor unit			Power current		
	Power supply	Min. (V)	Max. (V)	MCA (A)	TOCA (A)	MFA (A)
MHC-V8WD2N7-B2	220~240/1N/50Hz	198	264	18	19.5	20
MHC-V10WD2N7-B2	220~240/1N/50Hz	198	264	19.5	21	25
MHC-V12WD2N7-B2	220~240/1N/50Hz	198	264	26	31	32
MHC-V14WD2N7-B2	220~240/1N/50Hz	198	264	27.5	31	32
MHC-V16WD2N7-B2	220~240/1N/50Hz	198	264	29.5	31	32
MHC-V8WD2RN7-B2	380~415/3N/50Hz	342	456	6	8	10
MHC-V10WD2RN7-B2	380~415/3N/50Hz	342	456	6.5	8	10
MHC-V12WD2RN7-B2	380~415/3N/50Hz	342	456	9	11	16
MHC-V14WD2RN7-B2	380~415/3N/50Hz	342	456	9.5	11	16
MHC-V16WD2RN7-B2	380~415/3N/50Hz	342	456	10	11	16

Notes:

Name	Description	Explanation
Min. & Max.	Minimum & Maximum running voltage (V)	Required voltage range for system operation
MCA	Min. Circuit Amps. (A)	Determines the minimum wire diameter
TOCA	Total Over-current Amps. (A)	The maximum current for system protection
MFA	Max. Fuse Amps. (A)	Determines air-break switch /circuit breaker/ Fuse

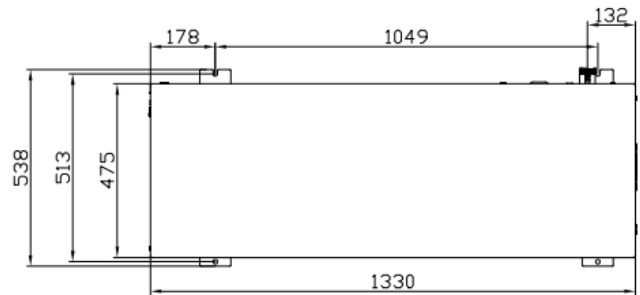
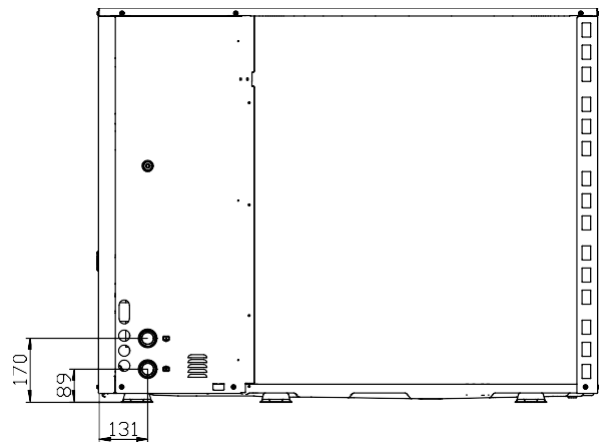
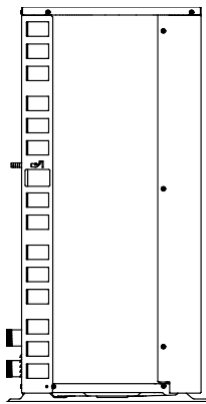
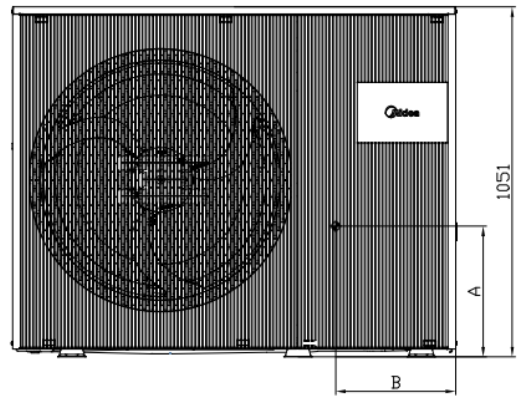
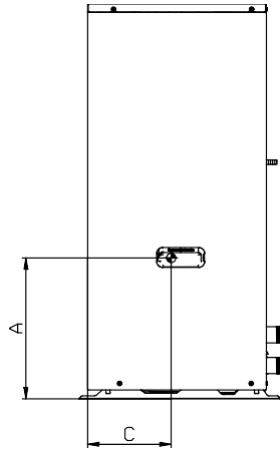
3 3-dimensional drawings and Center of Gravity

Unit: mm

Model	A	B	C
1 phase 8/10kW	415	490	205
3phase 8/10kW	356	490	197
1 phase 12/14/16kW	347	535	225
3 phase 12/14/16kW			

4 Operating Limits

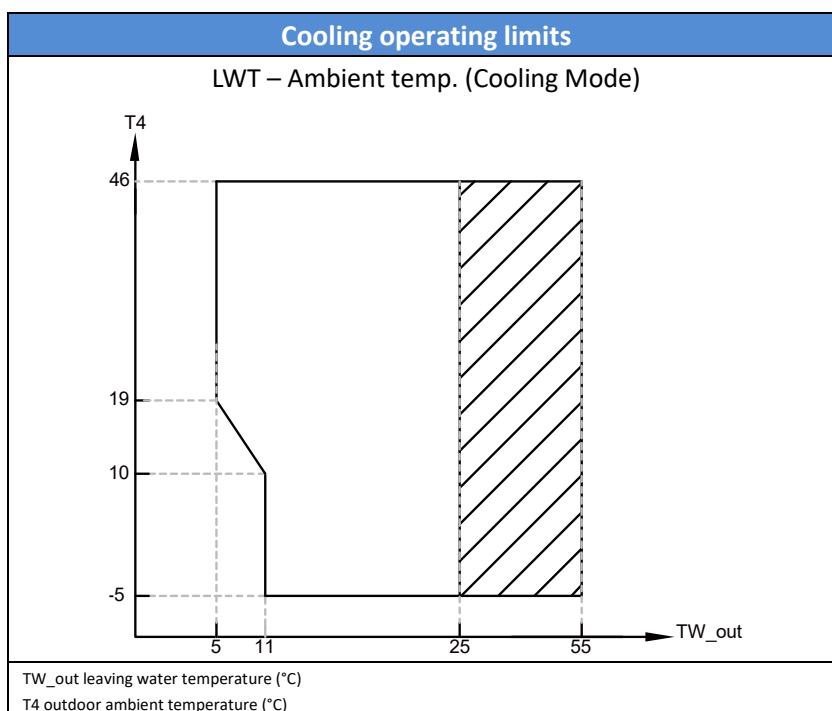
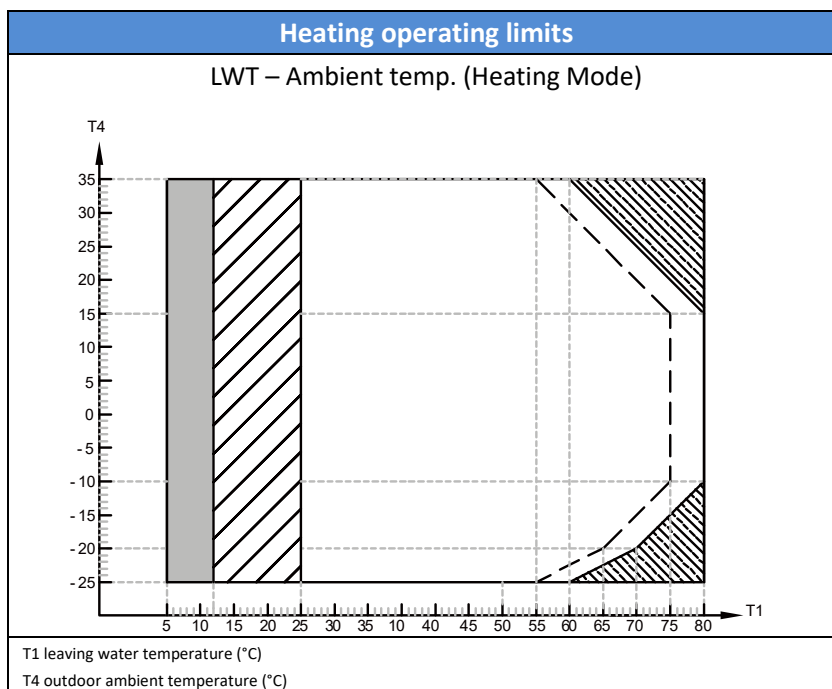

- Notes:
1. If IBH/AHS setting is activated, only IBH/AHS turns on; If IBH/AHS setting is not activated, only heat pump turns on. Limitation and protection may occur during heat pump operation.
 2. Heat pump operating range with possible limitation and protection.
 3. Heat pump turns off, only IBH/AHS on.
 4. Maximum inlet water temperature line for heat pump operation.

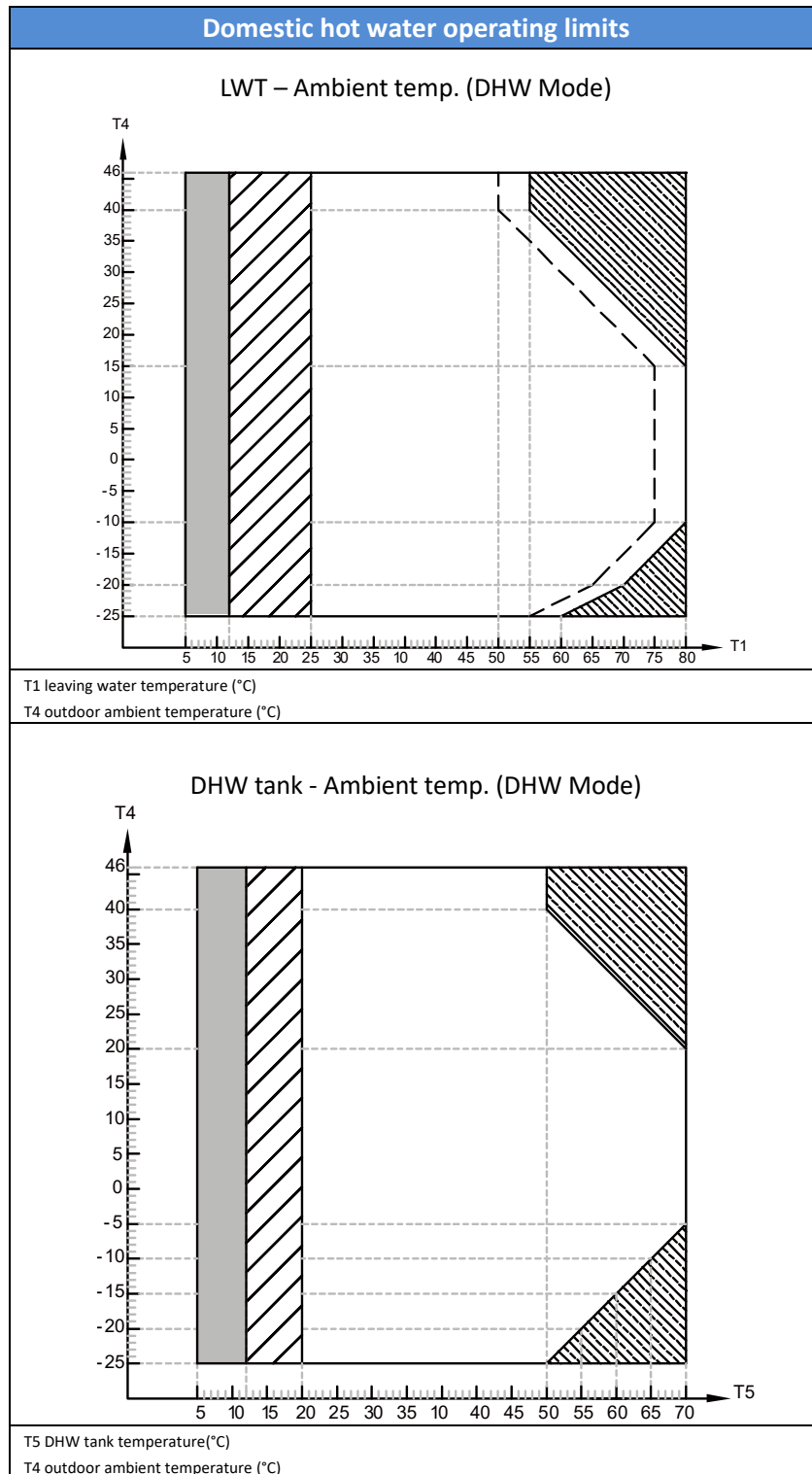

Notes:

1. If IBH/AHS setting is activated, only IBH/AHS turns on; If IBH/AHS setting is not activated, only heat pump turns on. Limitation and protection may occur during heat pump operation.
2. Heat pump operating range with possible limitation and protection.
3. Heat pump turns off, only IBH/AHS on.
4. — —Maximum inlet water temperature line for heat pump operation.

5 Hydronic Performance

8-10kW hydronic performance

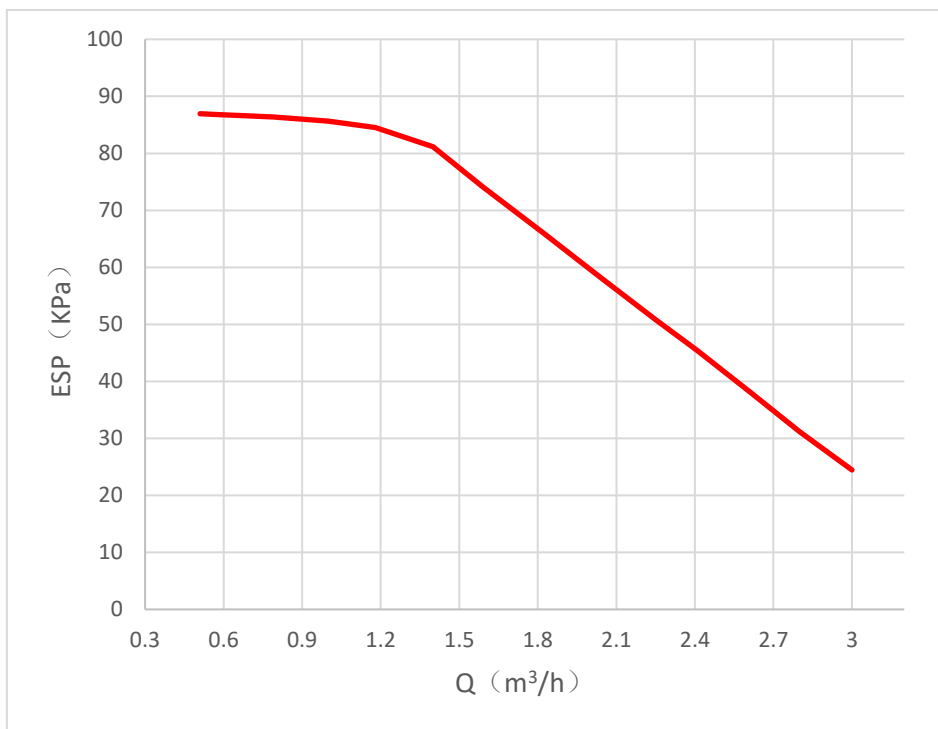

Abbreviations:
ESP: External static pressure

12-16kW hydronic performance

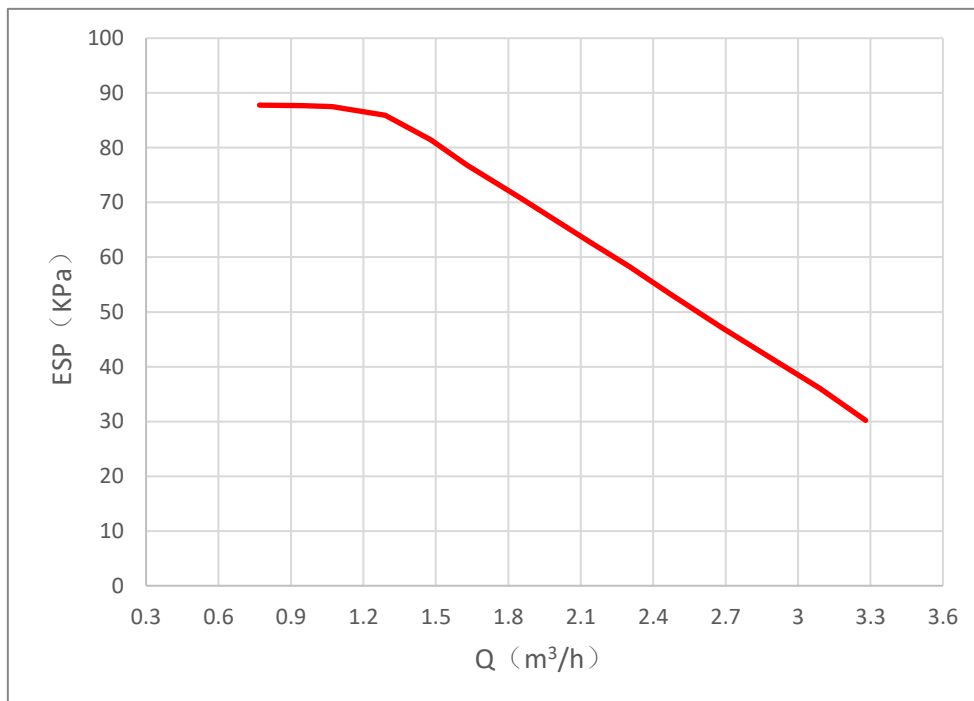

Abbreviations:
ESP: External static pressure

6 Capacity Tables

6.1 Heating Capacity Tables (Test standard: EN14511)

Table 2-6.1: 8kW heating capacity

LWT	DB	Maximum			100% (Normal)			75%			50%			25%			Minimum		
		HC	COP	PI	HC	COP	PI	HC	COP	PI	HC	COP	PI	HC	COP	PI	HC	COP	PI
25	-25	5.66	2.20	2.57	5.66	2.20	2.57	5.37	2.23	2.41	3.49	2.51	1.39	1.97	3.00	0.66	1.97	3.00	0.66
	-20	6.96	2.42	2.88	6.96	2.42	2.88	5.33	2.69	1.98	3.44	2.82	1.22	2.45	3.25	0.75	2.45	3.25	0.75
	-15	8.08	2.78	2.91	7.13	2.98	2.39	5.41	3.20	1.69	3.57	3.60	0.99	2.94	3.78	0.78	2.94	3.78	0.78
	-10	9.24	3.14	2.94	7.00	3.69	1.90	5.19	4.05	1.28	3.52	4.30	0.82	3.32	4.38	0.76	3.32	4.38	0.76
	-7	9.79	3.53	2.77	7.03	3.99	1.76	5.22	4.31	1.21	3.58	4.70	0.76	3.58	4.70	0.76	3.58	4.70	0.76
	-5	10.26	3.65	2.81	7.03	4.25	1.65	5.24	4.61	1.14	3.67	4.91	0.75	3.67	4.91	0.75	3.67	4.91	0.75
	-2	10.93	3.98	2.75	7.06	4.68	1.51	5.25	5.21	1.01	4.03	5.47	0.74	3.70	5.50	0.67	3.70	5.50	0.67
	0	11.16	4.13	2.70	7.09	5.02	1.41	5.31	5.36	0.99	4.01	5.69	0.70	3.94	5.88	0.67	3.94	5.88	0.67
	2	11.52	4.50	2.56	7.17	5.38	1.33	5.33	5.63	0.95	4.28	5.98	0.72	4.18	6.20	0.67	4.18	6.20	0.67
	5	11.75	5.60	2.10	7.56	6.24	1.21	5.73	6.64	0.86	4.36	6.90	0.63	3.85	7.00	0.55	3.85	7.00	0.55
	7	12.03	6.05	1.99	7.93	6.90	1.15	5.98	7.23	0.83	4.65	7.61	0.61	3.99	7.50	0.53	3.99	7.50	0.53
	10	12.30	6.95	1.77	7.98	7.78	1.03	6.08	8.27	0.74	5.12	8.50	0.60	4.20	7.90	0.53	4.20	7.90	0.53
	12	12.57	7.61	1.65	8.08	8.30	0.97	5.97	8.85	0.67	5.48	9.06	0.60	4.55	8.80	0.52	4.55	8.80	0.52
	15	11.14	8.25	1.35	8.01	9.06	0.88	6.01	9.40	0.64	4.88	9.58	0.51	4.65	9.10	0.51	4.65	9.10	0.51
	20	10.47	9.36	1.12	7.98	9.97	0.80	5.93	10.23	0.58	4.82	10.41	0.46	4.82	9.56	0.50	4.82	9.56	0.50
	25	10.88	10.10	1.08	8.07	10.92	0.74	5.95	11.35	0.52	5.01	11.52	0.43	5.01	11.05	0.45	5.01	11.05	0.45
30	/	/	/	/	/	/	/	/	/	/	/	/	/	/	/	/	/	/	/
35	/	/	/	/	/	/	/	/	/	/	/	/	/	/	/	/	/	/	/
30	-25	5.61	2.07	2.71	5.61	2.07	2.71	5.30	2.10	2.52	3.56	2.36	1.51	1.89	2.70	0.70	1.89	2.70	0.70
	-20	6.91	2.30	3.00	6.91	2.30	3.00	5.33	2.58	2.07	3.49	2.70	1.29	2.37	3.10	0.76	2.37	3.10	0.76
	-15	7.92	2.62	3.02	7.20	2.71	2.66	5.47	3.02	1.81	3.54	3.38	1.05	2.86	3.58	0.80	2.86	3.58	0.80
	-10	9.08	2.91	3.12	6.93	3.35	2.07	5.18	3.71	1.40	3.42	3.92	0.87	3.42	3.92	0.87	3.42	3.92	0.87
	-7	9.64	3.20	3.01	7.00	3.60	1.94	5.20	3.98	1.31	3.80	4.18	0.91	3.80	4.18	0.91	3.80	4.18	0.91
	-5	10.14	3.38	3.00	7.02	3.88	1.81	5.23	4.26	1.23	3.91	4.50	0.87	3.91	4.50	0.87	3.91	4.50	0.87
	-2	10.80	3.70	2.92	7.09	4.31	1.65	5.25	4.73	1.11	4.02	4.99	0.81	3.64	5.01	0.73	3.64	5.01	0.73
	0	11.00	3.84	2.86	7.11	4.50	1.58	5.29	4.91	1.08	4.05	5.18	0.78	3.88	5.30	0.73	3.88	5.30	0.73
	2	11.36	4.08	2.78	7.15	4.83	1.48	5.33	5.11	1.04	4.19	5.45	0.77	3.94	5.43	0.73	3.94	5.43	0.73
	5	11.57	4.58	2.53	7.65	5.31	1.44	5.74	5.78	0.99	4.26	6.11	0.70	3.78	6.30	0.60	3.78	6.30	0.60
	7	11.82	5.15	2.30	7.90	5.98	1.32	6.00	6.41	0.94	4.55	6.67	0.68	3.95	6.85	0.58	3.95	6.85	0.58
	10	12.11	5.97	2.03	8.08	6.71	1.20	5.96	7.16	0.83	5.03	7.35	0.68	4.06	7.60	0.53	4.06	7.60	0.53
	12	12.35	6.35	1.94	7.90	7.12	1.11	6.07	7.49	0.81	5.38	7.62	0.71	4.37	8.10	0.54	4.37	8.10	0.54
	15	10.95	6.92	1.58	8.05	7.48	1.08	6.10	7.84	0.78	4.78	8.20	0.58	4.48	8.27	0.54	4.48	8.27	0.54
	20	10.33	8.07	1.28	8.07	8.60	0.94	6.02	8.82	0.68	4.71	9.16	0.51	4.55	8.63	0.53	4.55	8.63	0.53
	25	10.70	9.15	1.17	7.94	9.72	0.82	6.10	10.10	0.60	4.94	10.35	0.48	4.80	9.01	0.53	4.80	9.01	0.53
30	11.15	10.26	1.09	7.96	10.90	0.73	6.04	11.50	0.53	5.43	11.63	0.47	5.18	9.52	0.54	5.18	9.52	0.54	
35	/	/	/	/	/	/	/	/	/	/	/	/	/	/	/	/	/	/	/
35	-25	5.55	1.96	2.83	5.55	1.96	2.83	5.31	2.01	2.64	3.58	2.16	1.66	1.82	2.38	0.76	1.82	2.38	0.76
	-20	6.86	2.21	3.10	6.86	2.21	3.10	5.38	2.42	2.22	3.49	2.56	1.36	2.28	2.72	0.84	2.28	2.72	0.84
	-15	7.85	2.49	3.15	7.11	2.54	2.80	5.41	2.74	1.97	3.52	2.98	1.18	2.76	3.06	0.90	2.76	3.06	0.90
	-10	8.96	2.72	3.29	7.01	3.13	2.24	5.15	3.26	1.58	3.43	3.34	1.03	3.31	3.36	0.99	3.31	3.36	0.99
	-7	9.12	2.75	3.32	7.00	3.25	2.15	5.18	3.53	1.47	3.78	3.67	1.03	3.78	3.67	1.03	3.78	3.67	1.03
	-5	9.96	3.16	3.15	7.02	3.54	1.98	5.20	3.88	1.34	4.07	4.00	1.02	4.07	4.00	1.02	4.07	4.00	1.02
	-2	10.70	3.50	3.06	7.04	3.95	1.78	5.24	4.31	1.22	4.07	4.42	0.92	3.54	4.35	0.81	3.54	4.35	0.81
	0	10.83	3.60	3.01	7.08	4.08	1.74	5.28	4.41	1.20	4.05	4.66	0.87	3.77	4.55	0.83	3.77	4.55	0.83
	2	11.20	3.78	2.96	7.10	4.10	1.73	5.35	4.54	1.18	4.08	4.75	0.86	3.89	4.75	0.82	3.89	4.75	0.82
	5	11.37	4.12	2.76	7.60	4.76	1.60	5.72	5.20	1.10	4.36	5.36	0.81	3.64	5.40	0.67	3.64	5.40	0.67
	7	11.61	4.53	2.56	8.00	5.25	1.52	6.01	5.66	1.06	4.65	5.93	0.78	3.71	5.65	0.66	3.71	5.65	0.66
	10	11.87	5.21	2.28	8.04	5.94	1.35	5.97	6.32	0.94	4.96	6.58	0.75	3.99	5.79	0.69	3.99	5.79	0.69
	12	12.12	5.70	2.13	8.00	6.32	1.27	5.91	6.75	0.88	5.05	6.90	0.73	4.40	6.95	0.63	4.40	6.95	0.63
	15	10.73	6.11	1.76	8.00	6.81	1.17	5.97	7.22	0.83	4.77	7.57	0.63	4.50	7.30	0.62	4.50	7.30	0.62
	20	10.14	7.04	1.44	8.11	7.61	1.07	5.90	8.05	0.73	4.68	8.41	0.56	4.70	8.00	0.59	4.70	8.00	0.59
	25	10.50	7.98	1.32	8.00	8.63	0.93	5.97	9.10	0.66	4.81	9.39	0.51	5.00	8.47	0.59	5.00	8.47	0.59
30	10.93	9.08	1.20	8.04	9.87	0.81	6.13	10.29	0.60	5.30	10.71	0.49	5.20	9.02	0.58	5.20	9.02	0.58	
35	11.25	10.10	1.11	8.02	11.08	0.72	6.05	11.75	0.51	5.83	11.92	0.49	5.60	9.35	0.60	5.60	9.35	0.60	
40	-25	5.53	1.87	2.96	5.53	1.87	2.96	5.53	1.87	2.96	3.71	1.94	1.91	1.81	2.06	0.88	1.81	2.06	0.88
	-20	6.78	2.16	3.14	6.78	2.16	3.14	5.76	2.28	2.53	3.68	2.40	1.53	2.35	2.48	0.95	2.35	2.48	0.95
	-15	7.81	2.24	3.49	7.44	2.26	3.29	5.78	2.39	2.42	3.73	2.62	1.42	2.82	2.81	1.00	2.82	2.81	1.00
	-10	8.82	2.54	3.47	7.45	2.77	2.69	5.61	2.95	1.90	3.69	3.11	1.19	3.39	3.17	1.07	3.39	3.17	1.07
	-7	9.37	2.77	3.38	7.49	3.05	2.46	5.64	3.30	1.71	3.86	3.45	1.12	3.86	3.45	1.12	3.86	3.45	1.12
	-5	9.87	2.92	3.38	7.52	3.26	2.31	5.60	3.48	1.61	4.17	3.63	1.15	4.17	3.63	1.15	4.17	3.63	1.15
	-2	10.65	3.15	3.38	7.59	3.31	2.29	5.64	3.66	1.54	4.19	3.80	1.10	3.50	3.85	0.91	3.50	3.85	0.91
	0	10.73	3.28	3.27	7.63	3.44	2.22	5.56	3.80	1.46	4.39	3.92	1.12	3.72	4.00	0.93	3.72	4.00	0.93
	2	11.12	3.58	3.11	7.68	3.67	2.09	5.69	3.91	1.46	4.71	4.18	1.13	3.82	4.25	0.90	3.82	4.25	0.90
	5	11.21	3.80	2.95	7.76	4.26	1.82	5.85	4.65	1.26	4.89	4.86	1.01	3.37	4.44	0.76	3.37	4.44	0.76
	7	11.44	4.10	2.79	8.08	4.78	1.69	6.00	5.12	1.17	5.23	5.30	0.99	3.49	4.65	0.75	3.49	4.65	0.75
	10	11.68	4.55	2.57	8.01	5.20	1.54	5.97	5.58	1.07	5.43	5.79	0.94	3.75	4.82	0.78	3.75	4.82	0.78
	12	11.92	4.94	2.41	7.98	5.66	1.41	6.08	6.00	1.01	5.62	6.25	0.90	4.04	5.45	0.74	4.04	5.45	0.74
	15	10.53	5.38	1.96	7.92	6.08	1.30	6.01	6.51	0.92	5.62	6.70	0.84	4.18	5.71	0.73	4.18	5.71	0.73
	20	9.92	6.21	1.60	8.15	6.67	1.22	5.95	7.18	0.83	5.13	7.46	0.69	4.53	6.18	0.73	4.53	6.18	0.73</

R290 M thermal Nature Plus Series



Table 2-6.1: 8kW heating capacity (continued)

LWT	DB	Maximum			100% (Normal)			75%			50%			25%			Minimum		
		HC	COP	PI	HC	COP	PI	HC	COP	PI	HC	COP	PI	HC	COP	PI	HC	COP	PI
45	-25	5.48	1.77	3.10	5.48	1.77	3.10	5.48	1.77	3.10	3.99	1.85	2.16	2.11	1.96	1.08	2.11	1.96	1.08
	-20	6.65	2.12	3.14	6.65	2.12	3.14	6.09	2.14	2.85	4.02	2.25	1.79	2.68	2.31	1.16	2.68	2.31	1.16
	-15	7.72	2.22	3.48	7.72	2.22	3.48	6.15	2.36	2.61	4.03	2.48	1.63	3.19	2.52	1.27	3.19	2.52	1.27
	-10	8.60	2.42	3.55	7.97	2.48	3.21	5.95	2.60	2.29	4.05	2.70	1.50	3.80	2.72	1.40	3.80	2.72	1.40
	-7	9.29	2.46	3.78	8.00	2.60	3.08	6.00	2.72	2.21	4.30	2.91	1.48	4.30	2.91	1.48	4.30	2.91	1.48
	-5	9.80	2.55	3.84	7.95	2.69	2.96	6.02	2.90	2.08	4.56	3.05	1.50	4.56	3.05	1.50	4.56	3.05	1.50
	-2	10.50	2.69	3.90	8.06	2.87	2.81	6.03	3.08	1.96	4.63	3.20	1.45	3.65	3.25	1.12	3.65	3.25	1.12
	0	10.61	2.76	3.84	8.07	2.96	2.73	5.91	3.15	1.88	4.71	3.36	1.40	3.80	3.40	1.12	3.80	3.40	1.12
	2	10.97	2.86	3.84	8.00	3.15	2.54	5.94	3.35	1.77	5.07	3.57	1.42	3.90	3.65	1.07	3.90	3.65	1.07
	5	10.81	3.19	3.39	8.02	3.65	2.20	6.04	3.90	1.55	5.14	4.14	1.24	3.34	3.48	0.96	3.34	3.48	0.96
	7	11.03	3.50	3.15	8.10	4.00	2.02	6.08	4.31	1.41	5.69	4.53	1.26	3.52	3.64	0.97	3.52	3.64	0.97
	10	11.24	4.00	2.81	7.98	4.61	1.73	5.99	4.91	1.22	5.83	5.07	1.15	3.79	3.86	0.98	3.79	3.86	0.98
	12	11.58	4.31	2.69	8.00	4.92	1.63	6.25	5.26	1.19	6.25	5.26	1.19	3.97	3.96	1.00	3.97	3.96	1.00
	15	10.31	4.76	2.17	8.02	5.20	1.54	6.20	5.61	1.11	6.20	5.61	1.11	4.24	4.13	1.03	4.24	4.13	1.03
	20	9.70	5.41	1.79	8.02	5.80	1.38	6.09	6.11	1.00	6.09	6.11	1.00	4.68	4.37	1.07	4.68	4.37	1.07
25	10.03	5.91	1.70	8.20	6.47	1.27	6.06	6.86	0.88	6.06	6.86	0.88	5.13	4.50	1.14	5.13	4.50	1.14	
30	10.43	6.58	1.59	8.13	7.20	1.13	6.69	7.72	0.87	6.69	7.72	0.87	5.58	4.64	1.20	5.58	4.64	1.20	
35	10.69	7.24	1.48	8.13	8.21	0.99	7.36	8.81	0.84	7.36	8.81	0.84	6.03	5.90	1.02	6.03	5.90	1.02	
50	-25	5.30	1.64	3.23	5.30	1.64	3.23	5.30	1.64	3.23	3.84	1.80	2.13	2.15	1.70	1.26	2.15	1.70	1.26
	-20	6.52	1.92	3.40	6.52	1.92	3.40	5.93	1.98	2.99	3.87	2.08	1.86	2.76	1.80	1.53	2.76	1.80	1.53
	-15	7.44	2.03	3.67	7.44	2.03	3.67	5.98	2.18	2.74	3.88	2.35	1.65	3.25	1.92	1.69	3.25	1.92	1.69
	-10	8.43	2.24	3.76	7.69	2.30	3.34	5.80	2.46	2.36	3.88	2.64	1.47	3.88	2.00	1.94	3.88	2.00	1.94
	-7	8.94	2.34	3.82	7.68	2.45	3.13	5.80	2.54	2.28	4.19	2.74	1.53	4.19	2.15	1.95	4.19	2.15	1.95
	-5	9.43	2.51	3.76	7.72	2.58	2.99	5.79	2.70	2.14	4.62	2.80	1.65	4.62	2.30	2.01	4.62	2.30	2.01
	-2	9.81	2.60	3.77	7.90	2.78	2.84	5.95	2.90	2.05	4.90	2.96	1.66	3.30	2.78	1.19	3.30	2.78	1.19
	0	10.18	2.73	3.73	7.97	2.89	2.76	5.88	2.95	1.99	5.05	3.01	1.68	3.53	2.90	1.22	3.53	2.90	1.22
	2	10.51	2.80	3.75	7.88	2.97	2.65	6.07	3.11	1.95	5.41	3.21	1.69	3.76	3.08	1.22	3.76	3.08	1.22
	5	10.58	3.02	3.50	7.97	3.25	2.45	6.11	3.43	1.78	5.82	3.45	1.69	3.21	3.12	1.03	3.21	3.12	1.03
	7	10.78	3.22	3.35	8.13	3.54	2.30	6.26	3.76	1.66	6.26	3.76	1.66	3.38	3.26	1.04	3.38	3.26	1.04
	10	10.95	3.51	3.12	8.03	3.87	2.07	6.45	4.07	1.58	6.45	4.07	1.59	3.64	3.46	1.05	3.64	3.46	1.05
	12	11.13	3.85	2.89	8.09	4.11	1.97	6.50	4.33	1.50	6.50	4.33	1.50	3.82	3.58	1.07	3.82	3.58	1.07
	15	10.05	4.19	2.40	7.97	4.42	1.80	6.65	4.67	1.42	6.65	4.67	1.42	4.08	3.76	1.09	4.08	3.76	1.09
	20	9.42	4.73	1.99	8.01	4.98	1.61	6.42	5.26	1.22	6.42	5.26	1.22	4.51	4.03	1.12	4.51	4.03	1.12
25	9.74	5.23	1.86	7.95	5.51	1.44	6.28	5.90	1.06	6.28	5.90	1.06	4.95	4.26	1.16	4.95	4.26	1.16	
30	10.14	5.79	1.75	8.13	6.11	1.33	6.92	6.45	1.07	6.92	6.45	1.07	5.38	4.49	1.20	5.38	4.49	1.20	
35	10.42	6.40	1.63	8.11	6.88	1.18	7.61	7.16	1.06	7.61	7.16	1.06	5.82	5.28	1.10	5.82	5.28	1.10	
55	-25	5.14	1.55	3.32	5.14	1.55	3.32	5.14	1.55	3.32	3.83	1.63	2.35	2.45	1.78	1.38	2.45	1.78	1.38
	-20	6.28	1.86	3.38	6.28	1.86	3.38	5.49	1.94	2.83	3.78	2.00	1.89	3.13	1.85	1.69	3.13	1.85	1.69
	-15	7.05	1.96	3.60	7.05	1.96	3.60	5.54	2.09	2.65	3.92	2.14	1.83	3.64	1.90	1.92	3.64	1.90	1.92
	-10	8.01	2.11	3.80	7.55	2.16	3.50	5.61	2.29	2.45	4.33	2.38	1.82	4.33	1.95	2.22	4.33	1.95	2.22
	-7	8.45	2.23	3.79	7.50	2.30	3.26	5.70	2.38	2.39	4.86	2.47	1.97	4.86	2.02	2.41	4.86	2.02	2.41
	-5	8.71	2.26	3.85	7.64	2.41	3.17	5.78	2.51	2.30	5.26	2.60	2.02	5.26	2.10	2.50	5.26	2.10	2.50
	-2	8.97	2.30	3.90	7.78	2.54	3.06	5.91	2.65	2.23	5.46	2.71	2.01	3.11	2.30	1.35	3.11	2.30	1.35
	0	9.10	2.44	3.73	7.79	2.63	2.96	5.93	2.71	2.19	5.57	2.80	1.99	3.45	2.40	1.44	3.45	2.40	1.44
	2	9.27	2.52	3.68	8.00	2.70	2.96	6.10	2.80	2.18	5.85	2.87	2.04	3.84	2.50	1.54	3.84	2.50	1.54
	5	10.04	2.91	3.45	7.97	3.11	2.56	6.24	3.16	1.97	6.12	3.26	1.88	3.30	2.75	1.20	3.30	2.75	1.20
	7	10.49	3.04	3.45	8.00	3.35	2.39	6.35	3.51	1.81	6.35	3.51	1.81	3.48	2.88	1.21	3.48	2.88	1.21
	10	10.71	3.32	3.23	8.10	3.65	2.22	6.41	3.86	1.66	6.41	3.86	1.66	3.75	3.07	1.22	3.75	3.07	1.22
	12	10.84	3.54	3.06	8.17	3.78	2.16	6.53	4.04	1.62	6.53	4.04	1.62	3.93	3.19	1.23	3.93	3.19	1.23
	15	9.93	3.74	2.66	8.00	4.01	2.00	6.35	4.23	1.50	6.35	4.23	1.50	4.20	3.38	1.24	4.20	3.38	1.24
	20	9.29	4.23	2.20	8.06	4.43	1.82	6.26	4.62	1.35	6.26	4.62	1.35	4.65	3.70	1.26	4.65	3.70	1.26
25	9.62	4.59	2.10	8.12	4.87	1.67	6.64	5.08	1.31	6.64	5.08	1.31	5.10	4.02	1.27	5.10	4.02	1.27	
30	10.01	5.02	1.99	8.06	5.42	1.49	7.31	5.60	1.31	7.31	5.60	1.31	5.55	4.33	1.28	5.55	4.33	1.28	
35	10.25	5.54	1.85	8.03	6.05	1.33	8.03	6.05	1.33	8.03	6.05	1.33	6.00	4.65	1.29	6.00	4.65	1.29	
60	-25	4.87	1.26	3.87	4.87	1.26	3.87	4.87	1.26	3.87	3.74	1.44	2.60	2.59	1.60	1.62	2.59	1.60	1.62
	-20	6.00	1.55	3.87	6.00	1.55	3.87	5.45	1.60	3.41	3.74	1.76	2.12	3.30	1.67	1.98	3.30	1.67	1.98
	-15	6.57	1.71	3.84	6.57	1.71	3.84	5.61	1.84	3.05	4.01	1.92	2.09	3.81	1.70	2.24	3.81	1.70	2.24
	-10	7.56	2.00	3.78	7.56	2.00	3.78	5.66	2.15	2.63	4.50	2.23	2.02	4.50	1.75	2.57	4.50	1.75	2.57
	-7	8.22	2.12	3.88	7.57	2.23	3.39	5.68	2.32	2.45	4.91	2.40	2.05	4.91	1.80	2.73	4.91	1.80	2.73
	-5	8.47	2.24	3.78	7.60	2.30	3.30	5.71	2.41	2.37	5.16	2.46	2.10	5.16	1.85	2.79	5.16	1.85	2.79
	-2	8.61	2.30	3.74	7.71	2.42	3.19	5.81	2.53	2.30	5.42	2.59	2.09	3.14	2.05	1.53	3.14	2.05	1.53
	0	8.70	2.34	3.72	7.81	2.46	3.17	5.88	2.62	2.24	5.56	2.66	2.09	3.27	2.15	1.52	3.27	2.15	1.52
	2	8.89	2.39	3.72	7.96	2.51	3.17	5.98	2.68	2.23	5.81	2.72	2.14	3.40	2.27	1.50	3.40	2.27	1.50
	5	9.75	2.62	3.72	7.95	2.76	2.88	6.16	2.92	2.11	6.16	2.92	2.11	3.51	2.45	1.43	3.51	2.45	1.43
	7	10.27	2.74	3.75	7.94	3.00	2.65	6.34	3.18	1.99	6.34	3.18	1.99	3.73	2.56	1.46	3.73	2.56	1.46
	10	10.46	2.94	3.56	7.94	3.20	2.48	6.48	3.48	1.86	6.48	3.48	1.86	4.06	2.72	1.49	4.06	2.72	1.49
	12	10.60	3.15	3.37	7.96	3.39	2.35	6.69	3.65	1.83	6.69	3.65	1.83	4.28	2.82	1.52	4.28	2.82	1.52
	15	9.72	3.40	2.86	7.96	3.60	2.21	6.56	3.84	1.71	6.56	3.84	1.71	4.61	2.98	1.54	4.61	2.98	1.54
	20	9.05	3.76	2.41	8.02	3.94	2.04	6.32	4.16	1.52	6.32								

Table 2-6.1: 8kW heating capacity (continued)

LWT	DB	Maximum			100% (Normal)			75%			50%			25%			Minimum			
		HC	COP	PI	HC	COP	PI	HC	COP	PI	HC	COP	PI	HC	COP	PI	HC	COP	PI	
65	-25	/	/	/	/	/	/	/	/	/	/	/	/	/	/	/	/	/	/	
	-20	5.62	1.46	3.85	5.62	1.46	3.85	5.42	1.47	3.69	3.75	1.50	2.50	3.20	1.54	2.08	3.20	1.54	2.08	
	-15	6.16	1.63	3.78	6.16	1.63	3.78	5.59	1.65	3.39	3.89	1.84	2.11	3.69	1.60	2.31	3.69	1.60	2.31	
	-10	7.30	1.89	3.86	7.15	1.90	3.76	5.60	1.94	2.89	4.35	2.10	2.07	4.35	1.65	2.64	4.35	1.65	2.64	
	-7	7.83	2.04	3.84	7.37	2.05	3.60	5.58	2.14	2.61	4.90	2.21	2.22	4.90	1.70	2.88	4.90	1.70	2.88	
	-5	8.15	2.12	3.84	7.48	2.18	3.43	5.67	2.27	2.50	5.12	2.34	2.19	5.12	1.73	2.96	5.12	1.73	2.96	
	-2	8.28	2.18	3.80	7.81	2.24	3.49	5.83	2.33	2.50	5.25	2.42	2.17	2.94	1.90	1.55	2.94	1.90	1.55	
	0	8.31	2.25	3.69	7.84	2.32	3.38	5.86	2.40	2.44	5.41	2.46	2.20	3.08	2.01	1.53	3.08	2.01	1.53	
	2	8.42	2.29	3.68	7.92	2.35	3.37	5.95	2.43	2.45	5.60	2.50	2.24	3.20	2.12	1.51	3.20	2.12	1.51	
	5	9.02	2.50	3.61	7.93	2.57	3.09	5.89	2.65	2.22	5.89	2.65	2.22	3.43	2.30	1.49	3.43	2.30	1.49	
	7	9.85	2.70	3.65	7.99	2.75	2.91	6.07	2.89	2.10	6.07	2.89	2.10	3.60	2.39	1.51	3.60	2.39	1.51	
	10	9.65	2.81	3.43	8.01	2.98	2.69	6.25	3.08	2.03	6.25	3.08	2.03	3.89	2.52	1.54	3.89	2.52	1.54	
	12	9.88	2.92	3.38	8.17	3.12	2.62	6.46	3.25	1.99	6.46	3.25	1.99	4.09	2.64	1.55	4.09	2.64	1.55	
	15	9.52	3.11	3.06	7.94	3.27	2.43	6.32	3.38	1.87	6.32	3.38	1.87	4.38	2.82	1.56	4.38	2.82	1.56	
	20	8.79	3.42	2.57	7.96	3.52	2.26	6.01	3.65	1.65	6.01	3.65	1.65	4.50	3.10	1.45	4.50	3.10	1.45	
	25	8.99	3.70	2.43	7.91	3.84	2.06	6.23	3.94	1.58	6.23	3.94	1.58	4.65	3.29	1.41	4.65	3.29	1.41	
30	9.23	3.94	2.34	7.96	4.05	1.97	6.59	4.16	1.58	6.59	4.16	1.58	4.72	3.49	1.35	4.72	3.49	1.35		
35	/	/	/	/	/	/	/	/	/	/	/	/	/	/	/	/	/	/		
70	-25	/	/	/	/	/	/	/	/	/	/	/	/	/	/	/	/	/	/	
	-20	5.33	1.37	3.89	5.33	1.37	3.89	5.33	1.37	3.89	3.82	1.45	2.63	3.18	1.40	2.27	3.18	1.40	2.27	
	-15	6.01	1.58	3.80	6.01	1.58	3.80	5.49	1.62	3.39	3.84	1.70	2.26	3.66	1.45	2.52	3.66	1.45	2.52	
	-10	6.88	1.80	3.82	6.88	1.80	3.82	5.60	1.87	2.99	4.31	1.93	2.23	4.31	1.50	2.87	4.31	1.50	2.87	
	-7	7.32	1.96	3.73	7.32	1.96	3.73	5.57	2.09	2.67	4.66	2.15	2.17	4.66	1.55	3.01	4.66	1.55	3.01	
	-5	7.50	2.08	3.61	7.50	2.08	3.61	5.68	2.18	2.61	4.81	2.24	2.15	4.81	1.60	3.01	4.81	1.60	3.01	
	-2	7.67	2.12	3.62	7.67	2.12	3.62	5.88	2.23	2.64	4.91	2.29	2.14	2.74	1.75	1.57	2.74	1.75	1.57	
	0	7.80	2.15	3.63	7.80	2.15	3.63	5.86	2.27	2.58	5.02	2.35	2.14	2.89	1.86	1.55	2.89	1.86	1.55	
	2	7.94	2.17	3.66	7.94	2.17	3.66	5.91	2.31	2.56	5.23	2.40	2.18	3.00	1.96	1.53	3.00	1.96	1.53	
	5	8.22	2.35	3.50	7.96	2.41	3.30	5.99	2.52	2.38	5.64	2.58	2.19	3.35	2.15	1.56	3.35	2.15	1.56	
	7	8.56	2.43	3.52	8.01	2.52	3.18	6.05	2.65	2.28	6.05	2.65	2.28	3.48	2.23	1.56	3.48	2.23	1.56	
	10	8.90	2.62	3.40	8.03	2.71	2.96	6.15	2.82	2.18	6.15	2.82	2.18	3.71	2.32	1.60	3.71	2.32	1.60	
	12	9.08	2.71	3.35	8.07	2.83	2.85	6.27	2.96	2.12	6.27	2.96	2.12	3.89	2.46	1.58	3.89	2.46	1.58	
	15	8.83	2.85	3.10	8.01	2.96	2.71	6.01	3.08	1.95	6.01	3.08	1.95	4.16	2.65	1.57	4.16	2.65	1.57	
	20	8.58	3.10	2.77	8.06	3.18	2.53	5.85	3.32	1.76	5.85	3.32	1.76	4.21	2.95	1.43	4.21	2.95	1.43	
	25	8.68	3.28	2.65	8.16	3.37	2.42	5.97	3.53	1.69	5.97	3.53	1.69	4.30	3.08	1.40	4.30	3.08	1.40	
30	/	/	/	/	/	/	/	/	/	/	/	/	/	/	/	/	/	/	/	
35	/	/	/	/	/	/	/	/	/	/	/	/	/	/	/	/	/	/	/	
75	-25	/	/	/	/	/	/	/	/	/	/	/	/	/	/	/	/	/	/	
	-20	/	/	/	/	/	/	/	/	/	/	/	/	/	/	/	/	/	/	
	-15	5.54	1.44	3.85	5.54	1.44	3.85	5.40	1.46	3.70	3.38	1.54	2.19	3.38	1.24	2.73	3.38	1.24	2.73	
	-10	6.16	1.75	3.52	6.16	1.75	3.52	5.41	1.80	3.01	4.07	1.81	2.25	4.07	1.30	3.13	4.07	1.30	3.13	
	-7	6.59	1.84	3.58	6.59	1.84	3.58	5.47	1.91	2.86	4.39	1.95	2.25	4.39	1.35	3.25	4.39	1.35	3.25	
	-5	6.84	1.90	3.60	6.84	1.90	3.60	5.45	1.96	2.78	4.56	1.98	2.31	4.56	1.40	3.26	4.56	1.40	3.26	
	-2	6.97	1.97	3.54	6.97	1.97	3.54	5.48	2.06	2.66	4.70	2.12	2.22	2.55	1.60	1.59	2.55	1.60	1.59	
	0	7.10	2.00	3.55	7.10	2.00	3.55	5.50	2.10	2.62	4.77	2.17	2.20	2.69	1.72	1.57	2.69	1.72	1.57	
	2	7.23	2.02	3.58	7.23	2.02	3.58	5.51	2.15	2.56	5.02	2.23	2.25	2.80	1.81	1.55	2.80	1.81	1.55	
	5	7.65	2.09	3.66	7.65	2.09	3.66	5.56	2.20	2.53	5.42	2.28	2.38	3.27	2.00	1.64	3.27	2.00	1.64	
	7	7.82	2.14	3.65	7.82	2.14	3.65	5.76	2.32	2.48	5.76	2.32	2.48	3.35	2.06	1.62	3.35	2.06	1.62	
	10	7.91	2.31	3.42	7.91	2.31	3.42	5.88	2.47	2.38	5.88	2.47	2.38	3.54	2.13	1.66	3.54	2.13	1.66	
	12	8.05	2.44	3.30	8.05	2.44	3.30	6.00	2.63	2.28	6.00	2.63	2.28	3.70	2.28	1.62	3.70	2.28	1.62	
	15	7.90	2.60	3.04	7.90	2.60	3.04	5.74	2.82	2.04	5.74	2.82	2.04	3.93	2.49	1.58	3.93	2.49	1.58	
	20	7.73	2.86	2.70	7.73	2.86	2.70	5.56	3.04	1.83	5.56	3.04	1.83	4.18	2.72	1.54	4.18	2.72	1.54	
	25	/	/	/	/	/	/	/	/	/	/	/	/	/	/	/	/	/	/	/
30	/	/	/	/	/	/	/	/	/	/	/	/	/	/	/	/	/	/	/	
35	/	/	/	/	/	/	/	/	/	/	/	/	/	/	/	/	/	/	/	
80	-25	/	/	/	/	/	/	/	/	/	/	/	/	/	/	/	/	/	/	
	-20	/	/	/	/	/	/	/	/	/	/	/	/	/	/	/	/	/	/	
	-15	/	/	/	/	/	/	/	/	/	/	/	/	/	/	/	/	/	/	
	-10	5.52	1.52	3.63	5.52	1.52	3.63	5.16	1.54	3.35	3.80	1.56	2.44	3.80	1.20	3.17	3.80	1.20	3.17	
	-7	5.84	1.55	3.77	5.84	1.55	3.77	5.23	1.60	3.27	4.02	1.62	2.48	4.02	1.25	3.22	4.02	1.25	3.22	
	-5	5.97	1.62	3.69	5.97	1.62	3.69	5.26	1.66	3.17	4.21	1.70	2.48	4.21	1.30	3.24	4.21	1.30	3.24	
	-2	6.04	1.68	3.60	6.04	1.68	3.60	5.29	1.73	3.06	4.35	1.78	2.44	4.35	1.45	1.62	4.35	1.45	1.62	
	0	6.17	1.74	3.55	6.17	1.74	3.55	5.34	1.79	2.98	4.52	1.84	2.46	2.50	1.57	1.59	2.50	1.57	1.59	
	2	6.38	1.78	3.58	6.38	1.78	3.58	5.37	1.84	2.92	4.68	1.90	2.46	2.60	1.65	1.58	2.60	1.65	1.58	
	5	6.58	1.85	3.56	6.58	1.85	3.56	5.39	1.92	2.81	4.87	1.98	2.46	3.19	1.85	1.72	3.19	1.85	1.72	
	7	6.81	1.91	3.57	6.81	1.91	3.57	5.42	1.96	2.77	4.94	2.02	2.45	3.22	1.90	1.69	3.22	1.90	1.69	
	10	6.92	2.00	3.46	6.92	2.00	3.46	5.51	2.08	2.65	5.05	2.12	2.38	3.37	1.93	1.74	3.37	1.93	1.74	
	12	7.03	2.06	3.41	7.03	2.06	3.41	5.62	2.14	2.63	5.14	2.19	2.35	3.50	2.10	1.67	3.50	2.10	1.67	
	15	6.87	2.15	3.20	6.87	2.15	3.20	5.40	2.22	2.43	4.99	2.26	2.21	3.71	2.32	1.60	3.71	2.32	1.60	
	20	/	/	/	/	/	/	/	/	/	/	/	/	/	/	/	/	/	/	/
	25	/	/	/	/	/	/	/	/	/	/	/	/	/	/	/	/	/	/	/
30	/	/	/	/	/	/	/	/	/	/	/	/	/	/	/	/	/	/	/	
35	/	/	/	/	/	/	/	/	/	/	/	/	/	/	/	/	/	/	/	

Abbreviations:

LWT: Leaving water temperature (°C)

DB: Dry-bulb temperature for outdoor air temperature (°C)

HC: Total heating capacity (kW)

PI: Power input (kW)

R290 M thermal Nature Plus Series



Table 2-6.2: 10kW heating capacity

LWT	DB	Maximum			100% (Normal)			75%			50%			25%			Minimum		
		HC	COP	PI	HC	COP	PI	HC	COP	PI	HC	COP	PI	HC	COP	PI	HC	COP	PI
25	-25	6.47	2.09	3.10	6.47	2.09	3.10	6.01	2.12	2.83	4.05	2.34	1.73	1.97	3.00	0.66	1.97	3.00	0.66
	-20	7.61	2.35	3.24	7.61	2.35	3.24	6.05	2.49	2.43	4.01	2.80	1.43	2.45	3.25	0.75	2.45	3.25	0.75
	-15	8.66	2.73	3.17	7.95	2.81	2.83	6.04	3.09	1.95	3.91	3.54	1.10	2.94	3.78	0.78	2.94	3.78	0.78
	-10	9.83	3.00	3.28	7.94	3.58	2.22	5.93	3.91	1.52	4.02	4.30	0.93	3.32	4.38	0.76	3.32	4.38	0.76
	-7	10.32	3.36	3.07	8.11	3.81	2.13	5.90	4.24	1.39	3.98	4.65	0.86	3.58	4.70	0.76	3.58	4.70	0.76
	-5	10.60	3.54	2.99	8.03	4.05	1.98	5.98	4.55	1.31	4.02	4.84	0.83	3.67	4.91	0.75	3.67	4.91	0.75
	-2	11.32	3.86	2.93	8.17	4.49	1.82	6.02	5.09	1.18	4.03	5.47	0.74	3.70	5.50	0.67	3.70	5.50	0.67
	0	11.59	4.00	2.90	8.19	4.74	1.73	6.10	5.26	1.16	4.01	5.69	0.70	3.94	5.88	0.67	3.94	5.88	0.67
	2	12.06	4.23	2.85	8.28	5.07	1.63	6.19	5.57	1.11	4.28	5.98	0.72	4.18	6.20	0.67	4.18	6.20	0.67
	5	12.57	5.40	2.33	8.86	6.05	1.46	6.63	6.40	1.04	4.36	6.90	0.63	3.85	7.00	0.55	3.85	7.00	0.55
	7	12.92	5.86	2.20	9.57	6.50	1.47	7.31	7.08	1.03	4.65	7.61	0.61	3.99	7.50	0.53	3.99	7.50	0.53
	10	13.32	6.64	2.01	9.58	7.39	1.30	7.30	8.07	0.90	5.12	8.50	0.60	4.20	7.90	0.53	4.20	7.90	0.53
	12	13.61	7.40	1.84	9.50	7.99	1.19	7.19	8.65	0.83	5.48	9.06	0.60	4.55	8.80	0.52	4.55	8.80	0.52
	15	12.02	8.03	1.50	9.80	8.69	1.13	7.37	9.21	0.80	4.88	9.58	0.51	4.65	9.10	0.51	4.65	9.10	0.51
	20	11.40	9.12	1.25	9.75	9.59	1.02	7.21	10.06	0.72	4.82	10.41	0.46	4.82	9.56	0.50	4.82	9.56	0.50
	25	11.66	10.02	1.16	9.73	10.63	0.92	7.12	11.19	0.64	5.01	11.52	0.43	5.01	11.05	0.45	5.01	11.05	0.45
30	/	/	/	/	/	/	/	/	/	/	/	/	/	/	/	/	/	/	/
35	/	/	/	/	/	/	/	/	/	/	/	/	/	/	/	/	/	/	/
30	-25	6.35	1.90	3.34	6.35	1.90	3.34	5.99	1.94	3.09	4.16	2.21	1.88	1.89	2.70	0.70	1.89	2.70	0.70
	-20	7.58	2.22	3.41	7.58	2.22	3.41	6.06	2.32	2.61	3.93	2.66	1.48	2.37	3.10	0.76	2.37	3.10	0.76
	-15	8.59	2.40	3.58	7.92	2.62	3.02	5.95	2.92	2.04	3.96	3.26	1.21	2.86	3.58	0.80	2.86	3.58	0.80
	-10	9.65	2.73	3.53	7.92	3.18	2.49	5.92	3.59	1.65	4.00	3.78	1.06	3.42	3.92	0.87	3.42	3.92	0.87
	-7	10.19	3.09	3.30	7.96	3.46	2.30	5.91	3.95	1.50	3.97	4.15	0.96	3.80	4.18	0.91	3.80	4.18	0.91
	-5	10.42	3.28	3.18	8.00	3.73	2.14	5.97	4.19	1.42	4.01	4.48	0.90	3.91	4.50	0.87	3.91	4.50	0.87
	-2	11.13	3.51	3.17	8.12	4.11	1.98	6.01	4.63	1.30	4.02	4.99	0.81	3.64	5.01	0.73	3.64	5.01	0.73
	0	11.39	3.62	3.15	8.15	4.32	1.89	6.05	4.75	1.27	4.05	5.18	0.78	3.88	5.30	0.73	3.88	5.30	0.73
	2	11.87	3.91	3.04	8.35	4.52	1.85	6.15	5.03	1.22	4.19	5.45	0.77	3.94	5.43	0.73	3.94	5.43	0.73
	5	12.40	4.44	2.79	8.85	5.16	1.72	6.70	5.62	1.19	4.26	6.11	0.70	3.78	6.30	0.60	3.78	6.30	0.60
	7	12.75	5.07	2.51	9.69	5.67	1.71	7.16	6.31	1.13	4.55	6.67	0.68	3.95	6.85	0.58	3.95	6.85	0.58
	10	13.12	5.81	2.26	9.58	6.36	1.51	7.31	6.88	1.06	5.03	7.35	0.68	4.06	7.60	0.53	4.06	7.60	0.53
	12	13.40	6.18	2.17	9.57	6.79	1.41	7.06	7.31	0.97	5.38	7.62	0.71	4.37	8.10	0.54	4.37	8.10	0.54
	15	11.83	6.73	1.76	9.77	7.10	1.38	7.21	7.67	0.94	4.78	8.20	0.58	4.48	8.27	0.54	4.48	8.27	0.54
	20	11.22	7.83	1.43	9.77	8.22	1.19	7.29	8.64	0.84	4.71	9.16	0.51	4.55	8.63	0.53	4.55	8.63	0.53
	25	11.51	8.89	1.29	9.66	9.38	1.03	7.24	10.01	0.72	4.94	10.35	0.48	4.80	9.01	0.53	4.80	9.01	0.53
30	11.62	10.11	1.15	9.64	10.65	0.91	7.20	11.36	0.63	5.43	11.63	0.47	5.18	9.52	0.54	5.18	9.52	0.54	
35	/	/	/	/	/	/	/	/	/	/	/	/	/	/	/	/	/	/	/
35	-25	6.28	1.89	3.32	6.28	1.89	3.32	6.01	1.90	3.16	4.16	2.09	1.99	1.82	2.38	0.76	1.82	2.38	0.76
	-20	7.52	2.18	3.45	7.52	2.18	3.45	6.04	2.24	2.70	3.99	2.53	1.58	2.28	2.72	0.84	2.28	2.72	0.84
	-15	8.09	2.22	3.64	7.97	2.40	3.32	6.00	2.59	2.32	4.00	2.84	1.41	2.76	3.06	0.90	2.76	3.06	0.90
	-10	9.75	2.67	3.65	8.00	2.89	2.77	5.89	3.16	1.86	3.97	3.31	1.20	3.31	3.36	0.99	3.31	3.36	0.99
	-7	9.64	2.70	3.57	8.00	3.15	2.54	5.93	3.50	1.69	3.97	3.65	1.09	3.78	3.67	1.03	3.78	3.67	1.03
	-5	10.28	3.03	3.39	7.99	3.42	2.34	5.95	3.82	1.56	4.07	4.00	1.02	4.07	4.00	1.02	4.07	4.00	1.02
	-2	11.00	3.35	3.28	8.12	3.76	2.16	5.98	4.28	1.40	4.07	4.42	0.92	3.54	4.35	0.81	3.54	4.35	0.81
	0	11.20	3.47	3.23	8.08	3.86	2.09	6.12	4.30	1.42	4.05	4.66	0.87	3.77	4.55	0.83	3.77	4.55	0.83
	2	11.68	3.70	3.16	8.20	3.90	2.10	6.11	4.34	1.41	4.08	4.75	0.86	3.89	4.75	0.82	3.89	4.75	0.82
	5	12.22	3.82	3.20	8.95	4.55	1.97	6.68	4.96	1.35	4.36	5.36	0.81	3.64	5.40	0.67	3.64	5.40	0.67
	7	12.57	4.33	2.90	9.50	4.95	1.92	7.23	5.41	1.34	4.65	5.93	0.78	3.71	5.65	0.66	3.71	5.65	0.66
	10	13.01	4.95	2.63	9.56	5.52	1.73	7.10	6.06	1.17	4.96	6.58	0.75	3.99	5.79	0.69	3.99	5.79	0.69
	12	13.18	5.48	2.41	9.67	6.03	1.60	7.05	6.60	1.07	5.05	6.90	0.73	4.40	6.95	0.63	4.40	6.95	0.63
	15	11.61	6.00	1.94	9.75	6.45	1.51	7.26	6.98	1.04	4.77	7.57	0.63	4.50	7.30	0.62	4.50	7.30	0.62
	20	11.02	6.91	1.59	9.76	7.28	1.34	7.13	7.78	0.92	4.68	8.41	0.56	4.70	8.00	0.59	4.70	8.00	0.59
	25	11.30	7.82	1.45	9.59	8.31	1.15	7.10	8.81	0.81	4.81	9.39	0.51	5.00	8.47	0.59	5.00	8.47	0.59
30	11.40	8.91	1.28	9.45	9.45	1.00	7.06	10.02	0.70	5.30	10.71	0.49	5.20	9.02	0.58	5.20	9.02	0.58	
35	11.54	9.96	1.16	9.36	10.70	0.87	7.20	11.46	0.63	5.83	11.92	0.49	5.60	9.35	0.60	5.60	9.35	0.60	
40	-25	6.23	1.83	3.40	6.23	1.83	3.40	6.23	1.83	3.40	4.25	1.92	2.21	1.81	2.06	0.88	1.81	2.06	0.88
	-20	7.50	2.13	3.52	7.50	2.13	3.52	6.37	2.17	2.94	4.22	2.34	1.80	2.35	2.48	0.95	2.35	2.48	0.95
	-15	8.52	2.20	3.87	8.32	2.20	3.78	6.37	2.35	2.71	4.20	2.62	1.60	2.82	2.81	1.00	2.82	2.81	1.00
	-10	9.44	2.37	3.98	8.37	2.65	3.16	6.29	2.89	2.18	4.19	3.00	1.40	3.39	3.17	1.07	3.39	3.17	1.07
	-7	9.60	2.64	3.64	8.45	2.95	2.86	6.31	3.09	2.04	4.25	3.38	1.26	3.86	3.45	1.12	3.86	3.45	1.12
	-5	9.71	2.96	3.28	8.46	3.12	2.71	6.33	3.28	1.93	4.28	3.57	1.20	4.17	3.63	1.15	4.17	3.63	1.15
	-2	10.84	3.12	3.47	8.53	3.25	2.62	6.39	3.61	1.77	4.30	3.78	1.14	3.50	3.85	0.91	3.50	3.85	0.91
	0	11.00	3.22	3.42	8.61	3.33	2.59	6.39	3.69	1.73	4.39	3.92	1.12	3.72	4.00	0.93	3.72	4.00	0.93
	2	11.51	3.53	3.26	8.67	3.61	2.40	6.38	3.82	1.67	4.71	4.18	1.13	3.82	4.25	0.90	3.82	4.25	0.90
	5	12.06	3.74	3.22	9.16	4.03	2.27	6.85	4.39	1.56	4.89	4.86	1.01	3.37	4.44	0.76	3.37	4.44	0.76
	7	12.45	3.94	3.16	9.52	4.53	2.10	7.20	4.86	1.48	5.23	5.30	0.99	3.49	4.65	0.75	3.49	4.65	0.75
	10	12.99	4.35	2.99	9.59	4.90	1.96	7.26	5.37	1.35	5.43	5.79	0.94	3.75	4.82	0.78	3.75	4.82	0.78
	12	13.01	4.68	2.78	9.75	5.36	1.82	7.27	5.85	1.24	5.62	6.25	0.90	4.04	5.45	0.74	4.04	5.45	0.74
	15	11.38	5.21	2.18	9.56	5.81	1.65	7.29	6.21	1.17	5.62	6.70	0.84	4.18	5.71	0.73	4.18	5.71	0.73
	20	10.82	6.01	1.80	9.46	6.51	1.45	7.27	6.95	1.05	5.13	7.46	0.69	4.53	6.18	0.73	4.53	6.18	0.73
	25	11.07	6.86	1.61	9.53	7.34	1.30	7.14	7.75	0.92									

Table 2-6.2: 10kW heating capacity (continued)

LWT	DB	Maximum			100% (Normal)			75%			50%			25%			Minimum		
		HC	COP	PI	HC	COP	PI	HC	COP	PI	HC	COP	PI	HC	COP	PI	HC	COP	PI
45	-25	6.21	1.72	3.61	6.21	1.72	3.61	6.21	1.72	3.61	4.50	1.83	2.46	2.11	1.96	1.08	2.11	1.96	1.08
	-20	7.46	2.04	3.66	7.46	2.04	3.66	6.63	2.14	3.10	4.47	2.21	2.02	2.68	2.31	1.16	2.68	2.31	1.16
	-15	8.44	2.11	4.00	8.44	2.11	4.00	6.74	2.28	2.96	4.47	2.40	1.86	3.19	2.52	1.27	3.19	2.52	1.27
	-10	9.45	2.30	4.11	8.91	2.41	3.70	6.71	2.50	2.68	4.47	2.64	1.69	3.80	2.72	1.40	3.80	2.72	1.40
	-7	9.55	2.42	3.95	9.00	2.50	3.60	6.66	2.64	2.52	4.49	2.88	1.56	4.30	2.91	1.48	4.30	2.91	1.48
	-5	10.01	2.54	3.94	9.03	2.56	3.53	6.72	2.76	2.43	4.56	3.05	1.50	4.56	3.05	1.50	4.56	3.05	1.50
	-2	10.73	2.65	4.05	9.06	2.74	3.31	6.76	2.90	2.33	4.63	3.20	1.45	3.65	3.25	1.12	3.65	3.25	1.12
	0	10.81	2.70	4.00	9.08	2.82	3.22	6.83	3.00	2.28	4.71	3.36	1.40	3.80	3.40	1.12	3.80	3.40	1.12
	2	11.37	2.84	4.00	9.00	3.05	2.95	6.74	3.24	2.08	5.07	3.57	1.42	3.90	3.65	1.07	3.90	3.65	1.07
	5	11.90	3.10	3.84	9.23	3.44	2.68	7.10	3.72	1.91	5.14	4.14	1.24	3.34	3.48	0.96	3.34	3.48	0.96
	7	12.18	3.42	3.56	9.50	3.90	2.44	7.36	4.12	1.79	5.69	4.53	1.26	3.52	3.64	0.97	3.52	3.64	0.97
	10	12.45	3.86	3.23	9.52	4.40	2.16	7.17	4.71	1.52	5.83	5.07	1.15	3.79	3.86	0.98	3.79	3.86	0.98
	12	12.76	4.28	2.98	9.55	4.69	2.04	7.25	5.00	1.45	6.25	5.26	1.19	3.97	3.96	1.00	3.97	3.96	1.00
	15	11.17	4.63	2.41	9.50	4.98	1.91	7.29	5.36	1.36	6.20	5.61	1.11	4.24	4.13	1.03	4.24	4.13	1.03
	20	10.58	5.26	2.01	9.45	5.57	1.70	7.28	5.93	1.23	6.09	6.11	1.00	4.68	4.37	1.07	4.68	4.37	1.07
	25	10.81	5.81	1.86	9.53	6.26	1.52	7.16	6.65	1.08	6.06	6.86	0.88	5.13	4.50	1.14	5.13	4.50	1.14
30	10.89	6.51	1.67	9.56	7.01	1.36	7.15	7.56	0.95	6.69	7.72	0.87	5.58	4.64	1.20	5.58	4.64	1.20	
35	11.01	7.18	1.53	9.57	8.02	1.19	7.36	8.81	0.84	7.36	8.81	0.84	6.03	5.90	1.02	6.03	5.90	1.02	
50	-25	5.99	1.60	3.74	5.99	1.60	3.74	5.99	1.60	3.74	4.42	1.76	2.51	2.15	1.70	1.26	2.15	1.70	1.26
	-20	7.22	1.86	3.88	7.22	1.86	3.88	6.50	1.94	3.35	4.36	2.04	2.14	2.76	1.80	1.53	2.76	1.80	1.53
	-15	8.16	2.00	4.08	8.16	2.00	4.08	6.65	2.16	3.08	4.45	2.24	1.99	3.25	1.92	1.69	3.25	1.92	1.69
	-10	9.13	2.18	4.19	8.75	2.22	3.94	6.60	2.36	2.80	4.43	2.48	1.79	3.88	2.00	1.94	3.88	2.00	1.94
	-7	9.47	2.30	4.12	8.90	2.35	3.79	6.62	2.46	2.69	4.59	2.72	1.69	4.19	2.15	1.95	4.19	2.15	1.95
	-5	9.64	2.35	4.10	8.93	2.53	3.53	6.59	2.65	2.49	4.62	2.80	1.65	4.62	2.30	2.01	4.62	2.30	2.01
	-2	10.05	2.48	4.05	9.01	2.70	3.34	6.63	2.82	2.35	4.90	2.96	1.66	3.30	2.78	1.19	3.30	2.78	1.19
	0	10.38	2.50	4.15	9.05	2.81	3.22	6.77	2.92	2.32	5.05	3.01	1.68	3.53	2.90	1.22	3.53	2.90	1.22
	2	10.93	2.62	4.17	9.06	2.87	3.16	6.74	3.10	2.17	5.41	3.21	1.69	3.76	3.08	1.22	3.76	3.08	1.22
	5	11.44	2.78	4.12	9.21	3.08	2.99	7.04	3.31	2.13	5.82	3.45	1.69	3.21	3.12	1.03	3.21	3.12	1.03
	7	11.79	3.10	3.80	9.48	3.39	2.80	7.18	3.63	1.98	6.26	3.76	1.66	3.38	3.26	1.04	3.38	3.26	1.04
	10	12.29	3.38	3.64	9.51	3.72	2.56	7.16	3.91	1.83	6.45	4.07	1.58	3.64	3.46	1.05	3.64	3.46	1.05
	12	12.23	3.65	3.35	9.49	3.95	2.40	7.11	4.22	1.68	6.50	4.33	1.50	3.82	3.58	1.07	3.82	3.58	1.07
	15	10.92	4.01	2.72	9.53	4.26	2.24	7.30	4.54	1.61	6.65	4.67	1.42	4.08	3.76	1.09	4.08	3.76	1.09
	20	10.40	4.50	2.31	9.57	4.70	2.04	7.28	5.18	1.41	6.42	5.26	1.22	4.51	4.03	1.12	4.51	4.03	1.12
	25	10.53	4.94	2.13	9.43	5.31	1.78	7.16	5.90	1.21	6.28	5.90	1.06	4.95	4.26	1.16	4.95	4.26	1.16
30	10.59	5.58	1.90	9.56	5.96	1.60	7.17	6.45	1.11	6.92	6.45	1.07	5.38	4.49	1.20	5.38	4.49	1.20	
35	10.72	6.21	1.73	9.62	6.72	1.43	7.61	7.16	1.06	7.61	7.16	1.06	5.82	5.28	1.10	5.82	5.28	1.10	
55	-25	5.76	1.51	3.81	5.76	1.51	3.81	5.76	1.51	3.81	4.42	1.62	2.73	2.45	1.78	1.38	2.45	1.78	1.38
	-20	6.95	1.77	3.93	6.95	1.77	3.93	6.45	1.85	3.49	4.35	1.98	2.20	3.13	1.85	1.69	3.13	1.85	1.69
	-15	7.94	1.93	4.11	7.94	1.93	4.11	6.57	2.03	3.24	4.48	2.11	2.12	3.64	1.90	1.92	3.64	1.90	1.92
	-10	8.65	2.08	4.16	8.65	2.08	4.16	6.51	2.24	2.91	4.33	2.38	1.82	4.33	1.95	2.22	4.33	1.95	2.22
	-7	8.99	2.14	4.20	8.80	2.20	4.00	6.53	2.32	2.81	4.86	2.47	1.97	4.86	2.02	2.41	4.86	2.02	2.41
	-5	9.13	2.21	4.13	8.81	2.25	3.92	6.59	2.49	2.65	5.26	2.60	2.02	5.26	2.10	2.50	5.26	2.10	2.50
	-2	9.46	2.28	4.15	8.89	2.32	3.83	6.61	2.56	2.58	5.46	2.71	2.01	3.11	2.30	1.35	3.11	2.30	1.35
	0	9.60	2.30	4.17	8.96	2.44	3.67	6.73	2.64	2.55	5.57	2.80	1.99	3.45	2.40	1.44	3.45	2.40	1.44
	2	9.81	2.41	4.07	9.00	2.55	3.53	6.83	2.80	2.44	5.85	2.87	2.04	3.84	2.50	1.54	3.84	2.50	1.54
	5	10.73	2.67	4.02	9.27	2.93	3.16	6.88	3.14	2.19	6.12	3.26	1.88	3.30	2.75	1.20	3.30	2.75	1.20
	7	11.54	2.96	3.90	9.50	3.20	2.97	7.23	3.45	2.10	6.35	3.51	1.81	3.48	2.88	1.21	3.48	2.88	1.21
	10	11.85	3.15	3.76	9.54	3.43	2.78	7.21	3.70	1.95	6.41	3.86	1.66	3.75	3.07	1.22	3.75	3.07	1.22
	12	12.08	3.32	3.64	9.56	3.60	2.66	7.30	3.85	1.90	6.53	4.04	1.62	3.93	3.19	1.23	3.93	3.19	1.23
	15	10.70	3.55	3.01	9.45	3.86	2.45	7.24	4.08	1.77	6.35	4.23	1.50	4.20	3.38	1.24	4.20	3.38	1.24
	20	10.35	4.00	2.59	9.41	4.20	2.24	7.19	4.45	1.62	6.26	4.62	1.35	4.65	3.70	1.26	4.65	3.70	1.26
	25	10.50	4.36	2.41	9.51	4.66	2.04	7.07	4.92	1.44	6.64	5.08	1.31	5.10	4.02	1.27	5.10	4.02	1.27
30	10.52	4.80	2.19	9.52	5.07	1.88	7.31	5.60	1.31	7.31	5.60	1.31	5.55	4.33	1.28	5.55	4.33	1.28	
35	10.63	5.12	2.08	9.56	5.69	1.68	8.03	6.05	1.33	8.03	6.05	1.33	6.00	4.65	1.29	6.00	4.65	1.29	
60	-25	5.01	1.23	4.07	5.01	1.23	4.07	5.01	1.23	4.07	4.41	1.38	3.20	2.59	1.60	1.62	2.59	1.60	1.62
	-20	6.23	1.52	4.10	6.23	1.52	4.10	6.23	1.52	4.10	4.44	1.73	2.57	3.30	1.67	1.98	3.30	1.67	1.98
	-15	7.02	1.69	4.15	7.02	1.69	4.15	6.57	1.71	3.84	4.45	1.89	2.35	3.81	1.70	2.24	3.81	1.70	2.24
	-10	7.94	1.91	4.16	7.94	1.91	4.16	6.67	2.07	3.22	4.50	2.23	2.02	4.50	1.75	2.57	4.50	1.75	2.57
	-7	8.54	2.10	4.07	8.54	2.10	4.07	6.48	2.26	2.88	4.91	2.40	2.05	4.91	1.80	2.73	4.91	1.80	2.73
	-5	9.01	2.18	4.13	8.63	2.22	3.89	6.53	2.38	2.74	5.16	2.46	2.10	5.16	1.85	2.79	5.16	1.85	2.79
	-2	9.38	2.24	4.19	8.70	2.30	3.78	6.56	2.50	2.62	5.42	2.59	2.09	3.14	2.05	1.53	3.14	2.05	1.53
	0	9.37	2.28	4.11	8.72	2.34	3.73	6.62	2.56	2.59	5.56	2.66	2.09	3.27	2.15	1.52	3.27	2.15	1.52
	2	9.54	2.33	4.09	8.76	2.39	3.67	6.71	2.61	2.57	5.81	2.72	2.14	3.40	2.27	1.50	3.40	2.27	1.50
	5	10.63	2.56	4.15	9.18	2.68	3.43	6.94	2.85	2.44	6.16	2.92	2.11	3.51	2.45	1.43	3.51	2.45	1.43
	7	10.86	2.70	4.02	9.51	2.85	3.34	7.10	3.04	2.34	6.34	3.18	1.99	3.73	2.56	1.46	3.73	2.56	1.46
	10	10.77	2.91	3.70	9.48	3.06	3.10	7.04	3.28	2.15	6.48	3.48	1.86	4.06	2.72	1.49	4.06	2.72	1.49
	12	11.02	3.06	3.60	9.50	3.23	2.94	7.14	3.45	2.07	6.69	3.65	1.83	4.28	2.82	1.52	4.28	2.82	1.52
	15	10.65	3.25	3.28	9.44	3.42	2.76	7.23	3.65	1.98	6.56	3.84	1.71	4.61	2.98	1.54	4.61	2.98	1.54
	20	9.94	3.65	2.72	9.42	3.72	2.53	7.08	4.02	1.76</									

R290 M thermal Nature Plus Series



Table 2-6.2: 10kW heating capacity (continued)

LWT	DB	Maximum			100% (Normal)			75%			50%			25%			Minimum		
		HC	COP	PI	HC	COP	PI	HC	COP	PI	HC	COP	PI	HC	COP	PI	HC	COP	PI
65	-25	/	/	/	/	/	/	/	/	/	/	/	/	/	/	/	/	/	/
	-20	5.79	1.41	4.11	5.79	1.41	4.11	5.79	1.41	4.11	4.45	1.48	3.01	3.20	1.54	2.08	3.20	1.54	2.08
	-15	6.51	1.58	4.12	6.51	1.58	4.12	6.51	1.58	4.12	4.33	1.75	2.47	3.69	1.60	2.31	3.69	1.60	2.31
	-10	7.52	1.89	3.98	7.52	1.89	3.98	6.67	1.92	3.47	4.35	2.10	2.07	4.35	1.65	2.64	4.35	1.65	2.64
	-7	8.14	1.98	4.11	8.14	1.98	4.11	6.64	2.08	3.19	4.90	2.21	2.22	4.90	1.70	2.88	4.90	1.70	2.88
	-5	8.32	2.11	3.94	8.32	2.11	3.94	6.62	2.24	2.96	5.12	2.34	2.19	5.12	1.73	2.96	5.12	1.73	2.96
	-2	8.46	2.16	3.92	8.46	2.16	3.92	6.67	2.33	2.86	5.25	2.42	2.17	2.94	1.90	1.55	2.94	1.90	1.55
	0	8.49	2.20	3.86	8.49	2.20	3.86	6.65	2.38	2.79	5.41	2.46	2.20	3.08	2.01	1.53	3.08	2.01	1.53
	2	8.53	2.26	3.77	8.53	2.26	3.77	6.68	2.40	2.78	5.60	2.50	2.24	3.20	2.12	1.51	3.20	2.12	1.51
	5	9.72	2.40	4.05	9.20	2.46	3.74	6.85	2.60	2.63	5.89	2.65	2.22	3.43	2.30	1.49	3.43	2.30	1.49
	7	9.95	2.67	3.73	9.85	2.70	3.65	7.07	2.78	2.54	6.07	2.89	2.10	3.60	2.39	1.51	3.60	2.39	1.51
	10	10.14	2.75	3.69	9.48	2.83	3.35	7.07	3.01	2.35	6.25	3.08	2.03	3.89	2.52	1.54	3.89	2.52	1.54
	12	10.40	2.89	3.60	9.51	2.98	3.19	7.02	3.12	2.25	6.46	3.25	1.99	4.09	2.64	1.55	4.09	2.64	1.55
	15	9.94	3.08	3.23	9.45	3.14	3.01	7.16	3.28	2.18	6.32	3.38	1.87	4.38	2.82	1.56	4.38	2.82	1.56
	20	9.59	3.35	2.86	9.44	3.37	2.80	7.11	3.52	2.02	6.01	3.65	1.65	4.50	3.10	1.45	4.50	3.10	1.45
	25	9.75	3.62	2.69	9.47	3.68	2.57	7.14	3.89	1.84	6.23	3.94	1.58	4.65	3.29	1.41	4.65	3.29	1.41
30	9.69	3.90	2.48	9.51	3.91	2.43	7.03	4.10	1.71	6.59	4.16	1.58	4.72	3.49	1.35	4.72	3.49	1.35	
35	/	/	/	/	/	/	/	/	/	/	/	/	/	/	/	/	/	/	
70	-25	/	/	/	/	/	/	/	/	/	/	/	/	/	/	/	/	/	/
	-20	5.52	1.35	4.09	5.52	1.35	4.09	5.52	1.35	4.09	4.36	1.40	3.11	3.18	1.40	2.27	3.18	1.40	2.27
	-15	6.14	1.51	4.07	6.14	1.51	4.07	6.14	1.51	4.07	4.41	1.64	2.69	3.66	1.45	2.52	3.66	1.45	2.52
	-10	7.40	1.78	4.16	7.40	1.78	4.16	6.67	1.84	3.62	4.52	1.89	2.39	4.31	1.50	2.87	4.31	1.50	2.87
	-7	7.78	1.93	4.03	7.78	1.93	4.03	6.71	2.01	3.34	4.66	2.15	2.17	4.66	1.55	3.01	4.66	1.55	3.01
	-5	7.92	1.99	3.98	7.92	1.99	3.98	6.74	2.13	3.16	4.81	2.24	2.15	4.81	1.60	3.01	4.81	1.60	3.01
	-2	8.01	2.08	3.85	8.01	2.08	3.85	6.70	2.20	3.05	4.91	2.29	2.14	2.74	1.75	1.57	2.74	1.75	1.57
	0	8.05	2.11	3.82	8.05	2.11	3.82	6.77	2.24	3.02	5.02	2.35	2.14	2.89	1.86	1.55	2.89	1.86	1.55
	2	8.14	2.14	3.80	8.14	2.14	3.80	6.86	2.29	3.00	5.23	2.40	2.18	3.00	1.96	1.53	3.00	1.96	1.53
	5	9.05	2.24	4.04	9.05	2.24	4.04	6.93	2.47	2.81	5.64	2.58	2.19	3.35	2.15	1.56	3.35	2.15	1.56
	7	9.16	2.35	3.90	9.16	2.35	3.90	7.06	2.60	2.72	6.05	2.65	2.28	3.48	2.23	1.56	3.48	2.23	1.56
	10	9.25	2.51	3.69	9.25	2.51	3.69	7.12	2.75	2.59	6.15	2.82	2.18	3.71	2.32	1.60	3.71	2.32	1.60
	12	9.32	2.62	3.56	9.32	2.62	3.56	7.17	2.90	2.47	6.27	2.96	2.12	3.89	2.46	1.58	3.89	2.46	1.58
	15	9.27	2.78	3.33	9.27	2.78	3.33	7.09	3.01	2.36	6.01	3.08	1.95	4.16	2.65	1.57	4.16	2.65	1.57
	20	9.20	2.98	3.09	9.20	2.98	3.09	7.01	3.22	2.18	5.85	3.32	1.76	4.21	2.95	1.43	4.21	2.95	1.43
	25	9.31	3.18	2.93	9.31	3.18	2.93	7.15	3.42	2.09	5.97	3.53	1.69	4.30	3.08	1.40	4.30	3.08	1.40
30	/	/	/	/	/	/	/	/	/	/	/	/	/	/	/	/	/	/	
35	/	/	/	/	/	/	/	/	/	/	/	/	/	/	/	/	/	/	
75	-25	/	/	/	/	/	/	/	/	/	/	/	/	/	/	/	/	/	/
	-20	/	/	/	/	/	/	/	/	/	/	/	/	/	/	/	/	/	/
	-15	5.90	1.42	4.15	5.90	1.42	4.15	5.90	1.42	4.15	3.38	1.54	2.19	3.38	1.24	2.73	3.38	1.24	2.73
	-10	6.98	1.69	4.13	6.98	1.69	4.13	6.25	1.74	3.59	4.07	1.81	2.25	4.07	1.30	3.13	4.07	1.30	3.13
	-7	7.31	1.77	4.13	7.31	1.77	4.13	6.39	1.84	3.47	4.39	1.95	2.25	4.39	1.35	3.25	4.39	1.35	3.25
	-5	7.64	1.82	4.20	7.64	1.82	4.20	6.51	1.90	3.43	4.56	1.98	2.31	4.56	1.40	3.26	4.56	1.40	3.26
	-2	7.80	1.87	4.17	7.80	1.87	4.17	6.57	2.00	3.28	4.70	2.12	2.22	2.55	1.60	1.59	2.55	1.60	1.59
	0	7.84	1.90	4.13	7.84	1.90	4.13	6.65	2.02	3.29	4.77	2.17	2.20	2.69	1.72	1.57	2.69	1.72	1.57
	2	7.96	1.94	4.10	7.96	1.94	4.10	6.74	2.08	3.24	5.02	2.23	2.25	2.80	1.81	1.55	2.80	1.81	1.55
	5	8.10	2.00	4.05	8.10	2.00	4.05	6.82	2.13	3.20	5.42	2.28	2.38	3.27	2.00	1.64	3.27	2.00	1.64
	7	8.22	2.07	3.97	8.22	2.07	3.97	6.95	2.15	3.23	5.76	2.32	2.48	3.35	2.06	1.62	3.35	2.06	1.62
	10	8.35	2.20	3.80	8.35	2.20	3.80	6.99	2.31	3.03	5.88	2.47	2.38	3.54	2.13	1.66	3.54	2.13	1.66
	12	8.51	2.35	3.62	8.51	2.35	3.62	7.06	2.50	2.82	6.00	2.63	2.28	3.70	2.28	1.62	3.70	2.28	1.62
	15	8.18	2.52	3.25	8.18	2.52	3.25	6.98	2.68	2.60	5.74	2.82	2.04	3.93	2.49	1.58	3.93	2.49	1.58
	20	7.90	2.76	2.86	7.90	2.76	2.86	6.88	2.91	2.37	5.56	3.04	1.83	4.18	2.72	1.54	4.18	2.72	1.54
	25	/	/	/	/	/	/	/	/	/	/	/	/	/	/	/	/	/	/
30	/	/	/	/	/	/	/	/	/	/	/	/	/	/	/	/	/	/	
35	/	/	/	/	/	/	/	/	/	/	/	/	/	/	/	/	/	/	
80	-25	/	/	/	/	/	/	/	/	/	/	/	/	/	/	/	/	/	/
	-20	/	/	/	/	/	/	/	/	/	/	/	/	/	/	/	/	/	/
	-15	/	/	/	/	/	/	/	/	/	/	/	/	/	/	/	/	/	/
	-10	5.95	1.47	4.05	5.95	1.47	4.05	5.95	1.47	4.05	3.80	1.56	2.44	3.80	1.20	3.17	3.80	1.20	3.17
	-7	6.12	1.53	4.00	6.12	1.53	4.00	6.12	1.53	4.00	4.02	1.62	2.48	4.02	1.25	3.22	4.02	1.25	3.22
	-5	6.21	1.61	3.86	6.21	1.61	3.86	6.21	1.61	3.86	4.21	1.70	2.48	4.21	1.30	3.24	4.21	1.30	3.24
	-2	6.34	1.65	3.84	6.34	1.65	3.84	6.34	1.65	3.84	4.35	1.78	2.44	4.35	1.45	1.62	4.35	1.45	1.62
	0	6.52	1.69	3.86	6.52	1.69	3.86	6.52	1.69	3.86	4.52	1.84	2.46	2.50	1.57	1.59	2.50	1.57	1.59
	2	6.61	1.73	3.82	6.61	1.73	3.82	6.61	1.73	3.82	4.68	1.90	2.46	2.60	1.65	1.58	2.60	1.65	1.58
	5	6.82	1.80	3.79	6.82	1.80	3.79	6.69	1.85	3.62	4.87	1.98	2.46	3.19	1.85	1.72	3.19	1.85	1.72
	7	7.09	1.84	3.85	7.09	1.84	3.85	6.82	1.91	3.57	4.94	2.02	2.45	3.22	1.90	1.69	3.22	1.90	1.69
	10	7.16	1.98	3.62	7.16	1.98	3.62	6.86	2.02	3.41	5.05	2.12	2.38	3.37	1.93	1.74	3.37	1.93	1.74
	12	7.30	2.03	3.60	7.30	2.03	3.60	6.92	2.09	3.31	5.14	2.19	2.35	3.50	2.10	1.67	3.50	2.10	1.67
	15	7.11	2.10	3.39	7.11	2.10	3.39	6.80	2.18	3.12	4.99	2.26	2.21	3.71	2.32	1.60	3.71	2.32	1.60
	20	/	/	/	/	/	/	/	/	/	/	/	/	/	/	/	/	/	/
	25	/	/	/	/	/	/	/	/	/	/	/	/	/	/	/	/	/	/
30	/	/	/	/	/	/	/	/	/	/	/	/	/	/	/	/	/	/	
35	/	/	/	/	/	/	/	/	/	/	/	/	/	/	/	/	/	/	

Abbreviations:

LWT: Leaving water temperature (°C)

DB: Dry-bulb temperature for outdoor air temperature (°C)

HC: Total heating capacity (kW)

PI: Power input (kW)

Table 2-6.3: 12kW heating capacity

LWT	DB	Maximum			100% (Normal)			75%			50%			25%			Minimum		
		HC	COP	PI	HC	COP	PI	HC	COP	PI	HC	COP	PI	HC	COP	PI	HC	COP	PI
25	-25	8.60	2.20	3.91	8.60	2.20	3.91	7.46	2.35	3.17	4.95	2.70	1.83	2.91	2.88	1.01	2.91	2.88	1.01
	-20	10.03	2.61	3.84	10.03	2.61	3.84	7.43	2.78	2.67	4.94	3.05	1.62	3.61	3.40	1.06	3.61	3.40	1.06
	-15	11.65	2.83	4.12	10.08	2.99	3.37	7.67	3.25	2.36	5.08	3.53	1.44	4.36	3.96	1.10	4.36	3.96	1.10
	-10	13.04	3.10	4.21	9.99	3.24	3.08	7.42	3.75	1.98	5.08	4.10	1.24	5.08	4.10	1.24	5.08	4.10	1.24
	-7	13.77	3.31	4.16	10.09	3.54	2.85	7.39	4.12	1.79	5.60	4.51	1.24	5.60	4.51	1.24	5.60	4.51	1.24
	-5	14.21	3.58	3.97	9.68	3.87	2.50	7.40	4.15	1.78	5.97	4.59	1.30	5.97	4.59	1.30	5.97	4.59	1.30
	-2	14.92	3.89	3.84	9.55	4.39	2.18	7.17	4.80	1.49	5.29	5.53	0.96	5.29	5.53	0.96	5.29	5.53	0.96
	0	15.33	4.13	3.71	9.46	4.71	2.01	7.11	5.13	1.39	5.63	5.91	0.95	5.63	5.91	0.95	5.63	5.91	0.95
	2	15.82	4.39	3.60	9.22	5.04	1.83	6.86	5.45	1.26	5.97	6.16	0.97	5.97	6.16	0.97	5.97	6.16	0.97
	5	16.24	5.12	3.17	10.88	6.01	1.81	8.07	6.43	1.26	6.10	6.73	0.91	5.50	6.80	0.81	5.50	6.80	0.81
	7	16.67	5.41	3.08	11.96	6.24	1.92	8.95	7.09	1.26	6.00	7.30	0.82	5.60	7.30	0.77	5.60	7.30	0.77
	10	17.16	6.73	2.55	12.10	7.30	1.66	9.13	7.80	1.17	6.30	8.10	0.78	5.90	8.25	0.72	5.90	8.25	0.72
	12	17.57	7.44	2.36	12.07	8.12	1.49	9.01	8.65	1.04	6.50	8.90	0.73	6.00	8.80	0.68	6.00	8.80	0.68
	15	16.58	7.85	2.11	12.10	8.85	1.37	8.89	9.60	0.93	5.94	9.90	0.60	6.20	9.10	0.68	6.20	9.10	0.68
	20	15.77	8.72	1.81	12.01	9.87	1.22	9.04	10.38	0.87	5.98	11.08	0.54	6.40	9.50	0.67	6.40	9.50	0.67
	25	15.72	9.51	1.65	11.94	10.70	1.12	8.81	11.65	0.76	6.30	12.20	0.52	6.55	11.10	0.59	6.55	11.10	0.59
30	/	/	/	/	/	/	/	/	/	/	/	/	/	/	/	/	/	/	/
35	/	/	/	/	/	/	/	/	/	/	/	/	/	/	/	/	/	/	/
30	-25	8.43	2.08	4.05	8.43	2.08	4.05	7.48	2.16	3.46	4.94	2.38	2.08	2.85	2.52	1.13	2.85	2.52	1.13
	-20	9.87	2.25	4.39	9.87	2.25	4.39	7.40	2.55	2.90	4.90	2.78	1.76	3.54	2.93	1.21	3.54	2.93	1.21
	-15	11.48	2.58	4.45	10.06	2.76	3.64	7.46	3.00	2.49	4.93	3.22	1.53	4.28	3.45	1.24	4.28	3.45	1.24
	-10	12.84	2.86	4.49	10.09	2.97	3.40	7.47	3.42	2.18	4.99	3.57	1.40	4.99	3.57	1.40	4.99	3.57	1.40
	-7	13.55	3.05	4.44	10.06	3.23	3.12	7.42	3.74	1.98	5.50	4.15	1.33	5.50	4.15	1.33	5.50	4.15	1.33
	-5	13.98	3.30	4.24	9.75	3.51	2.78	7.43	3.97	1.87	5.87	4.28	1.37	5.87	4.28	1.37	5.87	4.28	1.37
	-2	14.70	3.58	4.11	9.64	3.94	2.45	7.26	4.41	1.65	5.20	4.92	1.06	5.20	4.92	1.06	5.20	4.92	1.06
	0	15.11	3.80	3.98	9.32	4.24	2.20	7.14	4.70	1.52	5.54	5.25	1.05	5.54	5.25	1.06	5.54	5.25	1.06
	2	15.58	4.02	3.88	9.25	4.50	2.05	6.91	5.03	1.37	5.87	5.43	1.08	5.87	5.43	1.08	5.87	5.43	1.08
	5	16.02	4.44	3.61	10.93	5.24	2.08	8.12	5.70	1.42	6.00	6.25	0.96	5.15	6.50	0.79	5.15	6.50	0.79
	7	16.44	4.77	3.45	11.99	5.54	2.16	8.99	6.14	1.46	5.50	7.00	0.79	5.20	6.80	0.76	5.20	6.80	0.76
	10	16.91	5.73	2.95	12.15	6.65	1.83	8.98	7.23	1.24	5.90	7.86	0.75	5.50	7.30	0.75	5.50	7.30	0.75
	12	17.29	6.25	2.77	11.87	7.35	1.61	9.07	7.83	1.16	6.00	8.50	0.71	5.80	8.00	0.73	5.80	8.00	0.73
	15	16.32	6.57	2.48	11.92	7.55	1.58	9.02	8.30	1.09	6.34	9.00	0.70	6.40	8.30	0.77	6.40	8.30	0.77
	20	15.52	6.90	2.25	12.04	8.15	1.48	8.91	9.11	0.98	5.98	9.75	0.61	6.50	8.60	0.76	6.50	8.60	0.76
	25	15.48	8.03	1.93	12.18	9.09	1.34	9.16	9.68	0.95	6.69	10.35	0.65	6.80	9.00	0.76	6.80	9.00	0.76
30	15.61	9.61	1.62	11.89	10.38	1.15	9.22	11.15	0.83	7.33	11.60	0.63	7.40	9.50	0.78	7.40	9.50	0.78	
35	/	/	/	/	/	/	/	/	/	/	/	/	/	/	/	/	/	/	/
35	-25	8.26	1.90	4.35	8.26	1.90	4.35	7.40	1.98	3.73	4.95	2.18	2.27	2.71	2.40	1.13	2.71	2.40	1.13
	-20	9.72	2.20	4.42	9.72	2.20	4.42	7.39	2.37	3.12	4.91	2.58	1.90	3.43	2.79	1.23	3.43	2.79	1.23
	-15	11.33	2.32	4.88	9.93	2.58	3.85	7.44	2.78	2.68	4.85	2.98	1.63	4.18	3.12	1.34	4.18	3.12	1.34
	-10	11.85	2.66	4.45	10.19	2.74	3.72	7.47	3.13	2.38	4.85	3.48	1.39	4.85	3.48	1.39	4.85	3.48	1.39
	-7	12.36	2.83	4.37	10.00	3.15	3.17	7.45	3.42	2.18	5.36	3.69	1.45	5.36	3.69	1.45	5.36	3.69	1.45
	-5	12.76	3.06	4.17	9.80	3.29	2.98	7.29	3.56	2.05	5.71	3.72	1.53	5.71	3.72	1.53	5.71	3.72	1.53
	-2	13.41	3.32	4.04	9.72	3.55	2.73	7.30	3.95	1.85	5.06	4.38	1.16	5.06	4.38	1.16	5.06	4.38	1.16
	0	13.78	3.61	3.82	9.33	3.84	2.43	7.16	4.30	1.67	5.39	4.67	1.15	5.39	4.67	1.15	5.39	4.67	1.15
	2	14.30	3.84	3.72	9.20	4.00	2.30	7.07	4.52	1.56	5.76	4.84	1.19	5.76	4.84	1.19	5.76	4.84	1.19
	5	14.60	4.13	3.54	10.95	4.59	2.39	8.16	4.90	1.67	5.89	5.12	1.15	5.20	5.52	0.94	5.20	5.52	0.94
	7	14.97	4.48	3.34	12.10	4.95	2.44	9.01	5.27	1.72	5.34	5.65	0.95	5.30	5.70	0.93	5.30	5.70	0.93
	10	16.62	4.84	3.43	11.95	5.53	2.16	9.03	5.99	1.51	5.60	6.39	0.88	5.50	6.20	0.89	5.50	6.20	0.89
	12	16.99	5.24	3.24	12.17	5.89	2.07	8.91	6.27	1.42	5.94	6.69	0.89	5.65	6.90	0.82	5.65	6.90	0.82
	15	16.07	5.50	2.92	11.92	6.35	1.88	9.05	6.93	1.31	6.64	7.40	0.90	5.85	7.40	0.79	5.85	7.40	0.79
	20	15.25	6.38	2.39	12.05	7.12	1.69	9.00	7.78	1.16	6.19	8.35	0.74	6.19	8.00	0.77	6.19	8.00	0.77
	25	15.20	7.25	2.10	12.02	7.81	1.54	9.34	8.56	1.09	6.90	8.61	0.80	6.70	8.60	0.78	6.70	8.60	0.78
30	15.34	8.24	1.86	12.18	8.99	1.36	9.15	9.28	0.99	7.54	9.42	0.80	6.85	9.00	0.76	6.85	9.00	0.76	
35	15.01	10.15	1.48	12.21	10.43	1.17	9.09	10.72	0.85	8.23	10.86	0.76	7.20	9.30	0.77	7.20	9.30	0.77	
40	-25	8.10	1.82	4.45	8.10	1.82	4.45	7.80	1.85	4.22	5.23	2.07	2.53	2.81	2.31	1.22	2.81	2.31	1.22
	-20	9.55	2.06	4.64	9.55	2.06	4.63	7.82	2.18	3.58	5.13	2.54	2.02	3.56	2.70	1.32	3.56	2.70	1.32
	-15	11.17	2.28	4.90	10.40	2.37	4.39	7.78	2.55	3.05	5.13	2.76	1.86	4.33	2.80	1.55	4.33	2.80	1.55
	-10	12.43	2.48	5.01	10.79	2.55	4.23	7.80	2.86	2.73	5.01	3.18	1.58	5.01	3.18	1.58	5.01	3.18	1.58
	-7	13.14	2.70	4.87	10.44	2.72	3.84	7.74	3.12	2.48	5.53	3.46	1.60	5.53	3.46	1.60	5.53	3.46	1.60
	-5	13.56	2.84	4.77	10.42	2.89	3.60	7.60	3.12	2.43	5.91	3.59	1.65	5.91	3.59	1.65	5.91	3.59	1.65
	-2	14.28	3.08	4.64	10.40	3.15	3.30	7.79	3.37	2.31	5.90	3.76	1.57	5.00	3.79	1.32	5.00	3.79	1.32
	0	14.66	3.25	4.51	10.49	3.34	3.14	7.89	3.55	2.22	6.28	3.98	1.58	5.30	3.98	1.33	5.30	3.98	1.33
	2	15.12	3.43	4.41	10.28	3.59	2.87	7.73	3.84	2.01	6.65	4.12	1.61	5.65	4.11	1.38	5.65	4.11	1.38
	5	15.66	3.73	4.20	11.42	4.22	2.71	8.52	4.46	1.91	7.22	4.58	1.58	4.29	4.71	0.91	4.29	4.71	0.91
	7	15.85	4.10	3.87	12.17	4.40	2.77	9.11	4.83	1.89	7.58	4.95	1.53	4.48	4.68	0.96	4.48	4.68	0.96
	10	16.33	4.40	3.71	12.17	4.90	2.48	9.05	5.40	1.68	7.94	5.46	1.45	4.77	5.03	0.95	4.77	5.03	0.95
	12	16.69	4.73	3.53	12.16	5.21	2.33	9.15	5.74	1.59	8.41	5.80	1.45	4.96	5.38	0.92	4.96	5.38	0.92
	15	15.78	4.91	3.21	12.11	5.60	2.16	9.05	6.23	1.45	8.21	6.56	1.25	5.25	5.76	0.91	5.25	5.76	0.91
	20	14.98	5.60	2.68	12.04	6.00	2.01	8.98	6.57	1.37	7.09	6.90	1.03	5.73	6.18	0.93	5.73	6.18	0.93
	25	14.92	6.11	2.44															

R290 M thermal Nature Plus Series



Table 2-6.3: 12kW heating capacity (continued)

LWT	DB	Maximum			100% (Normal)			75%			50%			25%			Minimum		
		HC	COP	PI	HC	COP	PI	HC	COP	PI	HC	COP	PI	HC	COP	PI	HC	COP	PI
45	-25	5.48	1.77	3.10	5.48	1.77	3.10	5.48	1.77	3.10	3.99	1.85	2.16	2.11	1.96	1.08	2.11	1.96	1.08
	-20	6.65	2.12	3.14	6.65	2.12	3.14	6.09	2.14	2.85	4.02	2.25	1.79	2.68	2.31	1.16	2.68	2.31	1.16
	-15	7.72	2.22	3.48	7.72	2.22	3.48	6.15	2.36	2.61	4.03	2.48	1.63	3.19	2.52	1.27	3.19	2.52	1.27
	-10	8.60	2.42	3.55	7.97	2.48	3.21	5.95	2.60	2.29	4.05	2.70	1.50	3.80	2.72	1.40	3.80	2.72	1.40
	-7	9.29	2.46	3.78	8.00	2.60	3.08	6.00	2.72	2.21	4.30	2.91	1.48	4.30	2.91	1.48	4.30	2.91	1.48
	-5	9.80	2.55	3.84	7.95	2.69	2.96	6.02	2.90	2.08	4.56	3.05	1.50	4.56	3.05	1.50	4.56	3.05	1.50
	-2	10.50	2.69	3.90	8.06	2.87	2.81	6.03	3.08	1.96	4.63	3.20	1.45	3.65	3.25	1.12	3.65	3.25	1.12
	0	10.61	2.76	3.84	8.07	2.96	2.73	5.91	3.15	1.88	4.71	3.36	1.40	3.80	3.40	1.12	3.80	3.40	1.12
	2	10.97	2.86	3.84	8.00	3.15	2.54	5.94	3.35	1.77	5.07	3.57	1.42	3.90	3.65	1.07	3.90	3.65	1.07
	5	10.81	3.19	3.39	8.02	3.65	2.20	6.04	3.90	1.55	5.14	4.14	1.24	3.34	3.48	0.96	3.34	3.48	0.96
	7	11.03	3.50	3.15	8.10	4.00	2.02	6.08	4.31	1.41	5.69	4.53	1.26	3.52	3.64	0.97	3.52	3.64	0.97
	10	11.24	4.00	2.81	7.98	4.61	1.73	5.99	4.91	1.22	5.83	5.07	1.15	3.79	3.86	0.98	3.79	3.86	0.98
	12	11.58	4.31	2.69	8.00	4.92	1.63	6.25	5.26	1.19	6.25	5.26	1.19	3.97	3.96	1.00	3.97	3.96	1.00
	15	10.31	4.76	2.17	8.02	5.20	1.54	6.20	5.61	1.11	6.20	5.61	1.11	4.24	4.13	1.03	4.24	4.13	1.03
	20	9.70	5.41	1.79	8.02	5.80	1.38	6.09	6.11	1.00	6.09	6.11	1.00	4.68	4.37	1.07	4.68	4.37	1.07
25	10.03	5.91	1.70	8.20	6.47	1.27	6.06	6.86	0.88	6.06	6.86	0.88	5.13	4.50	1.14	5.13	4.50	1.14	
30	10.43	6.58	1.59	8.13	7.20	1.13	6.69	7.72	0.87	6.69	7.72	0.87	5.58	4.64	1.20	5.58	4.64	1.20	
35	10.69	7.24	1.48	8.13	8.21	0.99	7.36	8.81	0.84	7.36	8.81	0.84	6.03	5.90	1.02	6.03	5.90	1.02	
50	-25	5.30	1.64	3.23	5.30	1.64	3.23	5.30	1.64	3.23	3.84	1.80	2.13	2.15	1.70	1.26	2.15	1.70	1.26
	-20	6.52	1.92	3.40	6.52	1.92	3.40	5.93	1.98	2.99	3.87	2.08	1.86	2.76	1.80	1.53	2.76	1.80	1.53
	-15	7.44	2.03	3.67	7.44	2.03	3.67	5.98	2.18	2.74	3.88	2.35	1.65	3.25	1.92	1.69	3.25	1.92	1.69
	-10	8.43	2.24	3.76	7.69	2.30	3.34	5.80	2.46	2.36	3.88	2.64	1.47	3.88	2.00	1.94	3.88	2.00	1.94
	-7	8.94	2.34	3.82	7.68	2.45	3.13	5.80	2.54	2.28	4.19	2.74	1.53	4.19	2.15	1.95	4.19	2.15	1.95
	-5	9.43	2.51	3.76	7.72	2.58	2.99	5.79	2.70	2.14	4.62	2.80	1.65	4.62	2.30	2.01	4.62	2.30	2.01
	-2	9.81	2.60	3.77	7.90	2.78	2.84	5.95	2.90	2.05	4.90	2.96	1.66	3.30	2.78	1.19	3.30	2.78	1.19
	0	10.18	2.73	3.73	7.97	2.89	2.76	5.88	2.95	1.99	5.05	3.01	1.68	3.53	2.90	1.22	3.53	2.90	1.22
	2	10.51	2.80	3.75	7.88	2.97	2.65	6.07	3.11	1.95	5.41	3.21	1.69	3.76	3.08	1.22	3.76	3.08	1.22
	5	10.58	3.02	3.50	7.97	3.25	2.45	6.11	3.43	1.78	5.82	3.45	1.69	3.21	3.12	1.03	3.21	3.12	1.03
	7	10.78	3.22	3.35	8.13	3.54	2.30	6.26	3.76	1.66	6.26	3.76	1.66	3.38	3.26	1.04	3.38	3.26	1.04
	10	10.95	3.51	3.12	8.03	3.87	2.07	6.45	4.07	1.58	6.45	4.07	1.59	3.64	3.46	1.05	3.64	3.46	1.05
	12	11.13	3.85	2.89	8.09	4.11	1.97	6.50	4.33	1.50	6.50	4.33	1.50	3.82	3.58	1.07	3.82	3.58	1.07
	15	10.05	4.19	2.40	7.97	4.42	1.80	6.65	4.67	1.42	6.65	4.67	1.42	4.08	3.76	1.09	4.08	3.76	1.09
	20	9.42	4.73	1.99	8.01	4.98	1.61	6.42	5.26	1.22	6.42	5.26	1.22	4.51	4.03	1.12	4.51	4.03	1.12
25	9.74	5.23	1.86	7.95	5.51	1.44	6.28	5.90	1.06	6.28	5.90	1.06	4.95	4.26	1.16	4.95	4.26	1.16	
30	10.14	5.79	1.75	8.13	6.11	1.33	6.92	6.45	1.07	6.92	6.45	1.07	5.38	4.49	1.20	5.38	4.49	1.20	
35	10.42	6.40	1.63	8.11	6.88	1.18	7.61	7.16	1.06	7.61	7.16	1.06	5.82	5.28	1.10	5.82	5.28	1.10	
55	-25	5.14	1.55	3.32	5.14	1.55	3.32	5.14	1.55	3.32	3.83	1.63	2.35	2.45	1.78	1.38	2.45	1.78	1.38
	-20	6.28	1.86	3.38	6.28	1.86	3.38	5.49	1.94	2.83	3.78	2.00	1.89	3.13	1.85	1.69	3.13	1.85	1.69
	-15	7.05	1.96	3.60	7.05	1.96	3.60	5.54	2.09	2.65	3.92	2.14	1.83	3.64	1.90	1.92	3.64	1.90	1.92
	-10	8.01	2.11	3.80	7.55	2.16	3.50	5.61	2.29	2.45	4.33	2.38	1.82	4.33	1.95	2.22	4.33	1.95	2.22
	-7	8.45	2.23	3.79	7.50	2.30	3.26	5.70	2.38	2.39	4.86	2.47	1.97	4.86	2.02	2.41	4.86	2.02	2.41
	-5	8.71	2.26	3.85	7.64	2.41	3.17	5.78	2.51	2.30	5.26	2.60	2.02	5.26	2.10	2.50	5.26	2.10	2.50
	-2	8.97	2.30	3.90	7.78	2.54	3.06	5.91	2.65	2.23	5.46	2.71	2.01	3.11	2.30	1.35	3.11	2.30	1.35
	0	9.10	2.44	3.73	7.79	2.63	2.96	5.93	2.71	2.19	5.57	2.80	1.99	3.45	2.40	1.44	3.45	2.40	1.44
	2	9.27	2.52	3.68	8.00	2.70	2.96	6.10	2.80	2.18	5.85	2.87	2.04	3.84	2.50	1.54	3.84	2.50	1.54
	5	10.04	2.91	3.45	7.97	3.11	2.56	6.24	3.16	1.97	6.12	3.26	1.88	3.30	2.75	1.20	3.30	2.75	1.20
	7	10.49	3.04	3.45	8.00	3.35	2.39	6.35	3.51	1.81	6.35	3.51	1.81	3.48	2.88	1.21	3.48	2.88	1.21
	10	10.71	3.32	3.23	8.10	3.65	2.22	6.41	3.86	1.66	6.41	3.86	1.66	3.75	3.07	1.22	3.75	3.07	1.22
	12	10.84	3.54	3.06	8.17	3.78	2.16	6.53	4.04	1.62	6.53	4.04	1.62	3.93	3.19	1.23	3.93	3.19	1.23
	15	9.93	3.74	2.66	8.00	4.01	2.00	6.35	4.23	1.50	6.35	4.23	1.50	4.20	3.38	1.24	4.20	3.38	1.24
	20	9.29	4.23	2.20	8.06	4.43	1.82	6.26	4.62	1.35	6.26	4.62	1.35	4.65	3.70	1.26	4.65	3.70	1.26
25	9.62	4.59	2.10	8.12	4.87	1.67	6.64	5.08	1.31	6.64	5.08	1.31	5.10	4.02	1.27	5.10	4.02	1.27	
30	10.01	5.02	1.99	8.06	5.42	1.49	7.31	5.60	1.31	7.31	5.60	1.31	5.55	4.33	1.28	5.55	4.33	1.28	
35	10.25	5.54	1.85	8.03	6.05	1.33	8.03	6.05	1.33	8.03	6.05	1.33	6.00	4.65	1.29	6.00	4.65	1.29	
60	-25	4.87	1.26	3.87	4.87	1.26	3.87	4.87	1.26	3.87	3.74	1.44	2.60	2.59	1.60	1.62	2.59	1.60	1.62
	-20	6.00	1.55	3.87	6.00	1.55	3.87	5.45	1.60	3.41	3.74	1.76	2.12	3.30	1.67	1.98	3.30	1.67	1.98
	-15	6.57	1.71	3.84	6.57	1.71	3.84	5.61	1.84	3.05	4.01	1.92	2.09	3.81	1.70	2.24	3.81	1.70	2.24
	-10	7.56	2.00	3.78	7.56	2.00	3.78	5.66	2.15	2.63	4.50	2.23	2.02	4.50	1.75	2.57	4.50	1.75	2.57
	-7	8.22	2.12	3.88	7.57	2.23	3.39	5.68	2.32	2.45	4.91	2.40	2.05	4.91	1.80	2.73	4.91	1.80	2.73
	-5	8.47	2.24	3.78	7.60	2.30	3.30	5.71	2.41	2.37	5.16	2.46	2.10	5.16	1.85	2.79	5.16	1.85	2.79
	-2	8.61	2.30	3.74	7.71	2.42	3.19	5.81	2.53	2.30	5.42	2.59	2.09	3.14	2.05	1.53	3.14	2.05	1.53
	0	8.70	2.34	3.72	7.81	2.46	3.17	5.88	2.62	2.24	5.56	2.66	2.09	3.27	2.15	1.52	3.27	2.15	1.52
	2	8.89	2.39	3.72	7.96	2.51	3.17	5.98	2.68	2.23	5.81	2.72	2.14	3.40	2.27	1.50	3.40	2.27	1.50
	5	9.75	2.62	3.72	7.95	2.76	2.88	6.16	2.92	2.11	6.16	2.92	2.11	3.51	2.45	1.43	3.51	2.45	1.43
	7	10.27	2.74	3.75	7.94	3.00	2.65	6.34	3.18	1.99	6.34	3.18	1.99	3.73	2.56	1.46	3.73	2.56	1.46
	10	10.46	2.94	3.56	7.94	3.20	2.48	6.48	3.48	1.86	6.48	3.48	1.86	4.06	2.72	1.49	4.06	2.72	1.49
	12	10.60	3.15	3.37	7.96	3.39	2.35	6.69	3.65	1.83	6.69	3.65	1.83	4.28	2.82	1.52	4.28	2.82	1.52
	15	9.72	3.40	2.86	7.96	3.60	2.21	6.56	3.84	1.71	6.56	3.84	1.71	4.61	2.98	1.54	4.61	2.98	1.54
	20	9.05	3.76	2.41	8.02	3.94	2.04	6.32	4.16	1.52	6.32								

Table 2-6.3: 12kW heating capacity (continued)

LWT	DB	Maximum			100% (Normal)			75%			50%			25%			Minimum		
		HC	COP	PI	HC	COP	PI	HC	COP	PI	HC	COP	PI	HC	COP	PI	HC	COP	PI
65	-25	/	/	/	/	/	/	/	/	/	/	/	/	/	/	/	/	/	/
	-20	5.62	1.46	3.85	5.62	1.46	3.85	5.42	1.47	3.69	3.75	1.50	2.50	3.20	1.54	2.08	3.20	1.54	2.08
	-15	6.16	1.63	3.78	6.16	1.63	3.78	5.59	1.65	3.39	3.89	1.84	2.11	3.69	1.60	2.31	3.69	1.60	2.31
	-10	7.30	1.89	3.86	7.15	1.90	3.76	5.60	1.94	2.89	4.35	2.10	2.07	4.35	1.65	2.64	4.35	1.65	2.64
	-7	7.83	2.04	3.84	7.37	2.05	3.60	5.58	2.14	2.61	4.90	2.21	2.22	4.90	1.70	2.88	4.90	1.70	2.88
	-5	8.15	2.12	3.84	7.48	2.18	3.43	5.67	2.27	2.50	5.12	2.34	2.19	5.12	1.73	2.96	5.12	1.73	2.96
	-2	8.28	2.18	3.80	7.81	2.24	3.49	5.83	2.33	2.50	5.25	2.42	2.17	2.94	1.90	1.55	2.94	1.90	1.55
	0	8.31	2.25	3.69	7.84	2.32	3.38	5.86	2.40	2.44	5.41	2.46	2.20	3.08	2.01	1.53	3.08	2.01	1.53
	2	8.42	2.29	3.68	7.92	2.35	3.37	5.95	2.43	2.45	5.60	2.50	2.24	3.20	2.12	1.51	3.20	2.12	1.51
	5	9.02	2.50	3.61	7.93	2.57	3.09	5.89	2.65	2.22	5.89	2.65	2.22	3.43	2.30	1.49	3.43	2.30	1.49
	7	9.85	2.70	3.65	7.99	2.75	2.91	6.07	2.89	2.10	6.07	2.89	2.10	3.60	2.39	1.51	3.60	2.39	1.51
	10	9.65	2.81	3.43	8.01	2.98	2.69	6.25	3.08	2.03	6.25	3.08	2.03	3.89	2.52	1.54	3.89	2.52	1.54
	12	9.88	2.92	3.38	8.17	3.12	2.62	6.46	3.25	1.99	6.46	3.25	1.99	4.09	2.64	1.55	4.09	2.64	1.55
	15	9.52	3.11	3.06	7.94	3.27	2.43	6.32	3.38	1.87	6.32	3.38	1.87	4.38	2.82	1.56	4.38	2.82	1.56
	20	8.79	3.42	2.57	7.96	3.52	2.26	6.01	3.65	1.65	6.01	3.65	1.65	4.50	3.10	1.45	4.50	3.10	1.45
	25	8.99	3.70	2.43	7.91	3.84	2.06	6.23	3.94	1.58	6.23	3.94	1.58	4.65	3.29	1.41	4.65	3.29	1.41
30	9.23	3.94	2.34	7.96	4.05	1.97	6.59	4.16	1.58	6.59	4.16	1.58	4.72	3.49	1.35	4.72	3.49	1.35	
35	/	/	/	/	/	/	/	/	/	/	/	/	/	/	/	/	/	/	
70	-25	/	/	/	/	/	/	/	/	/	/	/	/	/	/	/	/	/	/
	-20	5.33	1.37	3.89	5.33	1.37	3.89	5.33	1.37	3.89	3.82	1.45	2.63	3.18	1.40	2.27	3.18	1.40	2.27
	-15	6.01	1.58	3.80	6.01	1.58	3.80	5.49	1.62	3.39	3.84	1.70	2.26	3.66	1.45	2.52	3.66	1.45	2.52
	-10	6.88	1.80	3.82	6.88	1.80	3.82	5.60	1.87	2.99	4.31	1.93	2.23	4.31	1.50	2.87	4.31	1.50	2.87
	-7	7.32	1.96	3.73	7.32	1.96	3.73	5.57	2.09	2.67	4.66	2.15	2.17	4.66	1.55	3.01	4.66	1.55	3.01
	-5	7.50	2.08	3.61	7.50	2.08	3.61	5.68	2.18	2.61	4.81	2.24	2.15	4.81	1.60	3.01	4.81	1.60	3.01
	-2	7.67	2.12	3.62	7.67	2.12	3.62	5.88	2.23	2.64	4.91	2.29	2.14	2.74	1.75	1.57	2.74	1.75	1.57
	0	7.80	2.15	3.63	7.80	2.15	3.63	5.86	2.27	2.58	5.02	2.35	2.14	2.89	1.86	1.55	2.89	1.86	1.55
	2	7.94	2.17	3.66	7.94	2.17	3.66	5.91	2.31	2.56	5.23	2.40	2.18	3.00	1.96	1.53	3.00	1.96	1.53
	5	8.22	2.35	3.50	7.96	2.41	3.30	5.99	2.52	2.38	5.64	2.58	2.19	3.35	2.15	1.56	3.35	2.15	1.56
	7	8.56	2.43	3.52	8.01	2.52	3.18	6.05	2.65	2.28	6.05	2.65	2.28	3.48	2.23	1.56	3.48	2.23	1.56
	10	8.90	2.62	3.40	8.03	2.71	2.96	6.15	2.82	2.18	6.15	2.82	2.18	3.71	2.32	1.60	3.71	2.32	1.60
	12	9.08	2.71	3.35	8.07	2.83	2.85	6.27	2.96	2.12	6.27	2.96	2.12	3.89	2.46	1.58	3.89	2.46	1.58
	15	8.83	2.85	3.10	8.01	2.96	2.71	6.01	3.08	1.95	6.01	3.08	1.95	4.16	2.65	1.57	4.16	2.65	1.57
	20	8.58	3.10	2.77	8.06	3.18	2.53	5.85	3.32	1.76	5.85	3.32	1.76	4.21	2.95	1.43	4.21	2.95	1.43
	25	8.68	3.28	2.65	8.16	3.37	2.42	5.97	3.53	1.69	5.97	3.53	1.69	4.30	3.08	1.40	4.30	3.08	1.40
30	/	/	/	/	/	/	/	/	/	/	/	/	/	/	/	/	/	/	
35	/	/	/	/	/	/	/	/	/	/	/	/	/	/	/	/	/	/	
75	-25	/	/	/	/	/	/	/	/	/	/	/	/	/	/	/	/	/	/
	-20	/	/	/	/	/	/	/	/	/	/	/	/	/	/	/	/	/	/
	-15	5.54	1.44	3.85	5.54	1.44	3.85	5.40	1.46	3.70	3.38	1.54	2.19	3.38	1.24	2.73	3.38	1.24	2.73
	-10	6.16	1.75	3.52	6.16	1.75	3.52	5.41	1.80	3.01	4.07	1.81	2.25	4.07	1.30	3.13	4.07	1.30	3.13
	-7	6.59	1.84	3.58	6.59	1.84	3.58	5.47	1.91	2.86	4.39	1.95	2.25	4.39	1.35	3.25	4.39	1.35	3.25
	-5	6.84	1.90	3.60	6.84	1.90	3.60	5.45	1.96	2.78	4.56	1.98	2.31	4.56	1.40	3.26	4.56	1.40	3.26
	-2	6.97	1.97	3.54	6.97	1.97	3.54	5.48	2.06	2.66	4.70	2.12	2.22	2.55	1.60	1.59	2.55	1.60	1.59
	0	7.10	2.00	3.55	7.10	2.00	3.55	5.50	2.10	2.62	4.77	2.17	2.20	2.69	1.72	1.57	2.69	1.72	1.57
	2	7.23	2.02	3.58	7.23	2.02	3.58	5.51	2.15	2.56	5.02	2.23	2.25	2.80	1.81	1.55	2.80	1.81	1.55
	5	7.65	2.09	3.66	7.65	2.09	3.66	5.56	2.20	2.53	5.42	2.28	2.38	3.27	2.00	1.64	3.27	2.00	1.64
	7	7.82	2.14	3.65	7.82	2.14	3.65	5.76	2.32	2.48	5.76	2.32	2.48	3.35	2.06	1.62	3.35	2.06	1.62
	10	7.91	2.31	3.42	7.91	2.31	3.42	5.88	2.47	2.38	5.88	2.47	2.38	3.54	2.13	1.66	3.54	2.13	1.66
	12	8.05	2.44	3.30	8.05	2.44	3.30	6.00	2.63	2.28	6.00	2.63	2.28	3.70	2.28	1.62	3.70	2.28	1.62
	15	7.90	2.60	3.04	7.90	2.60	3.04	5.74	2.82	2.04	5.74	2.82	2.04	3.93	2.49	1.58	3.93	2.49	1.58
	20	7.73	2.86	2.70	7.73	2.86	2.70	5.56	3.04	1.83	5.56	3.04	1.83	4.18	2.72	1.54	4.18	2.72	1.54
	25	/	/	/	/	/	/	/	/	/	/	/	/	/	/	/	/	/	/
30	/	/	/	/	/	/	/	/	/	/	/	/	/	/	/	/	/	/	
35	/	/	/	/	/	/	/	/	/	/	/	/	/	/	/	/	/	/	
80	-25	/	/	/	/	/	/	/	/	/	/	/	/	/	/	/	/	/	/
	-20	/	/	/	/	/	/	/	/	/	/	/	/	/	/	/	/	/	/
	-15	/	/	/	/	/	/	/	/	/	/	/	/	/	/	/	/	/	/
	-10	5.52	1.52	3.63	5.52	1.52	3.63	5.16	1.54	3.35	3.80	1.56	2.44	3.80	1.20	3.17	3.80	1.20	3.17
	-7	5.84	1.55	3.77	5.84	1.55	3.77	5.23	1.60	3.27	4.02	1.62	2.48	4.02	1.25	3.22	4.02	1.25	3.22
	-5	5.97	1.62	3.69	5.97	1.62	3.69	5.26	1.66	3.17	4.21	1.70	2.48	4.21	1.30	3.24	4.21	1.30	3.24
	-2	6.04	1.68	3.60	6.04	1.68	3.60	5.29	1.73	3.06	4.35	1.78	2.44	4.35	1.45	1.62	4.35	1.45	1.62
	0	6.17	1.74	3.55	6.17	1.74	3.55	5.34	1.79	2.98	4.52	1.84	2.46	2.50	1.57	1.59	2.50	1.57	1.59
	2	6.38	1.78	3.58	6.38	1.78	3.58	5.37	1.84	2.92	4.68	1.90	2.46	2.60	1.65	1.58	2.60	1.65	1.58
	5	6.58	1.85	3.56	6.58	1.85	3.56	5.39	1.92	2.81	4.87	1.98	2.46	3.19	1.85	1.72	3.19	1.85	1.72
	7	6.81	1.91	3.57	6.81	1.91	3.57	5.42	1.96	2.77	4.94	2.02	2.45	3.22	1.90	1.69	3.22	1.90	1.69
	10	6.92	2.00	3.46	6.92	2.00	3.46	5.51	2.08	2.65	5.05	2.12	2.38	3.37	1.93	1.74	3.37	1.93	1.74
	12	7.03	2.06	3.41	7.03	2.06	3.41	5.62	2.14	2.63	5.14	2.19	2.35	3.50	2.10	1.67	3.50	2.10	1.67
	15	6.87	2.15	3.20	6.87	2.15	3.20	5.40	2.22	2.43	4.99	2.26	2.21	3.71	2.32	1.60	3.71	2.32	1.60
	20	/	/	/	/	/	/	/	/	/	/	/	/	/	/	/	/	/	/
	25	/	/	/	/	/	/	/	/	/	/	/	/	/	/	/	/	/	/
30	/	/	/	/	/	/	/	/	/	/	/	/	/	/	/	/	/	/	
35	/	/	/	/	/	/	/	/	/	/	/	/	/	/	/	/	/	/	

Abbreviations:

LWT: Leaving water temperature (°C)

DB: Dry-bulb temperature for outdoor air temperature (°C)

HC: Total heating capacity (kW)

PI: Power input (kW)

R290 M thermal Nature Plus Series



Table 2-6.4: 14kW heating capacity

LWT	DB	Maximum			100% (Normal)			75%			50%			25%			Minimum		
		HC	COP	PI	HC	COP	PI	HC	COP	PI	HC	COP	PI	HC	COP	PI	HC	COP	PI
25	-25	9.34	2.10	4.45	9.34	2.10	4.45	8.97	2.16	4.15	5.97	2.45	2.44	2.91	2.88	1.01	2.91	2.88	1.01
	-20	10.86	2.56	4.24	10.86	2.56	4.24	8.96	2.71	3.31	5.87	2.92	2.01	3.61	3.40	1.06	3.61	3.40	1.06
	-15	12.58	2.73	4.61	11.97	2.81	4.26	8.93	3.22	2.77	5.85	3.43	1.71	4.36	3.96	1.10	4.36	3.96	1.10
	-10	14.08	3.07	4.59	12.02	3.14	3.83	8.95	3.41	2.62	5.87	3.85	1.52	5.08	4.10	1.24	5.08	4.10	1.24
	-7	15.05	3.16	4.76	11.98	3.34	3.59	8.90	3.97	2.24	5.93	4.46	1.33	5.60	4.51	1.24	5.60	4.51	1.24
	-5	15.50	3.50	4.43	11.82	3.62	3.27	8.84	4.05	2.18	5.97	4.59	1.30	5.97	4.59	1.30	5.97	4.59	1.30
	-2	16.18	3.79	4.27	11.38	4.05	2.81	8.49	4.65	1.83	5.68	5.28	1.08	5.29	5.53	0.96	5.29	5.53	0.96
	0	16.70	4.00	4.18	11.18	4.40	2.54	8.46	5.00	1.69	5.63	5.91	0.95	5.63	5.91	0.95	5.63	5.91	0.95
	2	17.17	4.22	4.07	10.99	4.80	2.29	8.17	5.30	1.54	5.97	6.16	0.97	5.97	6.16	0.97	5.97	6.16	0.97
	5	17.66	4.94	3.57	12.72	5.65	2.25	9.37	6.25	1.50	6.35	6.70	0.95	5.50	6.80	0.81	5.50	6.80	0.81
	7	18.19	5.22	3.48	13.96	6.04	2.31	10.43	6.93	1.51	6.93	7.21	0.96	5.60	7.30	0.77	5.60	7.30	0.77
	10	18.61	6.35	2.93	14.10	7.05	2.00	10.38	7.70	1.35	6.30	8.10	0.78	5.90	8.25	0.72	5.90	8.25	0.72
	12	18.95	7.30	2.60	13.83	7.98	1.73	10.35	8.50	1.22	6.50	8.90	0.73	6.00	8.80	0.68	6.00	8.80	0.68
	15	17.72	7.70	2.30	13.89	8.67	1.60	10.29	9.45	1.09	6.81	9.75	0.70	6.20	9.10	0.68	6.20	9.10	0.68
	20	16.90	8.28	2.04	13.79	9.48	1.45	10.45	10.21	1.02	6.77	10.91	0.62	6.40	9.50	0.67	6.40	9.50	0.67
	25	16.84	9.20	1.83	13.78	10.50	1.31	10.42	11.32	0.92	6.83	12.02	0.57	6.55	11.10	0.59	6.55	11.10	0.59
30	/	/	/	/	/	/	/	/	/	/	/	/	/	/	/	/	/	/	/
35	/	/	/	/	/	/	/	/	/	/	/	/	/	/	/	/	/	/	/
30	-25	9.17	1.98	4.63	9.17	1.98	4.63	8.98	2.01	4.47	5.90	2.26	2.61	2.85	2.52	1.13	2.85	2.52	1.13
	-20	10.68	2.17	4.92	10.68	2.17	4.92	8.90	2.45	3.63	5.96	2.65	2.25	3.54	2.93	1.21	3.54	2.93	1.21
	-15	12.40	2.52	4.92	11.93	2.57	4.64	8.93	2.86	3.13	5.94	3.10	1.92	4.28	3.45	1.24	4.28	3.45	1.24
	-10	13.84	2.83	4.89	12.03	2.88	4.18	8.91	3.12	2.86	5.84	3.47	1.68	4.99	3.57	1.40	4.99	3.57	1.40
	-7	14.83	2.92	5.08	12.02	3.10	3.88	8.88	3.45	2.57	5.89	3.98	1.48	5.50	4.15	1.33	5.50	4.15	1.33
	-5	15.26	3.22	4.74	11.91	3.36	3.54	8.82	3.55	2.48	5.87	4.28	1.37	5.87	4.28	1.37	5.87	4.28	1.37
	-2	15.94	3.49	4.57	11.51	3.62	3.18	8.52	4.05	2.10	5.66	4.65	1.22	5.20	4.92	1.06	5.20	4.92	1.06
	0	16.47	3.69	4.46	11.24	3.80	2.96	8.33	4.35	1.91	5.54	5.25	1.05	5.54	5.25	1.06	5.54	5.25	1.06
	2	16.92	3.89	4.35	11.06	4.10	2.70	8.24	4.59	1.79	5.87	5.43	1.08	5.87	5.43	1.08	5.87	5.43	1.08
	5	17.42	4.25	4.10	12.83	4.80	2.67	9.48	5.60	1.69	6.24	6.23	1.00	5.15	6.50	0.79	5.15	6.50	0.79
	7	17.94	4.55	3.94	14.05	5.30	2.65	10.49	5.92	1.77	6.82	6.72	1.01	5.20	6.80	0.76	5.20	6.80	0.76
	10	18.34	5.35	3.43	14.12	6.50	2.17	10.42	7.10	1.47	6.95	7.76	0.90	5.50	7.30	0.75	5.50	7.30	0.75
	12	18.64	5.96	3.13	13.87	7.20	1.93	10.39	7.80	1.33	7.00	8.30	0.84	5.80	8.00	0.73	5.80	8.00	0.73
	15	17.57	6.45	2.72	13.97	7.35	1.90	10.51	8.04	1.31	6.93	8.87	0.78	6.40	8.30	0.77	6.40	8.30	0.77
	20	16.63	6.80	2.45	13.80	8.00	1.73	10.43	8.89	1.17	6.77	9.56	0.71	6.50	8.60	0.76	6.50	8.60	0.76
	25	16.58	7.90	2.10	13.79	8.58	1.61	10.54	9.55	1.10	6.98	10.25	0.68	6.80	9.00	0.76	6.80	9.00	0.76
30	16.14	9.30	1.74	14.01	10.20	1.37	10.52	11.01	0.96	7.33	11.60	0.63	7.40	9.50	0.78	7.40	9.50	0.78	
35	/	/	/	/	/	/	/	/	/	/	/	/	/	/	/	/	/	/	/
35	-25	8.99	1.88	4.78	8.99	1.88	4.78	8.90	1.89	4.71	5.96	2.09	2.85	2.71	2.40	1.13	2.71	2.40	1.13
	-20	10.51	2.15	4.89	10.51	2.15	4.87	8.93	2.35	3.80	5.93	2.54	2.33	3.43	2.79	1.23	3.43	2.79	1.23
	-15	12.22	2.27	5.38	11.99	2.29	5.23	8.93	2.67	3.34	5.84	2.85	2.05	4.18	3.12	1.34	4.18	3.12	1.34
	-10	13.00	2.52	5.16	12.03	2.56	4.70	8.97	2.84	3.16	5.87	3.38	1.74	4.85	3.48	1.39	4.85	3.48	1.39
	-7	14.60	2.71	5.39	12.00	2.80	4.29	8.84	3.26	2.71	5.91	3.60	1.64	5.36	3.69	1.45	5.36	3.69	1.45
	-5	14.97	2.88	5.20	11.88	2.94	4.04	8.79	3.31	2.65	5.86	3.70	1.58	5.71	3.72	1.53	5.71	3.72	1.53
	-2	15.24	3.13	4.87	11.49	3.20	3.59	8.38	3.68	2.28	5.70	4.12	1.38	5.06	4.38	1.16	5.06	4.38	1.16
	0	15.48	3.41	4.54	11.29	3.54	3.19	8.36	3.92	2.13	5.59	4.40	1.27	5.39	4.67	1.15	5.39	4.67	1.15
	2	15.60	3.70	4.22	11.00	3.80	2.89	8.27	4.20	1.97	5.76	4.84	1.19	5.76	4.84	1.19	5.76	4.84	1.19
	5	15.85	3.97	3.99	12.76	4.30	2.97	9.54	4.80	1.99	6.32	5.06	1.25	5.20	5.52	0.94	5.20	5.52	0.94
	7	16.31	4.25	3.84	14.00	4.70	2.98	10.54	5.06	2.08	6.89	5.50	1.25	5.30	5.70	0.93	5.30	5.70	0.93
	10	18.03	4.64	3.89	14.06	5.36	2.62	10.47	5.82	1.80	6.82	6.27	1.09	5.50	6.20	0.89	5.50	6.20	0.89
	12	18.35	5.05	3.63	13.99	5.70	2.45	10.41	6.05	1.72	6.12	6.60	0.93	5.65	6.90	0.82	5.65	6.90	0.82
	15	17.31	5.21	3.32	13.94	6.20	2.25	10.37	6.80	1.53	6.94	7.28	0.95	5.85	7.40	0.79	5.85	7.40	0.79
	20	16.37	6.07	2.70	13.79	7.00	1.97	10.35	7.65	1.35	6.88	8.30	0.83	6.19	8.00	0.77	6.19	8.00	0.77
	25	16.29	6.94	2.35	13.80	7.36	1.88	10.26	8.46	1.21	6.90	8.61	0.80	6.70	8.60	0.78	6.70	8.60	0.78
30	15.85	8.00	1.98	14.02	8.30	1.69	10.53	9.15	1.15	7.54	9.42	0.80	6.85	9.00	0.76	6.85	9.00	0.76	
35	15.01	10.15	1.48	13.99	10.25	1.36	10.35	10.62	0.97	8.23	10.86	0.76	7.20	9.30	0.77	7.20	9.30	0.77	
40	-25	8.80	1.75	5.03	8.80	1.75	5.03	8.80	1.75	5.03	5.92	2.00	2.96	2.81	2.31	1.22	2.81	2.31	1.22
	-20	10.32	2.00	5.16	10.32	2.00	5.16	8.88	2.08	4.27	5.96	2.46	2.42	3.56	2.70	1.32	3.56	2.70	1.32
	-15	12.03	2.17	5.54	11.92	2.20	5.42	8.94	2.50	3.58	5.86	2.66	2.20	4.33	2.80	1.55	4.33	2.80	1.55
	-10	13.23	2.44	5.42	12.06	2.45	4.92	8.90	2.76	3.23	5.88	3.08	1.91	5.01	3.18	1.58	5.01	3.18	1.58
	-7	13.84	2.65	5.22	12.17	2.67	4.56	8.89	2.95	3.01	5.92	3.30	1.79	5.53	3.46	1.60	5.53	3.46	1.60
	-5	14.20	2.76	5.14	11.85	2.78	4.26	8.75	3.06	2.85	5.91	3.59	1.65	5.91	3.59	1.65	5.91	3.59	1.65
	-2	14.79	2.99	4.95	11.89	3.00	3.96	8.86	3.31	2.68	5.90	3.76	1.57	5.00	3.79	1.32	5.00	3.79	1.32
	0	15.23	3.15	4.83	11.71	3.18	3.68	8.52	3.50	2.44	6.28	3.98	1.58	5.30	3.98	1.33	5.30	3.98	1.33
	2	15.68	3.33	4.71	11.60	3.35	3.46	8.78	3.74	2.35	6.65	4.12	1.61	5.65	4.11	1.38	5.65	4.11	1.38
	5	16.30	3.60	4.53	13.13	3.97	3.31	9.75	4.34	2.25	7.22	4.58	1.58	4.29	4.71	0.91	4.29	4.71	0.91
	7	17.10	3.90	4.38	14.04	4.30	3.27	10.44	4.65	2.25	7.58	4.95	1.53	4.48	4.68	0.96	4.48	4.68	0.96
	10	17.73	4.23	4.19	14.13	4.76	2.97	10.55	5.20	2.03	7.94	5.46	1.45	4.77	5.03	0.95	4.77	5.03	0.95
	12	18.02	4.55	3.96	13.94	5.18	2.69	10.41	5.62	1.85	8.41	5.80	1.45	4.96	5.38	0.92	4.96	5.38	0.92
	15	17.01	4.75	3.58	14.10	5.45	2.59	10.43	6.10	1.71	8.21	6.56	1.25	5.25	5.76	0.91	5.25	5.76	0.91
	20	16.08	5.00	3.22	13.91	5.85	2.38	10.45	6.43	1.62	7.09	6.90	1.03	5.73	6.18	0.93	5.73	6.18	0.9

Table 2-6.4: 14kW heating capacity (continued)

LWT	DB	Maximum			100% (Normal)			75%			50%			25%			Minimum		
		HC	COP	PI	HC	COP	PI	HC	COP	PI	HC	COP	PI	HC	COP	PI	HC	COP	PI
45	-25	8.62	1.67	5.16	8.62	1.67	5.16	8.62	1.67	5.16	5.97	1.81	3.30	3.26	2.00	1.63	3.26	2.00	1.63
	-20	10.14	1.90	5.34	10.14	1.90	5.34	8.90	2.00	4.45	5.91	2.38	2.48	4.05	2.50	1.62	4.05	2.50	1.62
	-15	11.84	2.16	5.48	11.84	2.16	5.48	8.93	2.43	3.67	5.86	2.65	2.21	4.90	2.75	1.78	4.90	2.75	1.78
	-10	12.26	2.27	5.40	12.05	2.32	5.19	8.93	2.55	3.50	5.88	2.73	2.15	5.61	2.80	2.00	5.61	2.80	2.00
	-7	12.91	2.43	5.31	12.00	2.40	5.00	8.92	2.67	3.34	6.28	2.92	2.15	6.28	2.92	2.15	6.28	2.92	2.15
	-5	13.16	2.65	4.97	12.07	2.61	4.62	8.99	2.77	3.24	6.59	3.10	2.13	6.59	3.10	2.13	6.59	3.10	2.13
	-2	13.53	2.76	4.90	12.36	2.73	4.53	9.17	2.98	3.08	6.90	3.21	2.15	4.78	3.20	1.49	4.78	3.20	1.49
	0	13.80	2.94	4.69	12.24	2.90	4.22	9.15	3.17	2.89	6.81	3.41	2.00	4.90	3.25	1.51	4.90	3.25	1.51
	2	14.89	3.18	4.68	12.50	3.05	4.10	9.43	3.29	2.87	7.17	3.55	2.02	5.10	3.37	1.51	5.10	3.37	1.51
	5	14.93	3.32	4.50	13.45	3.52	3.82	9.94	3.92	2.54	7.74	4.00	1.94	4.77	3.50	1.36	4.77	3.50	1.36
	7	16.01	3.56	4.50	14.10	3.75	3.76	10.37	4.23	2.45	8.07	4.43	1.82	4.98	3.66	1.36	4.98	3.66	1.36
	10	17.39	3.88	4.48	14.17	4.25	3.33	10.55	4.65	2.27	8.54	4.77	1.79	5.29	3.87	1.37	5.29	3.87	1.37
	12	17.66	4.13	4.28	14.11	4.54	3.11	10.39	4.85	2.14	9.05	4.95	1.83	5.49	3.96	1.39	5.49	3.96	1.39
	15	16.70	4.21	3.97	14.03	4.82	2.91	10.43	5.40	1.93	9.00	5.64	1.60	5.80	4.13	1.40	5.80	4.13	1.40
	20	15.76	4.55	3.46	13.60	5.15	2.64	10.24	5.75	1.78	8.04	5.97	1.35	6.32	4.36	1.45	6.32	4.36	1.45
	25	15.63	5.18	3.02	13.92	5.45	2.55	10.57	6.06	1.74	8.89	6.26	1.42	6.83	4.49	1.52	6.83	4.49	1.52
30	15.18	6.01	2.53	14.18	6.25	2.27	10.41	6.84	1.52	9.69	6.90	1.40	7.35	4.63	1.59	7.35	4.63	1.59	
35	14.34	7.28	1.97	14.05	7.31	1.92	10.54	7.74	1.36	10.54	7.74	1.36	7.86	5.85	1.34	7.86	5.85	1.34	
50	-25	8.43	1.63	5.17	8.43	1.63	5.17	8.43	1.63	5.17	5.92	1.78	3.33	3.47	1.90	1.83	3.47	1.90	1.83
	-20	9.94	1.84	5.40	9.94	1.84	5.40	8.90	1.96	4.54	5.92	2.25	2.63	4.34	2.40	1.81	4.34	2.40	1.81
	-15	11.62	2.06	5.64	11.62	2.06	5.64	8.91	2.30	3.88	5.97	2.60	2.30	5.25	2.67	1.97	5.25	2.67	1.97
	-10	12.83	2.10	6.11	12.03	2.14	5.62	8.88	2.40	3.70	5.98	2.70	2.21	5.98	2.70	2.21	5.98	2.70	2.21
	-7	13.78	2.39	5.77	12.11	2.36	5.11	9.26	2.53	3.66	6.59	2.75	2.40	6.59	2.75	2.40	6.59	2.75	2.40
	-5	14.01	2.49	5.63	12.04	2.44	4.93	8.90	2.64	3.37	7.03	2.78	2.53	7.03	2.60	2.70	7.03	2.60	2.70
	-2	14.88	2.57	5.79	12.38	2.48	4.99	9.18	2.70	3.40	7.19	2.83	2.54	4.72	2.75	1.72	4.72	2.75	1.72
	0	15.08	2.70	5.59	12.30	2.63	4.68	9.20	2.84	3.24	7.58	2.97	2.55	4.80	2.83	1.70	4.80	2.83	1.70
	2	15.50	2.83	5.48	12.52	2.74	4.57	9.37	2.94	3.19	7.97	3.08	2.59	4.92	2.94	1.68	4.92	2.94	1.68
	5	15.75	3.06	5.15	13.30	3.27	4.07	10.09	3.48	2.90	8.59	3.66	2.35	4.74	3.10	1.53	4.74	3.10	1.53
	7	16.06	3.25	4.94	13.77	3.55	3.88	10.27	3.76	2.73	8.91	3.99	2.23	4.96	3.24	1.53	4.96	3.24	1.53
	10	17.02	3.55	4.79	14.00	3.88	3.61	10.28	4.10	2.51	9.07	4.25	2.13	5.29	3.44	1.54	5.29	3.44	1.54
	12	17.26	3.75	4.60	13.94	4.02	3.47	10.36	4.35	2.38	9.61	4.43	2.17	5.50	3.55	1.55	5.50	3.55	1.55
	15	16.35	3.87	4.22	13.90	4.30	3.23	10.36	4.75	2.18	9.60	4.94	1.94	5.83	3.73	1.56	5.83	3.73	1.56
	20	15.40	4.09	3.77	13.89	4.50	3.09	10.21	5.10	2.00	8.33	5.28	1.58	6.37	4.01	1.59	6.37	4.01	1.59
	25	15.25	4.63	3.29	13.80	4.83	2.86	10.33	5.25	1.97	9.21	5.41	1.70	6.92	4.23	1.63	6.92	4.23	1.63
30	14.79	5.34	2.77	14.05	5.46	2.57	10.46	5.90	1.77	10.04	5.99	1.68	7.46	4.46	1.67	7.46	4.46	1.67	
35	13.95	6.36	2.19	13.95	6.36	2.19	10.92	6.65	1.64	10.92	6.65	1.64	8.00	5.23	1.53	8.00	5.23	1.53	
55	-25	8.42	1.61	5.23	8.42	1.61	5.23	8.42	1.61	5.23	5.97	1.73	3.45	3.96	1.95	2.03	3.96	1.95	2.03
	-20	9.90	1.83	5.41	9.90	1.83	5.41	8.94	1.93	4.63	5.94	2.23	2.66	4.83	2.00	2.42	4.83	2.00	2.42
	-15	11.59	2.03	5.71	11.59	2.03	5.71	8.88	2.20	4.04	5.94	2.55	2.33	5.83	2.05	2.84	5.83	2.05	2.84
	-10	11.96	2.10	5.70	11.96	2.10	5.70	8.96	2.30	3.90	6.59	2.62	2.51	6.59	2.10	3.14	6.59	2.10	3.14
	-7	12.85	2.28	5.64	12.00	2.15	5.58	9.09	2.40	3.79	7.26	2.65	2.74	7.26	2.15	3.38	7.26	2.15	3.38
	-5	12.89	2.37	5.44	12.17	2.28	5.34	8.93	2.48	3.60	7.73	2.77	2.79	7.73	2.20	3.51	7.73	2.20	3.51
	-2	13.27	2.43	5.46	12.44	2.40	5.18	9.32	2.53	3.68	7.82	2.80	2.79	4.66	2.30	2.03	4.66	2.30	2.03
	0	13.54	2.59	5.23	12.39	2.45	5.06	9.36	2.68	3.49	7.70	2.93	2.63	4.75	2.38	2.00	4.75	2.38	2.00
	2	14.20	2.74	5.18	12.50	2.60	4.81	9.45	2.84	3.33	8.09	2.99	2.70	4.89	2.50	1.96	4.89	2.50	1.96
	5	15.02	2.86	5.25	13.21	2.99	4.42	10.00	3.23	3.10	9.50	3.24	2.93	4.71	2.70	1.75	4.71	2.70	1.75
	7	15.54	3.07	5.06	13.80	3.15	4.38	10.19	3.47	2.94	9.90	3.51	2.82	4.94	2.83	1.75	4.94	2.83	1.75
	10	16.90	3.29	5.14	13.71	3.64	3.77	10.18	3.90	2.61	9.19	4.00	2.30	5.29	3.02	1.75	5.29	3.02	1.75
	12	17.13	3.48	4.92	13.81	3.85	3.59	10.26	4.10	2.50	9.73	4.15	2.34	5.51	3.14	1.75	5.51	3.14	1.75
	15	16.21	3.59	4.52	13.78	3.99	3.45	10.27	4.36	2.36	9.74	4.48	2.17	5.86	3.33	1.76	5.86	3.33	1.76
	20	15.27	3.77	4.05	13.77	4.18	3.29	10.32	4.62	2.23	8.53	4.70	1.81	6.43	3.65	1.76	6.43	3.65	1.76
	25	15.11	4.25	3.56	13.67	4.50	3.04	10.22	4.70	2.18	9.43	4.86	1.94	7.00	3.97	1.76	7.00	3.97	1.76
30	14.65	4.80	3.05	13.67	4.98	2.75	10.28	5.27	1.95	10.28	5.27	1.95	7.57	4.28	1.77	7.57	4.28	1.77	
35	13.79	5.68	2.43	13.79	5.68	2.43	11.18	5.82	1.92	11.18	5.82	1.92	8.14	4.60	1.77	8.14	4.60	1.77	
60	-25	8.20	1.47	5.58	8.20	1.47	5.58	8.20	1.47	5.58	5.97	1.65	3.62	4.07	1.83	2.22	4.07	1.83	2.22
	-20	9.68	1.70	5.70	9.68	1.70	5.70	8.97	1.78	5.04	5.98	1.98	3.02	5.14	1.90	2.71	5.14	1.90	2.71
	-15	11.38	1.87	6.08	11.38	1.87	6.08	8.94	2.10	4.26	6.06	2.37	2.56	6.06	1.93	3.14	6.06	1.93	3.14
	-10	12.29	2.08	5.91	12.29	2.08	5.91	8.71	2.20	3.96	6.81	2.49	2.73	6.81	2.00	3.41	6.81	2.00	3.41
	-7	12.77	2.10	6.08	12.77	2.10	6.08	9.03	2.30	3.93	7.52	2.53	2.97	7.52	2.05	3.67	7.52	2.05	3.67
	-5	12.71	2.18	5.82	12.71	2.18	5.82	8.98	2.43	3.70	7.99	2.55	3.13	7.99	2.10	3.80	7.99	2.10	3.80
	-2	13.28	2.28	5.83	12.98	2.31	5.62	9.28	2.62	3.54	8.19	2.66	3.08	4.75	2.20	2.16	4.75	2.20	2.16
	0	13.92	2.34	5.95	13.01	2.40	5.42	9.30	2.68	3.47	8.04	2.75	2.92	4.85	2.27	2.14	4.85	2.27	2.14
	2	14.16	2.35	6.02	13.10	2.46	5.33	9.29	2.70	3.44	8.44	2.78	3.04	4.95	2.37	2.09	4.95	2.37	2.09
	5	15.00	2.54	5.90	13.86	2.70	5.13	9.88	2.88	3.43	9.18	2.93	3.13	4.70	2.50	1.88	4.70	2.50	1.88
	7	15.54	2.85	5.46	13.75	3.07	4.48	10.15	3.18	3.19	9.46	3.23	2.93	5.20	2.61	1.99	5.20	2.61	1.99
	10	16.45	2.95	5.58	13.78	3.10	4.45	10.29	3.28	3.14	9.30	3.39	2.74	5.50	2.77	1.99	5.50	2.77	1.99
	12	16.66	3.11	5.36	13.90	3.32	4.19	10.19	3.65	2.79	9.84	3.68	2.67	5.70	2.87	1.98	5.70	2.87	1.98
	15	15.78	3.30	4.78	13.80	3.50	3.94	10.14	3.90	2.60	9.81	4.00	2.45	6.10	3.03	2.01			

R290 M thermal Nature Plus Series



Table 2-6.4: 14kW heating capacity (continued)

LWT	DB	Maximum			100% (Normal)			75%			50%			25%			Minimum		
		HC	COP	PI	HC	COP	PI	HC	COP	PI	HC	COP	PI	HC	COP	PI	HC	COP	PI
65	-25	/	/	/	/	/	/	/	/	/	/	/	/	/	/	/	/	/	/
	-20	9.46	1.66	5.70	9.46	1.66	5.70	8.88	1.72	5.16	5.91	1.95	3.03	4.87	1.70	2.86	4.87	1.70	2.86
	-15	10.97	1.74	6.30	10.97	1.74	6.30	8.94	1.92	4.66	5.97	2.06	2.90	5.97	1.75	3.41	5.97	1.75	3.41
	-10	12.12	1.98	6.12	11.17	2.01	5.56	8.82	2.12	4.16	6.75	2.24	3.01	6.75	1.80	3.75	6.75	1.80	3.75
	-7	12.07	2.08	5.80	12.07	2.08	5.80	8.94	2.20	4.06	7.21	2.33	3.09	7.21	1.85	3.90	7.21	1.85	3.90
	-5	12.05	2.12	5.68	12.05	2.12	5.68	9.29	2.22	4.18	7.67	2.43	3.16	7.67	1.95	3.93	7.67	1.95	3.93
	-2	12.52	2.21	5.67	12.52	2.21	5.67	9.18	2.34	3.92	7.87	2.49	3.16	4.59	2.03	2.27	4.59	2.03	2.27
	0	12.86	2.26	5.69	12.86	2.26	5.69	9.22	2.39	3.86	8.36	2.55	3.28	4.69	2.09	2.24	4.69	2.09	2.24
	2	13.08	2.34	5.59	13.08	2.34	5.59	9.32	2.50	3.73	8.85	2.62	3.38	4.79	2.18	2.20	4.79	2.18	2.20
	5	13.85	2.50	5.54	13.85	2.50	5.54	9.94	2.76	3.60	8.83	2.91	3.03	4.50	2.31	1.95	4.50	2.31	1.95
	7	15.04	2.76	5.45	14.52	2.80	5.19	10.36	2.90	3.57	9.04	2.93	3.09	4.65	2.41	1.93	4.65	2.41	1.93
	10	15.51	2.82	5.50	13.64	2.90	4.70	10.38	3.06	3.39	8.93	3.24	2.76	4.90	2.56	1.91	4.90	2.56	1.91
	12	16.14	2.85	5.66	13.74	3.03	4.53	10.25	3.20	3.20	9.45	3.30	2.86	5.10	2.68	1.90	5.10	2.68	1.90
	15	15.29	2.98	5.13	13.72	3.17	4.33	10.16	3.40	2.99	9.42	3.59	2.62	5.45	2.86	1.90	5.45	2.86	1.90
	20	14.21	3.24	4.39	13.71	3.36	4.08	10.23	3.56	2.87	8.27	3.87	2.14	5.95	3.00	1.98	5.95	3.00	1.98
	25	14.12	3.45	4.09	13.71	3.48	3.94	10.17	3.81	2.67	9.14	3.98	2.30	6.50	3.30	1.97	6.50	3.30	1.97
30	13.67	3.83	3.57	13.67	3.83	3.57	10.34	4.03	2.57	9.96	4.26	2.34	7.20	3.50	2.06	7.20	3.50	2.06	
35	/	/	/	/	/	/	/	/	/	/	/	/	/	/	/	/	/	/	
70	-25	/	/	/	/	/	/	/	/	/	/	/	/	/	/	/	/	/	/
	-20	9.33	1.52	6.14	9.33	1.52	6.14	8.94	1.57	5.70	5.96	1.85	3.22	4.66	1.55	3.01	4.66	1.55	3.01
	-15	10.30	1.64	6.28	10.30	1.64	6.28	8.90	1.90	4.68	5.94	1.98	3.00	5.61	1.60	3.51	5.61	1.60	3.51
	-10	10.77	1.76	6.12	10.77	1.76	6.12	8.86	1.96	4.52	6.31	2.07	3.05	6.31	1.65	3.82	6.31	1.65	3.82
	-7	10.80	1.82	5.93	10.80	1.82	5.93	8.84	2.00	4.42	6.96	2.12	3.28	6.96	1.70	4.09	6.96	1.70	4.09
	-5	10.70	1.90	5.63	10.70	1.90	5.63	9.04	2.05	4.41	7.42	2.20	3.37	7.42	1.75	4.24	7.42	1.75	4.24
	-2	11.06	1.97	5.61	11.06	1.97	5.61	9.16	2.10	4.36	7.61	2.28	3.34	4.43	1.85	2.39	4.43	1.85	2.39
	0	11.17	2.00	5.59	11.17	2.00	5.58	9.20	2.17	4.24	8.08	2.33	3.47	4.53	1.91	2.37	4.53	1.91	2.37
	2	11.63	2.04	5.70	11.63	2.04	5.70	9.40	2.24	4.20	8.80	2.38	3.70	4.63	1.99	2.33	4.63	1.99	2.33
	5	13.62	2.20	6.19	13.14	2.28	5.76	9.81	2.58	3.80	8.81	2.75	3.20	4.81	2.11	2.28	4.81	2.11	2.28
	7	13.85	2.43	5.70	13.85	2.43	5.70	10.37	2.70	3.84	8.62	2.87	3.00	4.99	2.20	2.27	4.99	2.20	2.27
	10	14.23	2.55	5.58	13.75	2.63	5.23	10.22	2.86	3.57	8.94	3.00	2.98	5.25	2.36	2.23	5.25	2.36	2.23
	12	15.25	2.62	5.82	13.70	2.75	4.98	10.17	3.00	3.39	9.45	3.08	3.07	5.45	2.49	2.19	5.45	2.49	2.19
	15	14.90	2.79	5.34	13.62	2.93	4.65	10.23	3.20	3.20	9.40	3.33	2.82	5.76	2.69	2.14	5.76	2.69	2.14
	20	13.70	3.11	4.41	13.70	3.11	4.41	10.13	3.35	3.02	8.24	3.58	2.30	6.00	2.92	2.05	6.00	2.92	2.05
	25	13.83	3.26	4.24	13.63	3.26	4.18	10.17	3.63	2.80	9.11	3.73	2.44	6.20	3.10	2.00	6.20	3.10	2.00
30	/	/	/	/	/	/	/	/	/	/	/	/	/	/	/	/	/	/	
35	/	/	/	/	/	/	/	/	/	/	/	/	/	/	/	/	/	/	
75	-25	/	/	/	/	/	/	/	/	/	/	/	/	/	/	/	/	/	/
	-20	/	/	/	/	/	/	/	/	/	/	/	/	/	/	/	/	/	/
	-15	9.75	1.55	6.29	9.75	1.55	6.29	8.96	1.71	5.24	5.90	1.90	3.11	5.29	1.35	3.92	5.29	1.35	3.92
	-10	9.90	1.65	6.00	9.90	1.65	6.00	8.85	1.77	5.00	5.93	2.03	2.92	5.93	1.45	4.09	5.93	1.45	4.09
	-7	10.11	1.75	5.78	10.11	1.75	5.78	8.84	1.90	4.65	6.60	2.07	3.19	6.60	1.50	4.40	6.60	1.50	4.40
	-5	10.21	1.83	5.58	10.21	1.83	5.58	9.04	1.95	4.63	7.05	2.12	3.33	7.05	1.55	4.55	7.05	1.55	4.55
	-2	9.97	1.92	5.19	9.97	1.92	5.19	9.16	1.98	4.63	7.23	2.20	3.29	4.26	1.68	2.54	4.26	1.68	2.54
	0	10.32	1.95	5.29	10.32	1.95	5.29	9.20	2.05	4.49	7.69	2.28	3.37	4.36	1.73	2.52	4.36	1.73	2.52
	2	10.62	2.00	5.31	10.62	2.00	5.31	9.40	2.19	4.29	8.48	2.33	3.64	4.46	1.79	2.49	4.46	1.79	2.49
	5	12.49	2.16	5.78	12.49	2.16	5.78	9.81	2.28	4.30	8.50	2.48	3.43	4.63	1.92	2.42	4.63	1.92	2.42
	7	12.65	2.18	5.80	12.65	2.18	5.80	10.37	2.30	4.51	8.13	2.56	3.18	4.80	2.00	2.40	4.80	2.00	2.40
	10	12.96	2.32	5.59	12.96	2.32	5.59	10.22	2.55	4.01	8.63	2.69	3.21	5.03	2.15	2.34	5.03	2.15	2.34
	12	13.51	2.39	5.65	13.51	2.39	5.65	10.17	2.65	3.84	9.14	2.72	3.36	5.23	2.29	2.28	5.23	2.29	2.28
	15	13.33	2.43	5.49	13.33	2.43	5.48	10.23	2.75	3.72	9.12	2.83	3.22	5.53	2.52	2.19	5.53	2.52	2.19
	20	11.98	2.52	4.75	11.98	2.52	4.75	10.13	2.85	3.55	7.99	3.00	2.66	5.80	2.70	2.15	5.80	2.70	2.15
	25	/	/	/	/	/	/	/	/	/	/	/	/	/	/	/	/	/	/
30	/	/	/	/	/	/	/	/	/	/	/	/	/	/	/	/	/	/	
35	/	/	/	/	/	/	/	/	/	/	/	/	/	/	/	/	/	/	
80	-25	/	/	/	/	/	/	/	/	/	/	/	/	/	/	/	/	/	/
	-20	/	/	/	/	/	/	/	/	/	/	/	/	/	/	/	/	/	/
	-15	/	/	/	/	/	/	/	/	/	/	/	/	/	/	/	/	/	/
	-10	8.00	1.27	6.30	8.00	1.27	6.30	8.00	1.27	6.30	5.97	1.40	4.27	5.77	1.30	4.44	5.77	1.30	4.44
	-7	9.12	1.45	6.29	9.12	1.45	6.29	8.84	1.45	6.10	6.14	1.72	3.57	6.14	1.50	4.09	6.14	1.50	4.09
	-5	9.25	1.70	5.44	9.25	1.70	5.44	8.95	1.74	5.15	6.59	1.95	3.38	6.59	1.40	4.71	6.59	1.40	4.71
	-2	9.80	1.73	5.66	9.80	1.73	5.67	9.16	1.81	5.06	6.75	1.98	3.41	4.10	1.50	2.73	4.10	1.50	2.73
	0	9.90	1.85	5.35	9.90	1.85	5.35	9.27	1.92	4.83	7.20	2.05	3.51	4.20	1.55	2.71	4.20	1.55	2.71
	2	10.30	1.88	5.48	10.30	1.88	5.48	9.29	1.98	4.69	8.02	2.08	3.85	4.30	1.60	2.69	4.30	1.60	2.69
	5	11.16	1.98	5.64	11.16	1.98	5.64	9.81	2.03	4.83	8.16	2.12	3.85	4.45	1.72	2.59	4.45	1.72	2.59
	7	11.22	2.04	5.50	11.22	2.04	5.50	10.30	2.14	4.81	8.26	2.26	3.65	4.60	1.80	2.56	4.60	1.80	2.56
	10	11.72	2.08	5.63	11.72	2.08	5.64	10.16	2.20	4.62	8.14	2.33	3.49	4.81	1.95	2.47	4.81	1.95	2.47
	12	12.05	2.17	5.55	12.05	2.17	5.56	10.12	2.32	4.36	8.62	2.44	3.53	5.00	2.10	2.38	5.00	2.10	2.38
	15	12.80	2.24	5.71	12.80	2.24	5.71	10.30	2.48	4.15	8.62	2.53	3.41	5.30	2.35	2.26	5.30	2.35	2.26
	20	/	/	/	/	/	/	/	/	/	/	/	/	/	/	/	/	/	/
	25	/	/	/	/	/	/	/	/	/	/	/	/	/	/	/	/	/	/
30	/	/	/	/	/	/	/	/	/	/	/	/	/	/	/	/	/	/	
35	/	/	/	/	/	/	/	/	/	/	/	/	/	/	/	/	/	/	

Abbreviations:

LWT: Leaving water temperature (°C)

DB: Dry-bulb temperature for outdoor air temperature (°C)

HC: Total heating capacity (kW)

PI: Power input (kW)

Table 2-6.5: 16kW heating capacity

LWT	DB	Maximum			100% (Normal)			75%			50%			25%			Minimum		
		HC	COP	PI	HC	COP	PI	HC	COP	PI	HC	COP	PI	HC	COP	PI	HC	COP	PI
25	-25	10.15	1.93	5.26	10.15	1.93	5.26	9.85	1.96	5.03	6.59	2.40	2.75	2.91	2.88	1.01	2.91	2.88	1.01
	-20	11.68	2.44	4.79	11.68	2.44	4.79	9.86	2.64	3.73	6.55	2.87	2.28	3.61	3.40	1.06	3.61	3.40	1.06
	-15	13.38	2.66	5.03	13.15	2.68	4.91	9.83	3.11	3.16	6.60	3.35	1.97	4.36	3.96	1.10	4.36	3.96	1.10
	-10	15.18	2.88	5.27	13.09	2.91	4.50	9.86	3.30	2.99	6.59	3.79	1.74	5.08	4.10	1.24	5.08	4.10	1.24
	-7	16.17	3.07	5.27	13.14	3.12	4.21	9.80	3.74	2.62	6.62	4.16	1.59	5.60	4.51	1.24	5.60	4.51	1.24
	-5	16.54	3.32	4.98	13.03	3.38	3.86	9.79	3.85	2.54	6.61	4.50	1.47	5.97	4.59	1.30	5.97	4.59	1.30
	-2	17.22	3.52	4.89	13.01	3.75	3.47	9.78	4.34	2.25	6.49	5.11	1.27	5.29	5.53	0.96	5.29	5.53	0.96
	0	17.71	3.78	4.69	13.04	4.02	3.24	9.77	4.67	2.09	6.55	5.49	1.19	5.63	5.91	0.95	5.63	5.91	0.95
	2	18.24	3.96	4.61	13.00	4.35	2.99	9.72	5.04	1.93	6.61	5.99	1.10	5.97	6.16	0.97	5.97	6.16	0.97
	5	18.97	4.84	3.92	15.00	4.92	3.05	11.09	5.97	1.86	7.36	6.60	1.12	5.50	6.80	0.81	5.50	6.80	0.81
	7	19.51	5.05	3.86	15.63	5.71	2.74	11.53	6.58	1.75	7.81	7.12	1.10	5.60	7.30	0.77	5.60	7.30	0.77
	10	20.15	6.15	3.28	15.64	6.89	2.27	11.62	7.57	1.53	7.62	7.97	0.96	5.90	8.25	0.72	5.90	8.25	0.72
	12	20.35	6.80	2.99	15.45	7.74	2.00	11.40	8.42	1.35	7.75	8.78	0.88	6.00	8.80	0.68	6.00	8.80	0.68
	15	18.99	7.06	2.69	15.48	8.23	1.88	11.17	9.36	1.19	7.81	9.70	0.81	6.20	9.10	0.68	6.20	9.10	0.68
	20	17.79	7.70	2.31	15.52	8.84	1.76	11.78	9.98	1.18	7.82	10.75	0.73	6.40	9.50	0.67	6.40	9.50	0.67
	25	18.08	8.44	2.14	15.47	9.68	1.60	11.57	11.01	1.05	7.56	11.73	0.64	6.55	11.10	0.59	6.55	11.10	0.59
	30	/	/	/	/	/	/	/	/	/	/	/	/	/	/	/	/	/	/
35	/	/	/	/	/	/	/	/	/	/	/	/	/	/	/	/	/	/	/
30	-25	9.92	1.80	5.51	9.92	1.80	5.52	9.82	1.81	5.44	6.57	2.21	2.97	2.85	2.52	1.13	2.85	2.52	1.13
	-20	11.51	2.10	5.48	11.51	2.10	5.48	9.87	2.25	4.39	6.52	2.61	2.50	3.54	2.93	1.21	3.54	2.93	1.21
	-15	13.34	2.49	5.36	13.12	2.50	5.24	9.80	2.77	3.53	6.58	3.05	2.16	4.28	3.45	1.24	4.28	3.45	1.24
	-10	14.86	2.62	5.67	13.04	2.70	4.84	9.84	3.00	3.28	6.54	3.42	1.91	4.99	3.57	1.40	4.99	3.57	1.40
	-7	15.95	2.72	5.86	13.17	2.83	4.65	9.85	3.27	3.01	6.58	3.80	1.73	5.50	4.15	1.33	5.50	4.15	1.33
	-5	16.30	3.00	5.43	13.06	3.09	4.23	9.86	3.51	2.81	6.55	4.00	1.64	5.87	4.28	1.37	5.87	4.28	1.37
	-2	16.98	3.30	5.15	13.08	3.35	3.91	9.75	3.91	2.49	6.57	4.51	1.46	5.20	4.92	1.06	5.20	4.92	1.06
	0	17.46	3.38	5.17	13.02	3.58	3.64	9.79	4.22	2.32	6.52	4.79	1.36	5.54	5.25	1.06	5.54	5.25	1.06
	2	17.98	3.51	5.12	12.99	3.82	3.40	9.77	4.47	2.19	6.55	5.06	1.29	5.87	5.43	1.08	5.87	5.43	1.08
	5	18.70	4.22	4.43	14.99	4.38	3.42	10.93	5.24	2.08	7.24	5.85	1.24	5.15	6.50	0.79	5.15	6.50	0.79
	7	19.22	4.48	4.29	15.62	4.98	3.14	11.57	5.63	2.06	7.68	6.45	1.19	5.20	6.80	0.76	5.20	6.80	0.76
	10	19.86	5.28	3.76	15.57	6.08	2.56	11.44	6.80	1.68	7.71	7.60	1.01	5.50	7.30	0.75	5.50	7.30	0.75
	12	20.26	5.80	3.49	15.57	6.75	2.31	11.61	7.40	1.57	7.71	8.23	0.94	5.80	8.00	0.73	5.80	8.00	0.73
	15	18.72	5.97	3.14	15.48	6.95	2.23	11.49	7.90	1.45	7.77	8.76	0.89	6.40	8.30	0.77	6.40	8.30	0.77
	20	17.53	6.40	2.74	15.52	7.39	2.10	11.59	8.55	1.36	7.96	9.23	0.86	6.50	8.60	0.76	6.50	8.60	0.76
	25	17.80	7.35	2.42	15.48	8.03	1.93	11.54	9.17	1.26	7.72	9.79	0.79	6.80	9.00	0.76	6.80	9.00	0.76
	30	16.90	9.09	1.86	15.61	9.61	1.62	11.52	10.50	1.10	7.83	11.51	0.68	7.40	9.50	0.78	7.40	9.50	0.78
35	/	/	/	/	/	/	/	/	/	/	/	/	/	/	/	/	/	/	/
35	-25	9.73	1.71	5.69	9.73	1.71	5.70	9.73	1.71	5.70	6.62	2.04	3.25	2.71	2.40	1.13	2.71	2.40	1.13
	-20	11.31	2.06	5.49	11.31	2.06	5.49	9.80	2.18	4.50	6.56	2.41	2.72	3.43	2.79	1.23	3.43	2.79	1.23
	-15	13.15	2.18	6.03	13.04	2.19	5.95	9.80	2.58	3.79	6.59	2.82	2.34	4.18	3.12	1.34	4.18	3.12	1.34
	-10	13.42	2.43	5.52	13.04	2.50	5.22	9.82	2.77	3.55	6.55	3.13	2.09	4.85	3.48	1.39	4.85	3.48	1.39
	-7	15.72	2.62	6.00	13.10	2.70	4.85	9.78	3.16	3.09	6.46	3.51	1.84	5.36	3.69	1.45	5.36	3.69	1.45
	-5	15.85	2.85	5.66	13.08	2.89	4.53	9.90	3.25	3.05	6.57	3.62	1.81	5.71	3.72	1.53	5.71	3.72	1.53
	-2	15.96	3.10	5.15	13.03	3.16	4.12	9.72	3.55	2.73	6.59	4.01	1.64	5.06	4.38	1.16	5.06	4.38	1.16
	0	16.34	3.34	4.89	13.11	3.34	3.93	9.76	3.81	2.56	6.54	4.40	1.49	5.39	4.67	1.15	5.39	4.67	1.15
	2	16.61	3.47	4.79	13.00	3.50	3.71	9.79	3.97	2.47	6.63	4.62	1.43	5.76	4.84	1.19	5.76	4.84	1.19
	5	17.25	3.85	4.48	14.76	3.92	3.77	10.75	4.61	2.33	7.29	4.98	1.46	5.20	5.52	0.94	5.20	5.52	0.94
	7	17.68	4.07	4.34	15.50	4.50	3.44	11.60	4.98	2.32	7.74	5.30	1.46	5.30	5.70	0.93	5.30	5.70	0.93
	10	19.53	4.53	4.31	15.64	5.05	3.10	11.48	5.67	2.03	7.80	6.07	1.29	5.50	6.20	0.89	5.50	6.20	0.89
	12	19.93	4.93	4.04	15.49	5.52	2.81	11.66	5.92	1.97	7.79	6.42	1.21	5.65	6.90	0.82	5.65	6.90	0.82
	15	18.44	5.10	3.62	15.50	5.90	2.63	11.51	6.69	1.72	7.75	7.18	1.08	5.85	7.40	0.79	5.85	7.40	0.79
	20	17.24	5.58	3.09	15.50	6.21	2.50	11.61	7.35	1.58	7.72	7.91	0.98	6.19	8.00	0.77	6.19	8.00	0.77
	25	17.49	6.52	2.68	15.50	7.00	2.21	11.73	7.83	1.50	7.65	8.57	0.89	6.70	8.60	0.78	6.70	8.60	0.78
	30	16.61	7.92	2.10	15.50	8.15	1.90	11.52	9.01	1.28	7.54	9.42	0.80	6.85	9.00	0.76	6.85	9.00	0.76
35	15.50	10.10	1.53	15.50	10.10	1.53	11.47	10.52	1.09	8.23	10.86	0.76	7.20	9.30	0.77	7.20	9.30	0.77	
40	-25	9.54	1.64	5.82	9.54	1.64	5.83	9.54	1.64	5.83	6.58	1.90	3.46	2.81	2.31	1.22	2.81	2.31	1.22
	-20	11.12	1.90	5.85	11.12	1.90	5.85	9.83	2.05	4.79	6.59	2.34	2.82	3.56	2.70	1.32	3.56	2.70	1.32
	-15	12.94	2.08	6.22	12.94	2.08	6.22	9.80	2.41	4.06	6.48	2.63	2.46	4.33	2.80	1.55	4.33	2.80	1.55
	-10	13.37	2.31	5.79	13.05	2.33	5.61	9.79	2.62	3.74	6.55	2.87	2.28	5.01	3.18	1.58	5.01	3.18	1.58
	-7	14.34	2.60	5.52	13.11	2.49	5.27	9.78	2.86	3.42	6.48	3.24	2.00	5.53	3.46	1.60	5.53	3.46	1.60
	-5	14.76	2.72	5.43	13.07	2.68	4.88	9.85	2.94	3.35	6.59	3.29	2.00	5.91	3.59	1.65	5.91	3.59	1.65
	-2	15.44	2.91	5.31	13.25	2.82	4.69	9.99	3.21	3.12	6.63	3.58	1.85	5.00	3.79	1.32	5.00	3.79	1.32
	0	15.96	3.10	5.15	13.21	2.99	4.41	9.93	3.42	2.91	6.69	3.64	1.84	5.30	3.98	1.33	5.30	3.98	1.33
	2	16.41	3.23	5.08	13.44	3.14	4.28	10.04	3.62	2.78	6.65	4.12	1.61	5.65	4.11	1.38	5.65	4.11	1.38
	5	16.89	3.57	4.73	14.71	3.79	3.88	10.95	4.24	2.58	7.22	4.58	1.58	4.29	4.71	0.91	4.29	4.71	0.91
	7	18.43	3.85	4.79	15.37	4.10	3.75	11.60	4.45	2.61	7.58	4.95	1.53	4.48	4.68	0.96	4.48	4.68	0.96
	10	19.22	4.12	4.67	15.52	4.55	3.41	11.71	4.93	2.38	7.94	5.46	1.45	4.77	5.03	0.95	4.77	5.03	0.95
	12	19.58	4.48	4.37	15.55	4.99	3.12	11.68	5.42	2.15	8.41	5.80	1.45	4.96	5.38	0.92	4.96	5.38	0.92
	15	18.14	4.63	3.92	15.57	5.05	3.08	11.70	5.69	2.06	8.21	6.56	1.25	5.25	5.76	0.91	5.25	5.76	0.91
	20	16.93	4.94	3.43	15.43	5.47	2.82	11.60	6.16	1.88	7.81	6.80	1.15	5.73	6.18	0.93	5.73	6.18	

R290 M thermal Nature Plus Series



Table 2-6.5: 16kW heating capacity (continued)

LWT	DB	Maximum			100% (Normal)			75%			50%			25%			Minimum		
		HC	COP	PI	HC	COP	PI	HC	COP	PI	HC	COP	PI	HC	COP	PI	HC	COP	PI
45	-25	9.32	1.57	5.94	9.32	1.57	5.92	9.32	1.57	5.92	6.54	1.79	3.65	3.26	2.00	1.63	3.26	2.00	1.63
	-20	10.91	1.82	5.99	10.91	1.82	6.00	9.76	1.94	5.03	6.61	2.24	2.95	4.05	2.50	1.62	4.05	2.50	1.62
	-15	12.70	2.07	6.14	12.70	2.07	6.12	9.80	2.25	4.35	6.56	2.60	2.52	4.90	2.75	1.78	4.90	2.75	1.78
	-10	13.35	2.15	6.21	13.01	2.17	6.00	9.77	2.49	3.93	6.54	2.68	2.44	5.61	2.80	2.00	5.61	2.80	2.00
	-7	13.98	2.40	5.83	13.00	2.30	5.65	9.74	2.59	3.76	6.57	2.88	2.28	6.28	2.92	2.15	6.28	2.92	2.15
	-5	14.70	2.51	5.86	13.16	2.42	5.43	9.82	2.69	3.65	6.59	3.10	2.13	6.59	3.10	2.13	6.59	3.10	2.13
	-2	15.30	2.70	5.67	13.44	2.61	5.15	10.01	2.92	3.43	6.90	3.21	2.15	4.78	3.20	1.49	4.78	3.20	1.49
	0	15.76	2.82	5.59	13.62	2.71	5.03	10.19	3.07	3.32	6.81	3.41	2.00	4.90	3.25	1.51	4.90	3.25	1.51
	2	16.45	3.09	5.32	13.80	2.90	4.76	10.31	3.23	3.19	7.17	3.55	2.02	5.10	3.37	1.51	5.10	3.37	1.51
	5	16.89	3.20	5.28	14.83	3.48	4.26	11.23	3.82	2.94	7.74	4.00	1.94	4.77	3.50	1.36	4.77	3.50	1.36
	7	17.26	3.47	4.97	15.50	3.65	4.25	11.71	4.01	2.92	8.07	4.43	1.82	4.98	3.66	1.36	4.98	3.66	1.36
	10	18.85	3.76	5.01	15.52	4.09	3.79	11.68	4.40	2.66	8.54	4.77	1.79	5.29	3.87	1.37	5.29	3.87	1.37
	12	19.20	4.07	4.72	15.55	4.34	3.58	11.76	4.72	2.49	9.05	4.95	1.83	5.49	3.96	1.39	5.49	3.96	1.39
	15	17.82	4.18	4.26	15.47	4.51	3.43	11.65	4.97	2.34	9.00	5.64	1.60	5.80	4.13	1.40	5.80	4.13	1.40
	20	16.61	4.45	3.73	15.54	4.69	3.31	11.57	5.45	2.12	8.04	5.97	1.35	6.32	4.36	1.45	6.32	4.36	1.45
	25	16.81	5.08	3.31	15.41	5.30	2.90	11.56	5.95	1.94	8.89	6.26	1.42	6.83	4.49	1.52	6.83	4.49	1.52
	30	15.91	5.92	2.69	15.42	5.99	2.57	11.53	6.76	1.71	9.69	6.90	1.40	7.35	4.63	1.59	7.35	4.63	1.59
	35	14.61	7.23	2.02	14.61	7.23	2.02	11.65	7.70	1.51	10.54	7.74	1.36	7.86	5.85	1.34	7.86	5.85	1.34
50	-25	9.13	1.54	5.93	9.13	1.54	5.93	9.13	1.54	5.93	6.58	1.72	3.83	3.47	1.90	1.83	3.47	1.90	1.83
	-20	10.70	1.75	6.11	10.70	1.75	6.12	9.75	1.86	5.24	6.58	2.19	3.01	4.34	2.40	1.81	4.34	2.40	1.81
	-15	12.47	1.89	6.60	12.47	1.89	6.60	9.74	2.20	4.43	6.59	2.53	2.61	5.25	2.67	1.97	5.25	2.67	1.97
	-10	13.05	2.08	6.27	12.77	2.04	6.26	9.71	2.30	4.21	6.49	2.64	2.46	5.98	2.70	2.21	5.98	2.70	2.21
	-7	14.05	2.30	6.11	13.02	2.29	5.69	9.82	2.48	3.96	6.59	2.75	2.40	6.59	2.75	2.40	6.59	2.75	2.40
	-5	14.41	2.43	5.93	13.15	2.32	5.67	9.91	2.56	3.87	7.03	2.78	2.53	7.03	2.60	2.70	7.03	2.60	2.70
	-2	15.03	2.54	5.92	13.41	2.38	5.63	10.02	2.67	3.75	7.19	2.83	2.54	4.72	2.75	1.72	4.72	2.75	1.72
	0	15.47	2.65	5.84	13.59	2.49	5.46	10.19	2.80	3.64	7.58	2.97	2.55	4.80	2.83	1.70	4.80	2.83	1.70
	2	15.92	2.77	5.75	13.71	2.61	5.25	10.22	2.86	3.57	7.97	3.08	2.59	4.92	2.94	1.68	4.92	2.94	1.68
	5	17.09	2.87	5.95	14.94	3.10	4.82	11.15	3.40	3.28	8.59	3.66	2.35	4.74	3.10	1.53	4.74	3.10	1.53
	7	17.47	3.15	5.55	15.67	3.31	4.73	11.77	3.71	3.17	8.91	3.99	2.23	4.96	3.24	1.53	4.96	3.24	1.53
	10	18.46	3.34	5.53	15.73	3.60	4.37	11.83	4.03	2.94	9.07	4.25	2.13	5.29	3.44	1.54	5.29	3.44	1.54
	12	18.77	3.54	5.30	15.68	3.82	4.10	11.60	4.19	2.77	9.61	4.43	2.17	5.50	3.55	1.55	5.50	3.55	1.55
	15	17.46	3.70	4.72	15.73	3.95	3.98	11.77	4.51	2.61	9.60	4.94	1.94	5.83	3.73	1.56	5.83	3.73	1.56
	20	16.25	4.02	4.04	15.82	4.06	3.90	11.90	4.70	2.53	8.33	5.28	1.58	6.37	4.01	1.59	6.37	4.01	1.59
	25	16.42	4.53	3.62	15.73	4.62	3.40	11.75	5.20	2.26	9.21	5.41	1.70	6.92	4.23	1.63	6.92	4.23	1.63
	30	15.53	5.23	2.97	15.53	5.23	2.97	11.78	5.85	2.02	10.04	5.99	1.68	7.46	4.46	1.67	7.46	4.46	1.67
	35	14.22	6.26	2.27	14.22	6.26	2.27	11.98	6.60	1.81	10.92	6.65	1.64	8.00	5.23	1.53	8.00	5.23	1.53
55	-25	9.01	1.53	5.89	9.01	1.53	5.89	9.01	1.53	5.89	6.54	1.67	3.91	3.96	1.95	2.03	3.96	1.95	2.03
	-20	10.63	1.72	6.18	10.63	1.72	6.19	9.81	1.84	5.33	6.56	2.17	3.02	4.83	2.00	2.42	4.83	2.00	2.42
	-15	12.06	1.80	6.70	12.06	1.80	6.70	9.81	2.13	4.61	6.54	2.43	2.69	5.83	2.05	2.84	5.83	2.05	2.84
	-10	12.71	2.05	6.20	12.49	1.95	6.41	9.80	2.20	4.45	6.59	2.62	2.51	6.59	2.10	3.14	6.59	2.10	3.14
	-7	14.10	2.18	6.47	13.00	2.10	6.19	9.77	2.29	4.27	7.26	2.65	2.74	7.26	2.15	3.38	7.26	2.15	3.38
	-5	14.01	2.27	6.17	13.19	2.18	6.05	9.86	2.38	4.14	7.73	2.77	2.79	7.73	2.20	3.51	7.73	2.20	3.51
	-2	14.62	2.41	6.07	13.44	2.26	5.96	10.06	2.51	4.01	7.82	2.80	2.79	4.66	2.30	2.03	4.66	2.30	2.03
	0	15.04	2.50	6.02	13.62	2.35	5.81	10.24	2.62	3.90	7.70	2.93	2.63	4.75	2.38	2.00	4.75	2.38	2.00
	2	15.41	2.67	5.77	13.80	2.50	5.52	10.37	2.74	3.79	8.09	2.99	2.70	4.89	2.50	1.96	4.89	2.50	1.96
	5	16.61	2.80	5.93	15.06	2.88	5.23	11.25	3.12	3.61	9.50	3.24	2.93	4.71	2.70	1.75	4.71	2.70	1.75
	7	17.00	3.02	5.63	16.00	3.05	5.25	11.99	3.24	3.70	9.90	3.51	2.82	4.94	2.83	1.75	4.94	2.83	1.75
	10	18.36	3.18	5.77	16.06	3.35	4.79	11.95	3.71	3.22	9.19	4.00	2.30	5.29	3.02	1.75	5.29	3.02	1.75
	12	18.65	3.34	5.58	15.90	3.53	4.50	11.94	3.94	3.03	9.73	4.15	2.34	5.51	3.14	1.75	5.51	3.14	1.75
	15	17.35	3.50	4.96	16.21	3.60	4.50	12.17	4.15	2.93	9.74	4.48	2.17	5.86	3.33	1.76	5.86	3.33	1.76
	20	16.12	3.71	4.35	16.12	3.71	4.34	12.00	4.33	2.77	8.53	4.70	1.81	6.43	3.65	1.76	6.43	3.65	1.76
	25	16.28	4.15	3.92	16.05	4.18	3.84	12.10	4.64	2.61	9.43	4.86	1.94	7.00	3.97	1.76	7.00	3.97	1.76
	30	15.37	4.73	3.25	15.37	4.73	3.25	12.17	5.21	2.34	10.28	5.27	1.95	7.57	4.28	1.77	7.57	4.28	1.77
	35	14.07	5.61	2.51	14.07	5.61	2.51	12.13	5.71	2.12	11.18	5.82	1.92	8.14	4.60	1.77	8.14	4.60	1.77
60	-25	8.91	1.33	6.70	8.91	1.33	6.70	8.91	1.33	6.70	6.74	1.54	4.37	4.07	1.83	2.22	4.07	1.83	2.22
	-20	10.44	1.67	6.24	10.44	1.67	6.24	9.78	1.68	5.82	6.64	1.88	3.53	5.14	1.90	2.71	5.14	1.90	2.71
	-15	11.44	1.79	6.39	11.44	1.79	6.39	9.79	1.95	5.02	6.51	2.34	2.78	6.06	1.93	3.14	6.06	1.93	3.14
	-10	12.87	1.95	6.59	12.87	1.95	6.59	9.80	2.16	4.54	6.81	2.49	2.73	6.81	2.00	3.41	6.81	2.00	3.41
	-7	13.48	2.03	6.65	13.48	2.03	6.65	9.79	2.30	4.26	7.52	2.53	2.97	7.52	2.05	3.67	7.52	2.05	3.67
	-5	13.58	2.10	6.47	13.58	2.10	6.47	9.88	2.41	4.10	7.99	2.55	3.13	7.99	2.10	3.80	7.99	2.10	3.80
	-2	14.11	2.17	6.49	14.11	2.17	6.49	10.06	2.58	3.90	8.19	2.66	3.08	4.75	2.20	2.16	4.75	2.20	2.16
	0	14.57	2.24	6.52	14.31	2.26	6.34	10.18	2.64	3.86	8.04	2.75	2.92	4.85	2.27	2.14	4.85	2.27	2.14
	2	14.81	2.30	6.44	14.45	2.33	6.20	10.32	2.68	3.85	8.44	2.78	3.04	4.95	2.37	2.09	4.95	2.37	2.09
	5	15.96	2.44	6.55	15.81	2.52	6.28	11.33	2.86	3.96	9.18	2.93	3.13	4.70	2.50	1.88	4.70	2.50	1.88
	7	16.92	2.66	6.37	16.06	2.79	5.75	11.94	3.13	3.81	9.46	3.23	2.93	5.20	2.61	1.99	5.20	2.61	1.99
	10	17.21	2.90	5.94	15.86	3.06	5.18	12.11	3.22	3.76	9.30	3.39	2.74	5.50	2.77	1.99	5.50	2.77	1.99
	12	18.17	2.96	6.14	16.03	3.14	5.11	12.01	3.40	3.53	9.84	3.68	2.67	5.70	2.87	1.98	5.70	2.87	1.98
	15	16.91	3.12	5.42	16.24	3.28	4.95	12.18	3.70	3.29	9.81	4.00	2.45	6.10					

Table 2-6.5: 16kW heating capacity (continued)

LWT	DB	Maximum			100% (Normal)			75%			50%			25%			Minimum		
		HC	COP	PI	HC	COP	PI	HC	COP	PI	HC	COP	PI	HC	COP	PI	HC	COP	PI
65	-25	/	/	/	/	/	/	/	/	/	/	/	/	/	/	/	/	/	/
	-20	10.21	1.63	6.25	10.21	1.63	6.25	9.74	1.65	5.90	6.56	1.80	3.64	4.87	1.70	2.86	4.87	1.70	2.86
	-15	11.18	1.67	6.69	11.18	1.67	6.69	9.80	1.90	5.16	6.56	2.01	3.26	5.97	1.75	3.41	5.97	1.75	3.41
	-10	12.54	1.91	6.55	11.80	2.00	5.90	9.77	2.09	4.67	6.75	2.24	3.01	6.75	1.80	3.75	6.75	1.80	3.75
	-7	12.67	2.02	6.27	12.67	2.02	6.27	9.83	2.14	4.59	7.21	2.33	3.09	7.21	1.85	3.90	7.21	1.85	3.90
	-5	12.65	2.04	6.20	12.65	2.04	6.20	9.86	2.19	4.50	7.67	2.43	3.16	7.67	1.95	3.93	7.67	1.95	3.93
	-2	13.15	2.11	6.23	13.15	2.11	6.23	10.04	2.27	4.42	7.87	2.49	3.16	4.59	2.03	2.27	4.59	2.03	2.27
	0	13.50	2.17	6.22	13.50	2.17	6.22	10.24	2.33	4.39	8.36	2.55	3.28	4.69	2.09	2.24	4.69	2.09	2.24
	2	13.73	2.24	6.13	13.73	2.24	6.13	10.33	2.40	4.30	8.85	2.62	3.38	4.79	2.18	2.20	4.79	2.18	2.20
	5	15.59	2.40	6.50	15.59	2.40	6.50	11.21	2.70	4.15	8.83	2.91	3.03	4.50	2.31	1.95	4.50	2.31	1.95
	7	16.13	2.75	5.87	16.13	2.75	5.87	11.90	2.86	4.16	9.04	2.93	3.09	4.65	2.41	1.93	4.65	2.41	1.93
	10	16.26	2.78	5.85	16.04	2.80	5.71	11.88	2.98	3.99	8.93	3.24	2.76	4.90	2.56	1.91	4.90	2.56	1.91
	12	16.69	2.84	5.88	15.98	2.87	5.57	11.80	3.05	3.87	9.45	3.30	2.86	5.10	2.68	1.90	5.10	2.68	1.90
	15	16.39	2.88	5.69	15.75	2.94	5.36	11.93	3.25	3.67	9.42	3.59	2.62	5.45	2.86	1.90	5.45	2.86	1.90
	20	14.92	3.15	4.74	14.92	3.15	4.74	11.99	3.50	3.43	8.27	3.87	2.14	5.95	3.00	1.98	5.95	3.00	1.98
	25	14.81	3.40	4.36	14.81	3.40	4.36	12.14	3.69	3.29	9.14	3.98	2.30	6.50	3.30	1.97	6.50	3.30	1.97
	30	14.36	3.78	3.80	14.36	3.78	3.80	12.04	3.98	3.03	9.96	4.26	2.34	7.20	3.50	2.06	7.20	3.50	2.06
35	/	/	/	/	/	/	/	/	/	/	/	/	/	/	/	/	/	/	
70	-25	/	/	/	/	/	/	/	/	/	/	/	/	/	/	/	/	/	/
	-20	9.60	1.44	6.67	9.60	1.44	6.67	9.60	1.44	6.67	6.54	1.75	3.74	4.66	1.55	3.01	4.66	1.55	3.01
	-15	10.45	1.56	6.70	10.45	1.56	6.70	9.76	1.88	5.19	6.53	1.95	3.35	5.61	1.60	3.51	5.61	1.60	3.51
	-10	11.13	1.66	6.70	11.13	1.66	6.70	9.71	1.90	5.11	6.51	2.03	3.21	6.31	1.65	3.82	6.31	1.65	3.82
	-7	11.45	1.76	6.51	11.45	1.76	6.50	9.79	1.93	5.07	6.96	2.12	3.28	6.96	1.70	4.09	6.96	1.70	4.09
	-5	11.55	1.88	6.14	11.55	1.88	6.14	9.83	1.98	4.96	7.42	2.20	3.37	7.42	1.75	4.24	7.42	1.75	4.24
	-2	12.08	1.91	6.32	12.08	1.91	6.33	10.02	2.01	4.99	7.61	2.28	3.34	4.43	1.85	2.39	4.43	1.85	2.39
	0	12.33	1.93	6.39	12.33	1.93	6.39	10.19	2.03	5.02	8.08	2.33	3.47	4.53	1.91	2.37	4.53	1.91	2.37
	2	12.72	1.98	6.42	12.72	1.98	6.43	10.34	2.08	4.97	8.80	2.38	3.70	4.63	1.99	2.33	4.63	1.99	2.33
	5	14.00	2.09	6.70	14.00	2.09	6.70	11.26	2.45	4.60	8.81	2.75	3.20	4.81	2.11	2.28	4.81	2.11	2.28
	7	15.39	2.30	6.69	15.39	2.30	6.69	12.04	2.55	4.72	8.62	2.87	3.00	4.99	2.20	2.27	4.99	2.20	2.27
	10	15.06	2.50	6.02	15.06	2.50	6.01	11.99	2.64	4.53	8.94	3.00	2.98	5.25	2.36	2.23	5.25	2.36	2.23
	12	15.67	2.59	6.05	15.67	2.59	6.05	11.91	2.85	4.18	9.45	3.08	3.07	5.45	2.49	2.19	5.45	2.49	2.19
	15	15.67	2.72	5.76	15.67	2.72	5.76	12.05	2.93	4.11	9.40	3.33	2.82	5.76	2.69	2.14	5.76	2.69	2.14
	20	13.81	3.10	4.45	13.81	3.10	4.45	12.22	3.21	3.81	8.24	3.58	2.30	6.00	2.92	2.05	6.00	2.92	2.05
	25	14.00	3.24	4.32	14.00	3.24	4.32	12.29	3.40	3.61	9.11	3.73	2.44	6.20	3.10	2.00	6.20	3.10	2.00
	30	/	/	/	/	/	/	/	/	/	/	/	/	/	/	/	/	/	/
35	/	/	/	/	/	/	/	/	/	/	/	/	/	/	/	/	/	/	
75	-25	/	/	/	/	/	/	/	/	/	/	/	/	/	/	/	/	/	/
	-20	/	/	/	/	/	/	/	/	/	/	/	/	/	/	/	/	/	/
	-15	9.85	1.47	6.70	9.85	1.47	6.70	9.85	1.47	6.70	6.49	1.88	3.45	5.29	1.35	3.92	5.29	1.35	3.92
	-10	10.12	1.51	6.70	10.12	1.51	6.70	9.77	1.66	5.89	6.50	1.93	3.37	5.93	1.45	4.09	5.93	1.45	4.09
	-7	10.25	1.67	6.14	10.25	1.67	6.14	9.79	1.80	5.44	6.60	2.07	3.19	6.60	1.50	4.40	6.60	1.50	4.40
	-5	10.42	1.80	5.79	10.42	1.80	5.79	9.83	1.87	5.26	7.05	2.12	3.33	7.05	1.55	4.55	7.05	1.55	4.55
	-2	10.97	1.85	5.93	10.97	1.85	5.93	10.02	1.91	5.25	7.23	2.20	3.29	4.26	1.68	2.54	4.26	1.68	2.54
	0	11.48	1.90	6.04	11.48	1.90	6.04	10.19	2.00	5.10	7.69	2.28	3.37	4.36	1.73	2.52	4.36	1.73	2.52
	2	11.69	1.95	5.99	11.69	1.95	6.00	10.34	2.05	5.05	8.48	2.33	3.64	4.46	1.79	2.49	4.46	1.79	2.49
	5	13.40	2.03	6.60	13.40	2.03	6.60	11.26	2.20	5.12	8.50	2.48	3.43	4.63	1.92	2.42	4.63	1.92	2.42
	7	13.38	2.10	6.37	13.38	2.10	6.37	12.04	2.26	5.33	8.13	2.56	3.18	4.80	2.00	2.40	4.80	2.00	2.40
	10	13.58	2.25	6.04	13.58	2.25	6.04	11.99	2.33	5.15	8.63	2.69	3.21	5.03	2.15	2.34	5.03	2.15	2.34
	12	14.34	2.34	6.13	14.34	2.34	6.13	11.91	2.41	4.94	9.14	2.72	3.36	5.23	2.29	2.28	5.23	2.29	2.28
	15	14.20	2.37	5.99	14.20	2.37	5.99	12.05	2.45	4.92	9.12	2.83	3.22	5.53	2.52	2.19	5.53	2.52	2.19
	20	12.38	2.52	4.91	12.38	2.52	4.91	12.38	2.52	4.91	7.99	3.00	2.66	5.80	2.70	2.15	5.80	2.70	2.15
	25	/	/	/	/	/	/	/	/	/	/	/	/	/	/	/	/	/	/
	30	/	/	/	/	/	/	/	/	/	/	/	/	/	/	/	/	/	/
35	/	/	/	/	/	/	/	/	/	/	/	/	/	/	/	/	/	/	
80	-25	/	/	/	/	/	/	/	/	/	/	/	/	/	/	/	/	/	/
	-20	/	/	/	/	/	/	/	/	/	/	/	/	/	/	/	/	/	/
	-15	/	/	/	/	/	/	/	/	/	/	/	/	/	/	/	/	/	/
	-10	8.04	1.20	6.70	8.04	1.20	6.70	8.04	1.20	6.70	6.50	1.35	4.81	5.77	1.30	4.44	5.77	1.30	4.44
	-7	9.25	1.38	6.70	9.25	1.38	6.70	9.25	1.38	6.70	6.45	1.69	3.81	6.14	1.50	4.09	6.14	1.50	4.09
	-5	9.89	1.53	6.46	9.89	1.53	6.46	9.89	1.53	6.46	6.59	1.95	3.38	6.59	1.40	4.71	6.59	1.40	4.71
	-2	9.98	1.54	6.48	9.98	1.54	6.48	9.98	1.54	6.48	6.75	1.98	3.41	4.10	1.50	2.73	4.10	1.50	2.73
	0	10.34	1.56	6.63	10.34	1.56	6.63	10.34	1.56	6.63	7.20	2.05	3.51	4.20	1.55	2.71	4.20	1.55	2.71
	2	10.37	1.62	6.40	10.37	1.62	6.42	10.37	1.62	6.42	8.02	2.08	3.85	4.30	1.60	2.69	4.30	1.60	2.69
	5	12.16	1.84	6.61	12.16	1.84	6.60	11.16	1.93	5.78	8.16	2.12	3.85	4.45	1.72	2.59	4.45	1.72	2.59
	7	12.15	1.96	6.20	12.15	1.96	6.20	12.15	1.96	6.20	8.26	2.26	3.65	4.60	1.80	2.56	4.60	1.80	2.56
	10	12.30	2.03	6.06	12.30	2.03	6.07	12.00	2.07	5.80	8.14	2.33	3.49	4.81	1.95	2.47	4.81	1.95	2.47
	12	12.68	2.12	5.98	12.68	2.12	6.00	12.05	2.17	5.55	8.62	2.44	3.53	5.00	2.10	2.38	5.00	2.10	2.38
	15	12.80	2.24	5.71	12.80	2.24	5.71	12.17	2.30	5.29	8.62	2.53	3.41	5.30	2.35	2.26	5.30	2.35	2.26
	20	/	/	/	/	/	/	/	/	/	/	/	/	/	/	/	/	/	/
	25	/	/	/	/	/	/	/	/	/	/	/	/	/	/	/	/	/	/
	30	/	/	/	/	/	/	/	/	/	/	/	/	/	/	/	/	/	/
35	/	/	/	/	/	/	/	/	/	/	/	/	/	/	/	/	/	/	

Abbreviations:

LWT: Leaving water temperature (°C)

DB: Dry-bulb temperature for outdoor air temperature (°C)

HC: Total heating capacity (kW)

PI: Power input (kW)

R290 M thermal Nature Plus Series



6.2 Cooling Capacity Tables (Test standard: EN14511)

Table 2-6.6: 8kW cooling capacity

LWT	DB	Maximum			100% (Normal)			75%			50%			25%			Minimum		
		CC	EER	PI	CC	EER	PI	CC	EER	PI	CC	EER	PI	CC	EER	PI	CC	EER	PI
5	-5	/	/	/	/	/	/	/	/	/	/	/	/	/	/	/	/	/	/
	0	/	/	/	/	/	/	/	/	/	/	/	/	/	/	/	/	/	/
	5	/	/	/	/	/	/	/	/	/	/	/	/	/	/	/	/	/	/
	10	/	/	/	/	/	/	/	/	/	/	/	/	/	/	/	/	/	/
	15	/	/	/	/	/	/	/	/	/	/	/	/	/	/	/	/	/	/
	19	6.70	5.24	1.28	6.70	5.24	1.28	5.58	5.42	1.03	3.77	5.72	0.66	3.15	5.83	0.54	3.15	5.83	0.54
	20	6.71	5.01	1.34	6.71	5.01	1.34	5.69	5.18	1.10	3.74	5.51	0.68	3.13	5.61	0.56	3.13	5.61	0.56
	25	6.88	4.24	1.62	6.88	4.24	1.62	5.60	4.45	1.26	3.75	4.76	0.79	3.04	4.88	0.62	3.04	4.88	0.62
	30	7.30	3.50	2.09	7.30	3.50	2.09	5.54	3.79	1.46	3.77	4.08	0.92	2.90	4.23	0.69	2.90	4.23	0.69
	35	7.40	2.98	2.48	7.40	2.98	2.48	5.59	3.28	1.70	3.72	3.60	1.03	2.75	3.76	0.73	2.75	3.76	0.73
	40	6.99	2.65	2.64	6.99	2.65	2.64	5.54	2.89	1.92	3.76	3.18	1.18	2.59	3.38	0.77	2.59	3.38	0.77
	43	6.78	2.43	2.79	6.78	2.43	2.79	5.55	2.64	2.10	3.74	2.94	1.27	2.48	3.15	0.79	2.48	3.15	0.79
46	6.18	2.16	2.86	6.18	2.16	2.86	5.50	2.27	2.42	3.83	2.55	1.50	2.37	2.80	0.85	2.37	2.80	0.85	
7	-5	/	/	/	/	/	/	/	/	/	/	/	/	/	/	/	/	/	/
	0	/	/	/	/	/	/	/	/	/	/	/	/	/	/	/	/	/	/
	5	/	/	/	/	/	/	/	/	/	/	/	/	/	/	/	/	/	/
	10	/	/	/	/	/	/	/	/	/	/	/	/	/	/	/	/	/	/
	15	/	/	/	/	/	/	/	/	/	/	/	/	/	/	/	/	/	/
	19	7.15	5.70	1.25	7.15	5.70	1.25	5.62	5.95	0.94	3.78	6.26	0.60	3.38	6.32	0.53	3.38	6.32	0.53
	20	7.17	5.35	1.34	7.17	5.35	1.34	5.58	5.62	0.99	3.75	5.92	0.63	3.36	5.99	0.56	3.36	5.99	0.56
	25	7.36	4.49	1.64	7.36	4.49	1.64	5.66	4.77	1.19	3.74	5.09	0.73	3.27	5.17	0.63	3.27	5.17	0.63
	30	7.80	3.91	1.99	7.48	4.08	1.83	5.62	4.39	1.28	3.74	4.70	0.80	3.12	4.81	0.65	3.12	4.81	0.65
	35	7.88	3.26	2.42	7.45	3.35	2.22	5.53	3.72	1.49	3.71	4.02	0.92	2.97	4.15	0.72	2.97	4.15	0.72
	40	7.45	2.75	2.71	7.45	2.75	2.71	5.59	3.06	1.83	3.77	3.38	1.12	2.80	3.54	0.79	2.80	3.54	0.79
	43	7.23	2.57	2.81	7.23	2.57	2.81	5.59	2.84	1.97	3.76	3.14	1.20	2.69	3.32	0.81	2.69	3.32	0.81
46	6.52	2.43	2.68	6.52	2.43	2.68	5.54	2.59	2.14	3.73	2.90	1.29	2.57	3.09	0.83	2.57	3.09	0.83	
10	-5	/	/	/	/	/	/	/	/	/	/	/	/	/	/	/	/	/	/
	0	/	/	/	/	/	/	/	/	/	/	/	/	/	/	/	/	/	/
	5	/	/	/	/	/	/	/	/	/	/	/	/	/	/	/	/	/	/
	10	/	/	/	/	/	/	/	/	/	/	/	/	/	/	/	/	/	/
	15	7.42	7.00	1.06	7.42	7.00	1.06	5.91	7.25	0.82	3.81	7.60	0.50	3.81	7.60	0.50	3.81	7.60	0.50
	19	7.88	6.30	1.25	7.71	6.33	1.22	5.83	6.65	0.88	3.75	6.99	0.54	3.75	6.99	0.54	3.75	6.99	0.54
	20	7.90	5.91	1.34	7.65	5.96	1.28	5.79	6.27	0.92	3.72	6.61	0.56	3.72	6.61	0.56	3.72	6.61	0.56
	25	8.10	4.89	1.66	7.64	4.98	1.53	5.90	5.27	1.12	3.60	5.65	0.64	3.60	5.65	0.64	3.60	5.65	0.64
	30	8.58	4.09	2.10	7.66	4.27	1.79	5.68	4.60	1.23	3.47	4.97	0.70	3.47	4.97	0.70	3.47	4.97	0.70
	35	8.56	3.40	2.52	7.61	3.64	2.09	5.77	3.95	1.46	3.29	4.36	0.75	3.29	4.36	0.75	3.29	4.36	0.75
	40	8.19	2.97	2.76	7.69	3.07	2.50	5.79	3.39	1.71	3.10	3.84	0.81	3.10	3.84	0.81	3.10	3.84	0.81
	43	7.94	2.76	2.88	7.75	2.80	2.77	5.73	3.13	1.83	2.98	3.59	0.83	2.98	3.59	0.83	2.98	3.59	0.83
46	7.08	2.54	2.79	7.08	2.54	2.79	5.80	2.75	2.11	2.86	3.24	0.88	2.86	3.24	0.88	2.86	3.24	0.88	
11	-5	/	/	/	/	/	/	/	/	/	/	/	/	/	/	/	/	/	/
	0	/	/	/	/	/	/	/	/	/	/	/	/	/	/	/	/	/	/
	5	/	/	/	/	/	/	/	/	/	/	/	/	/	/	/	/	/	/
	10	6.46	8.15	0.79	6.46	8.15	0.79	5.77	8.26	0.70	4.96	8.40	0.59	4.96	8.40	0.59	4.96	8.40	0.59
	15	7.67	7.36	1.04	7.67	7.36	1.04	5.91	7.65	0.77	3.94	7.98	0.49	3.94	7.98	0.49	3.94	7.98	0.49
	19	8.14	6.48	1.26	7.78	6.55	1.19	5.81	6.88	0.84	3.87	7.20	0.54	3.87	7.20	0.54	3.87	7.20	0.54
	20	8.14	6.11	1.33	7.71	6.19	1.25	5.79	6.51	0.89	3.85	6.84	0.56	3.85	6.84	0.56	3.85	6.84	0.56
	25	8.37	5.09	1.64	7.71	5.22	1.48	5.91	5.52	1.07	3.72	5.89	0.63	3.72	5.89	0.63	3.72	5.89	0.63
	30	8.74	4.20	2.08	7.77	4.39	1.77	5.87	4.71	1.25	3.59	5.09	0.71	3.59	5.09	0.71	3.59	5.09	0.71
	35	8.93	3.61	2.47	7.74	3.85	2.01	5.79	4.18	1.39	3.40	4.58	0.74	3.40	4.58	0.74	3.40	4.58	0.74
	40	8.44	3.05	2.77	7.73	3.19	2.42	5.83	3.51	1.66	3.21	3.95	0.81	3.21	3.95	0.81	3.21	3.95	0.81
	43	8.20	2.83	2.90	7.74	2.92	2.65	5.77	3.25	1.78	3.09	3.69	0.84	3.09	3.69	0.84	3.09	3.69	0.84
46	7.31	2.74	2.67	7.31	2.74	2.67	5.99	2.96	2.02	2.96	3.47	0.85	2.96	3.47	0.85	2.96	3.47	0.85	
15	-5	5.79	7.61	0.76	5.79	7.61	0.76	5.55	7.64	0.73	5.31	7.67	0.69	5.31	7.67	0.69	5.31	7.67	0.69
	0	6.31	7.40	0.85	6.31	7.40	0.85	5.74	7.43	0.77	5.43	7.48	0.73	5.43	7.48	0.73	5.43	7.48	0.73
	5	6.83	7.16	0.95	6.83	7.16	0.95	5.93	7.19	0.82	5.55	7.23	0.77	5.55	7.23	0.77	5.55	7.23	0.77
	10	7.35	6.89	1.07	7.35	6.89	1.07	6.12	7.08	0.86	5.67	7.10	0.80	5.67	7.10	0.80	5.67	7.10	0.80
	15	8.67	6.65	1.30	8.23	6.72	1.22	6.02	6.86	0.88	4.48	6.96	0.64	4.48	6.96	0.64	4.48	6.96	0.64
	19	9.21	6.24	1.48	8.12	6.30	1.29	6.17	6.45	0.96	4.41	6.61	0.67	4.41	6.61	0.67	4.41	6.61	0.67
	20	9.22	5.68	1.62	8.05	5.88	1.37	6.12	6.16	0.99	4.39	6.41	0.68	4.39	6.41	0.68	4.39	6.41	0.68
	25	9.47	4.97	1.91	8.10	5.20	1.56	6.11	5.50	1.11	4.23	5.77	0.73	4.23	5.77	0.73	4.23	5.77	0.73
	30	10.00	4.32	2.31	8.10	4.65	1.74	6.10	4.92	1.24	4.09	5.24	0.78	4.09	5.24	0.78	4.09	5.24	0.78
	35	10.08	3.70	2.72	8.09	3.98	2.03	6.19	4.27	1.45	3.88	4.71	0.82	3.88	4.71	0.82	3.88	4.71	0.82
	40	9.42	3.12	3.02	8.03	3.38	2.38	6.07	3.67	1.65	3.67	4.04	0.91	3.67	4.04	0.91	3.67	4.04	0.91
	43	9.36	2.86	3.27	7.97	3.10	2.57	6.04	3.39	1.78	3.54	3.79	0.93	3.54	3.79	0.93	3.54	3.79	0.93
46	8.06	2.83	2.85	8.06	2.83	2.85	6.14	3.13	1.96	3.39	3.56	0.95	3.39	3.56	0.95	3.39	3.56	0.95	

Abbreviations:

LWT: Leaving water temperature (°C)

DB: Dry-bulb temperature for outdoor air temperature (°C)

CC: Total cooling capacity (kW)

PI: Power input (kW)

Table continued on next page ...

Table 2-6.6: 8kW cooling capacity (continued)

LWT	DB	Maximum			100% (Normal)			75%			50%			25%			Minimum		
		CC	EER	PI	CC	EER	PI	CC	EER	PI	CC	EER	PI	CC	EER	PI	CC	EER	PI
18	-5	6.28	7.94	0.79	6.28	7.94	0.79	6.04	7.97	0.76	5.80	8.00	0.73	5.80	8.00	0.73	5.80	8.00	0.73
	0	6.87	7.71	0.89	6.87	7.71	0.89	6.10	7.74	0.79	5.94	7.77	0.76	5.94	7.77	0.76	5.94	7.77	0.76
	5	7.46	7.48	1.00	7.46	7.48	1.00	6.16	7.58	0.81	6.08	7.60	0.80	6.08	7.60	0.80	6.08	7.60	0.80
	10	8.05	7.24	1.11	8.05	7.24	1.11	6.22	7.48	0.83	6.22	7.48	0.83	6.22	7.48	0.83	6.22	7.48	0.83
	15	9.47	6.85	1.38	8.26	6.93	1.19	6.17	7.14	0.86	4.92	7.30	0.67	4.92	7.30	0.67	4.92	7.30	0.67
	19	9.96	6.75	1.48	8.46	6.78	1.25	6.34	7.07	0.90	4.86	7.27	0.67	4.86	7.27	0.67	4.86	7.27	0.67
	20	9.99	6.30	1.59	8.39	6.57	1.28	6.29	6.87	0.92	4.83	7.08	0.68	4.83	7.08	0.68	4.83	7.08	0.68
	25	10.35	5.64	1.84	8.23	6.00	1.37	6.28	6.29	1.00	4.65	6.53	0.71	4.65	6.53	0.71	4.65	6.53	0.71
	30	10.93	5.01	2.18	8.20	5.54	1.48	6.30	5.82	1.08	4.50	6.08	0.74	4.50	6.08	0.74	4.50	6.08	0.74
	35	11.01	4.48	2.46	8.30	5.25	1.58	6.20	5.48	1.13	4.27	5.66	0.75	4.27	5.66	0.75	4.27	5.66	0.75
	40	10.43	3.59	2.91	8.34	3.97	2.10	6.28	4.40	1.43	4.06	4.73	0.86	4.06	4.73	0.86	4.06	4.73	0.86
	43	9.72	3.14	3.10	8.26	3.41	2.42	6.26	3.73	1.68	3.91	4.09	0.96	3.91	4.09	0.96	3.91	4.09	0.96
	46	8.69	3.06	2.84	8.23	3.15	2.61	6.39	3.44	1.86	3.75	3.85	0.97	3.75	3.85	0.97	3.75	3.85	0.97
	20	-5	6.35	8.01	0.79	6.35	8.01	0.79	6.11	8.04	0.76	5.87	8.07	0.73	5.87	8.07	0.73	5.87	8.07
0		7.08	7.78	0.91	6.99	7.79	0.90	6.28	7.85	0.80	6.12	7.86	0.78	6.12	7.86	0.78	6.12	7.86	0.78
5		7.81	7.54	1.04	7.64	7.56	1.01	6.44	7.65	0.84	6.36	7.67	0.83	6.36	7.67	0.83	6.36	7.67	0.83
10		8.54	7.13	1.20	8.28	7.17	1.15	6.61	7.45	0.89	6.61	7.45	0.89	6.61	7.45	0.89	6.61	7.45	0.89
15		9.93	7.05	1.41	8.28	7.11	1.16	6.31	7.21	0.88	5.24	7.34	0.71	5.24	7.34	0.71	5.24	7.34	0.71
19		10.69	6.85	1.56	8.47	6.96	1.22	6.25	7.11	0.88	5.17	7.20	0.72	5.17	7.20	0.72	5.17	7.20	0.72
20		10.70	6.67	1.60	8.41	6.87	1.22	6.21	6.99	0.89	5.14	7.13	0.72	5.14	7.13	0.72	5.14	7.13	0.72
25		10.94	6.32	1.73	8.30	6.79	1.22	6.20	6.85	0.91	4.95	7.02	0.71	4.95	7.02	0.71	4.95	7.02	0.71
30		11.55	5.54	2.08	8.23	6.10	1.35	6.24	6.39	0.98	4.79	6.60	0.73	4.79	6.60	0.73	4.79	6.60	0.73
35		11.66	4.78	2.44	8.28	5.34	1.55	6.18	5.60	1.10	4.56	5.89	0.77	4.56	5.89	0.77	4.56	5.89	0.77
40		11.05	3.82	2.89	8.30	4.22	1.97	6.29	4.53	1.39	4.32	4.95	0.87	4.32	4.95	0.87	4.32	4.95	0.87
43		10.29	3.35	3.07	8.35	3.70	2.26	6.26	4.03	1.55	4.17	4.35	0.96	4.17	4.35	0.96	4.17	4.35	0.96
46		9.18	3.21	2.86	8.30	3.37	2.46	6.23	3.69	1.69	4.01	4.04	0.99	4.01	4.04	0.99	4.01	4.04	0.99
25		-5	6.52	8.18	0.80	6.52	8.18	0.80	6.28	8.21	0.76	6.04	8.24	0.73	6.04	8.24	0.73	6.04	8.24
	0	7.64	7.93	0.96	7.13	7.95	0.90	6.74	7.98	0.84	6.58	8.01	0.82	6.58	8.01	0.82	6.58	8.01	0.82
	5	8.75	7.64	1.15	7.73	7.68	1.01	7.21	7.73	0.93	7.13	7.76	0.92	7.13	7.76	0.92	7.13	7.76	0.92
	10	9.87	7.49	1.32	8.34	7.58	1.10	7.67	7.64	1.00	7.67	7.64	1.00	7.67	7.64	1.00	7.67	7.64	1.00
	15	11.55	7.14	1.62	8.43	7.27	1.16	6.15	7.41	0.83	6.06	7.42	0.82	6.06	7.42	0.82	6.06	7.42	0.82
	19	12.34	7.03	1.76	8.37	7.20	1.16	6.32	7.34	0.86	6.02	7.37	0.82	6.02	7.37	0.82	6.02	7.37	0.82
	20	12.35	6.75	1.83	8.31	7.06	1.18	6.30	7.20	0.88	5.98	7.24	0.83	5.98	7.24	0.83	5.98	7.24	0.83
	25	12.61	6.59	1.91	8.28	6.69	1.24	6.28	6.87	0.91	5.77	6.95	0.83	5.77	6.95	0.83	5.77	6.95	0.83
	30	13.32	5.84	2.28	8.27	6.30	1.31	6.32	6.54	0.97	5.59	6.64	0.84	5.59	6.64	0.84	5.59	6.64	0.84
	35	13.41	5.08	2.64	8.39	5.84	1.44	6.26	6.15	1.02	5.32	6.29	0.85	5.32	6.29	0.85	5.32	6.29	0.85
	40	12.70	4.46	2.85	8.45	5.11	1.65	6.16	5.46	1.13	5.04	5.63	0.90	5.04	5.63	0.90	5.04	5.63	0.90
	43	11.58	4.25	2.72	8.37	4.71	1.78	6.17	5.05	1.22	4.87	5.25	0.93	4.87	5.25	0.93	4.87	5.25	0.93
	46	10.46	3.67	2.85	8.27	4.07	2.03	6.37	4.37	1.46	4.69	4.63	1.01	4.69	4.63	1.01	4.69	4.63	1.01

Abbreviations:

LWT: Leaving water temperature (°C)

DB: Dry-bulb temperature for outdoor air temperature (°C)

CC: Total cooling capacity (kW)

PI: Power input (kW)

R290 M thermal Nature Plus Series



Table 2-6.7: 10kW cooling capacity

LWT	DB	Maximum			100% (Normal)			75%			50%			25%			Minimum		
		CC	EER	PI	CC	EER	PI	CC	EER	PI	CC	EER	PI	CC	EER	PI	CC	EER	PI
5	-5	/	/	/	/	/	/	/	/	/	/	/	/	/	/	/	/	/	/
	0	/	/	/	/	/	/	/	/	/	/	/	/	/	/	/	/	/	/
	5	/	/	/	/	/	/	/	/	/	/	/	/	/	/	/	/	/	/
	10	/	/	/	/	/	/	/	/	/	/	/	/	/	/	/	/	/	/
	15	/	/	/	/	/	/	/	/	/	/	/	/	/	/	/	/	/	/
	19	6.91	5.21	1.33	6.91	5.21	1.33	6.08	5.31	1.15	4.08	5.67	0.72	3.15	5.83	0.54	3.15	5.83	0.54
	20	6.96	4.98	1.40	6.96	4.98	1.40	6.02	5.10	1.18	4.05	5.45	0.74	3.13	5.61	0.56	3.13	5.61	0.56
	25	7.36	4.18	1.76	7.36	4.18	1.76	6.06	4.34	1.40	4.05	4.71	0.86	3.04	4.88	0.62	3.04	4.88	0.62
	30	7.90	3.42	2.31	7.90	3.42	2.31	6.06	3.65	1.66	4.04	4.04	1.00	2.90	4.23	0.69	2.90	4.23	0.69
	35	7.98	2.91	2.74	7.98	2.91	2.74	6.04	3.15	1.92	4.10	3.53	1.16	2.75	3.76	0.73	2.75	3.76	0.73
7	-5	/	/	/	/	/	/	/	/	/	/	/	/	/	/	/	/	/	/
	0	/	/	/	/	/	/	/	/	/	/	/	/	/	/	/	/	/	/
	5	/	/	/	/	/	/	/	/	/	/	/	/	/	/	/	/	/	/
	10	/	/	/	/	/	/	/	/	/	/	/	/	/	/	/	/	/	/
	15	/	/	/	/	/	/	/	/	/	/	/	/	/	/	/	/	/	/
	19	7.36	5.67	1.30	7.36	5.67	1.30	6.15	5.82	1.06	4.04	6.21	0.65	3.38	6.32	0.53	3.38	6.32	0.53
	20	7.44	5.32	1.40	7.44	5.32	1.40	6.10	5.49	1.11	4.17	5.85	0.71	3.36	5.99	0.56	3.36	5.99	0.56
	25	7.85	4.43	1.77	7.85	4.43	1.77	6.15	4.64	1.33	4.02	5.05	0.80	3.27	5.17	0.63	3.27	5.17	0.63
	30	8.41	3.82	2.20	8.10	3.88	2.09	6.09	4.21	1.45	4.04	4.65	0.87	3.12	4.81	0.65	3.12	4.81	0.65
	35	8.49	3.07	2.77	8.10	3.10	2.61	6.06	3.50	1.73	4.12	3.96	1.04	2.97	4.15	0.72	2.97	4.15	0.72
10	-5	/	/	/	/	/	/	/	/	/	/	/	/	/	/	/	/	/	/
	0	/	/	/	/	/	/	/	/	/	/	/	/	/	/	/	/	/	/
	5	/	/	/	/	/	/	/	/	/	/	/	/	/	/	/	/	/	/
	10	/	/	/	/	/	/	/	/	/	/	/	/	/	/	/	/	/	/
	15	7.71	6.96	1.11	7.71	6.96	1.11	6.45	7.12	0.91	4.24	7.53	0.56	3.81	7.60	0.50	3.81	7.60	0.50
	19	8.11	6.27	1.29	8.11	6.27	1.29	6.58	6.47	1.02	4.32	6.90	0.63	3.75	6.99	0.54	3.75	6.99	0.54
	20	8.19	5.87	1.40	8.19	5.87	1.40	6.53	6.10	1.07	4.29	6.52	0.66	3.72	6.61	0.56	3.72	6.61	0.56
	25	8.63	4.82	1.79	8.63	4.82	1.79	6.43	5.13	1.25	4.28	5.54	0.77	3.60	5.65	0.64	3.60	5.65	0.64
	30	9.24	3.97	2.33	8.58	4.09	2.10	6.55	4.41	1.49	4.32	4.83	0.89	3.47	4.97	0.70	3.47	4.97	0.70
	35	9.32	3.27	2.85	8.56	3.40	2.52	6.41	3.79	1.69	4.26	4.20	1.01	3.29	4.36	0.75	3.29	4.36	0.75
11	-5	/	/	/	/	/	/	/	/	/	/	/	/	/	/	/	/	/	/
	0	/	/	/	/	/	/	/	/	/	/	/	/	/	/	/	/	/	/
	5	/	/	/	/	/	/	/	/	/	/	/	/	/	/	/	/	/	/
	10	6.67	8.12	0.82	6.67	8.12	0.82	6.67	8.12	0.82	4.96	8.40	0.59	4.96	8.40	0.59	4.96	8.40	0.59
	15	7.95	7.32	1.09	7.95	7.32	1.09	6.66	7.49	0.89	4.38	7.91	0.55	3.94	7.98	0.49	3.94	7.98	0.49
	19	8.37	6.45	1.30	8.37	6.45	1.30	6.60	6.70	0.99	4.47	7.10	0.63	3.87	7.20	0.54	3.87	7.20	0.54
	20	8.45	6.07	1.39	8.45	6.07	1.39	6.55	6.34	1.03	4.44	6.74	0.66	3.85	6.84	0.56	3.85	6.84	0.56
	25	8.90	4.98	1.79	8.78	5.04	1.74	6.64	5.36	1.24	4.43	5.77	0.77	3.72	5.89	0.63	3.72	5.89	0.63
	30	9.52	4.07	2.34	8.74	4.20	2.08	6.59	4.54	1.45	4.46	4.95	0.90	3.59	5.09	0.71	3.59	5.09	0.71
	35	9.62	3.51	2.74	8.72	3.64	2.40	6.61	3.99	1.66	4.40	4.41	1.00	3.40	4.58	0.74	3.40	4.58	0.74
15	-5	6.03	7.58	0.80	6.03	7.58	0.80	5.79	7.61	0.76	5.55	7.64	0.73	5.31	7.67	0.69	5.31	7.67	0.69
	0	6.55	7.37	0.89	6.55	7.37	0.89	6.23	7.40	0.84	5.59	7.46	0.75	5.43	7.48	0.73	5.43	7.48	0.73
	5	7.07	7.14	0.99	7.07	7.14	0.99	6.68	7.17	0.93	5.63	7.22	0.78	5.55	7.23	0.77	5.55	7.23	0.77
	10	7.59	6.80	1.12	7.59	6.80	1.12	7.12	6.93	1.03	5.67	7.10	0.80	5.67	7.10	0.80	5.67	7.10	0.80
	15	9.03	6.61	1.37	9.03	6.61	1.37	7.09	6.76	1.05	4.65	6.94	0.67	4.48	6.96	0.64	4.48	6.96	0.64
	19	9.47	6.21	1.52	9.47	6.21	1.52	7.06	6.39	1.10	4.75	6.56	0.72	4.41	6.61	0.67	4.41	6.61	0.67
	20	9.55	5.62	1.70	9.47	5.65	1.68	7.22	5.97	1.21	4.72	6.36	0.74	4.39	6.41	0.68	4.39	6.41	0.68
	25	10.06	4.89	2.06	9.47	4.97	1.91	7.13	5.32	1.34	4.88	5.67	0.86	4.23	5.77	0.73	4.23	5.77	0.73
	30	10.74	4.13	2.60	9.47	4.38	2.16	7.07	4.76	1.49	4.73	5.15	0.92	4.09	5.24	0.78	4.09	5.24	0.78
	35	10.83	3.64	2.98	9.49	3.80	2.50	7.13	4.15	1.72	4.66	4.62	1.01	3.88	4.71	0.82	3.88	4.71	0.82

Abbreviations:

LWT: Leaving water temperature (°C)

DB: Dry-bulb temperature for outdoor air temperature (°C)

CC: Total cooling capacity (kW)

PI: Power input (kW)

Table continued on next page ...

Table 2-6.7: 10kW cooling capacity (continued)

LWT	DB	Maximum			100% (Normal)			75%			50%			25%			Minimum		
		CC	EER	PI	CC	EER	PI	CC	EER	PI	CC	EER	PI	CC	EER	PI	CC	EER	PI
18	-5	6.52	7.91	0.82	6.52	7.91	0.82	6.28	7.94	0.79	6.04	7.97	0.76	5.80	8.00	0.73	5.80	8.00	0.73
	0	7.11	7.69	0.92	7.11	7.69	0.92	6.67	7.72	0.86	6.10	7.74	0.79	5.94	7.77	0.76	5.94	7.77	0.76
	5	7.71	7.45	1.03	7.71	7.45	1.03	7.05	7.50	0.94	6.16	7.58	0.81	6.08	7.60	0.80	6.08	7.60	0.80
	10	8.30	7.22	1.15	8.30	7.22	1.15	7.44	7.30	1.02	6.22	7.48	0.83	6.22	7.48	0.83	6.22	7.48	0.83
	15	9.85	6.80	1.45	9.85	6.80	1.45	7.56	7.09	1.07	4.92	7.30	0.67	4.92	7.30	0.67	4.92	7.30	0.67
	19	10.38	6.68	1.55	9.96	6.75	1.48	7.50	6.88	1.09	5.05	7.24	0.70	4.86	7.27	0.67	4.86	7.27	0.67
	20	10.49	6.21	1.69	9.99	6.30	1.59	7.44	6.67	1.12	5.01	7.05	0.71	4.83	7.08	0.68	4.83	7.08	0.68
	25	10.99	5.59	1.97	9.94	5.68	1.75	7.59	6.07	1.25	5.01	6.47	0.77	4.65	6.53	0.71	4.65	6.53	0.71
	30	11.73	4.90	2.39	10.01	5.19	1.93	7.57	5.65	1.34	5.03	6.01	0.84	4.50	6.08	0.74	4.50	6.08	0.74
	35	11.86	4.35	2.73	10.00	4.60	2.17	7.42	5.31	1.40	4.96	5.56	0.89	4.27	5.66	0.75	4.27	5.66	0.75
	40	11.23	3.50	3.21	9.95	3.74	2.66	7.61	4.08	1.87	5.05	4.49	1.12	4.06	4.73	0.86	4.06	4.73	0.86
	43	10.09	3.09	3.27	9.98	3.12	3.20	7.56	3.50	2.16	5.06	3.92	1.29	3.91	4.09	0.96	3.91	4.09	0.96
	46	8.69	3.06	2.84	8.69	3.06	2.84	7.49	3.23	2.32	5.03	3.66	1.37	3.75	3.85	0.97	3.75	3.85	0.97
20	-5	6.59	7.98	0.83	6.59	7.98	0.83	6.35	8.01	0.79	6.11	8.04	0.76	5.87	8.07	0.73	5.87	8.07	0.73
	0	7.33	7.75	0.95	7.33	7.75	0.95	6.73	7.80	0.86	6.28	7.85	0.80	6.12	7.86	0.78	6.12	7.86	0.78
	5	8.06	7.52	1.07	8.06	7.52	1.07	7.11	7.58	0.94	6.44	7.65	0.84	6.36	7.67	0.83	6.36	7.67	0.83
	10	8.80	7.11	1.24	8.80	7.11	1.24	7.49	7.32	1.02	6.61	7.45	0.89	6.61	7.45	0.89	6.61	7.45	0.89
	15	10.45	6.99	1.49	9.93	7.05	1.41	7.54	7.20	1.05	5.24	7.34	0.71	5.24	7.34	0.71	5.24	7.34	0.71
	19	10.99	6.84	1.61	10.05	6.92	1.45	7.46	7.05	1.06	5.17	7.20	0.72	5.17	7.20	0.72	5.17	7.20	0.72
	20	11.08	6.65	1.67	10.08	6.73	1.50	7.67	6.94	1.11	5.14	7.13	0.72	5.14	7.13	0.72	5.14	7.13	0.72
	25	11.64	6.28	1.85	9.93	6.48	1.53	7.61	6.80	1.12	4.95	7.02	0.71	4.95	7.02	0.71	4.95	7.02	0.71
	30	12.42	5.46	2.27	9.97	5.76	1.73	7.57	6.17	1.23	4.98	6.57	0.76	4.79	6.60	0.73	4.79	6.60	0.73
	35	12.51	4.68	2.67	9.93	4.92	2.02	7.45	5.48	1.36	4.92	5.74	0.86	4.56	5.89	0.77	4.56	5.89	0.77
	40	11.71	3.75	3.12	10.01	3.98	2.52	7.50	4.51	1.66	5.01	4.73	1.06	4.32	4.95	0.87	4.32	4.95	0.87
	43	10.55	3.25	3.25	9.93	3.39	2.93	7.44	3.81	1.95	5.01	4.22	1.19	4.17	4.35	0.96	4.17	4.35	0.96
	46	9.18	3.21	2.86	9.18	3.21	2.86	7.53	3.46	2.18	5.00	3.89	1.29	4.01	4.04	0.99	4.01	4.04	0.99
25	-5	6.76	8.15	0.83	6.76	8.15	0.83	6.52	8.18	0.80	6.28	8.21	0.76	6.04	8.24	0.73	6.04	8.24	0.73
	0	7.89	7.91	1.00	7.89	7.91	1.00	6.90	7.95	0.87	6.74	7.98	0.84	6.58	8.01	0.82	6.58	8.01	0.82
	5	9.03	7.60	1.19	9.03	7.60	1.19	7.29	7.70	0.95	7.21	7.73	0.93	7.13	7.76	0.92	7.13	7.76	0.92
	10	10.16	7.47	1.36	10.16	7.47	1.36	7.67	7.64	1.00	7.67	7.64	1.00	7.67	7.64	1.00	7.67	7.64	1.00
	15	12.06	7.07	1.71	9.83	7.20	1.37	7.56	7.34	1.03	6.06	7.42	0.82	6.06	7.42	0.82	6.06	7.42	0.82
	19	12.68	6.94	1.83	10.02	7.14	1.40	7.54	7.27	1.04	6.02	7.37	0.82	6.02	7.37	0.82	6.02	7.37	0.82
	20	12.79	6.67	1.92	9.95	6.89	1.44	7.49	7.13	1.05	5.98	7.24	0.83	5.98	7.24	0.83	5.98	7.24	0.83
	25	13.38	6.39	2.09	10.08	6.65	1.52	7.46	6.77	1.10	5.77	6.95	0.83	5.77	6.95	0.83	5.77	6.95	0.83
	30	14.27	5.68	2.51	10.09	6.25	1.61	7.50	6.38	1.18	5.59	6.64	0.84	5.59	6.64	0.84	5.59	6.64	0.84
	35	14.34	4.92	2.91	10.09	5.50	1.83	7.42	5.95	1.25	5.32	6.29	0.85	5.32	6.29	0.85	5.32	6.29	0.85
	40	13.26	4.33	3.06	9.97	4.77	2.09	7.54	5.21	1.45	5.04	5.63	0.90	5.04	5.63	0.90	5.04	5.63	0.90
	43	11.85	4.13	2.87	9.96	4.44	2.24	7.49	4.81	1.56	5.07	5.22	0.97	4.87	5.25	0.93	4.87	5.25	0.93
	46	10.46	3.66	2.86	9.94	3.72	2.67	7.66	4.15	1.85	5.06	4.58	1.10	4.69	4.63	1.01	4.69	4.63	1.01

Abbreviations:

LWT: Leaving water temperature (°C)

DB: Dry-bulb temperature for outdoor air temperature (°C)

CC: Total cooling capacity (kW)

PI: Power input (kW)

R290 M thermal Nature Plus Series



Table 2-6.8: 12kW cooling capacity

LWT	DB	Maximum			100% (Normal)			75%			50%			25%			Minimum		
		CC	EER	PI	CC	EER	PI	CC	EER	PI	CC	EER	PI	CC	EER	PI	CC	EER	PI
5	-5	/	/	/	/	/	/	/	/	/	/	/	/	/	/	/	/	/	/
	0	/	/	/	/	/	/	/	/	/	/	/	/	/	/	/	/	/	/
	5	/	/	/	/	/	/	/	/	/	/	/	/	/	/	/	/	/	/
	10	/	/	/	/	/	/	/	/	/	/	/	/	/	/	/	/	/	/
	15	/	/	/	/	/	/	/	/	/	/	/	/	/	/	/	/	/	/
	19	9.50	4.77	1.99	9.50	4.77	1.99	8.58	4.86	1.77	5.76	5.14	1.12	3.65	5.35	0.68	3.65	5.35	0.68
	20	9.74	4.73	2.06	9.74	4.73	2.06	8.51	4.86	1.75	5.79	5.13	1.13	3.74	5.33	0.70	3.74	5.33	0.70
	25	10.55	3.87	2.73	10.55	3.87	2.73	8.50	4.07	2.09	5.61	4.36	1.29	4.07	4.51	0.90	4.07	4.51	0.90
	30	11.19	3.25	3.45	11.19	3.25	3.45	8.64	3.50	2.47	5.81	3.78	1.54	4.14	3.95	1.05	4.14	3.95	1.05
	35	11.31	2.80	4.04	11.31	2.80	4.04	8.54	3.08	2.77	5.79	3.35	1.73	4.08	3.53	1.16	4.08	3.53	1.16
7	-5	/	/	/	/	/	/	/	/	/	/	/	/	/	/	/	/	/	/
	0	/	/	/	/	/	/	/	/	/	/	/	/	/	/	/	/	/	/
	5	/	/	/	/	/	/	/	/	/	/	/	/	/	/	/	/	/	/
	10	/	/	/	/	/	/	/	/	/	/	/	/	/	/	/	/	/	/
	15	/	/	/	/	/	/	/	/	/	/	/	/	/	/	/	/	/	/
	19	10.13	4.99	2.03	10.13	4.99	2.03	8.50	5.15	1.65	5.87	5.41	1.09	3.96	5.61	0.71	3.96	5.61	0.71
	20	10.38	4.95	2.10	10.38	4.95	2.10	8.43	5.14	1.64	5.92	5.39	1.10	4.05	5.58	0.73	4.05	5.58	0.73
	25	11.24	4.10	2.74	11.24	4.10	2.74	8.49	4.37	1.94	5.78	4.64	1.25	4.33	4.79	0.91	4.33	4.79	0.91
	30	11.92	3.41	3.49	11.45	3.46	3.31	8.55	3.75	2.28	5.61	4.04	1.39	4.44	4.16	1.07	4.44	4.16	1.07
	35	11.80	3.03	3.89	11.50	3.05	3.77	8.59	3.41	2.52	5.66	3.70	1.53	4.37	3.83	1.14	4.37	3.83	1.14
10	-5	/	/	/	/	/	/	/	/	/	/	/	/	/	/	/	/	/	/
	0	/	/	/	/	/	/	/	/	/	/	/	/	/	/	/	/	/	/
	5	/	/	/	/	/	/	/	/	/	/	/	/	/	/	/	/	/	/
	10	/	/	/	/	/	/	/	/	/	/	/	/	/	/	/	/	/	/
	15	10.07	5.59	1.80	10.07	5.59	1.80	8.63	5.73	1.51	5.94	6.00	0.99	4.19	6.17	0.68	4.19	6.17	0.68
	19	11.14	5.39	2.07	11.14	5.39	2.07	8.79	5.62	1.56	5.87	5.92	0.99	4.47	6.06	0.74	4.47	6.06	0.74
	20	11.41	5.33	2.13	11.41	5.37	2.13	8.74	5.61	1.55	5.94	5.92	1.00	4.56	6.05	0.75	4.56	6.05	0.75
	25	12.38	4.50	2.75	11.65	4.58	2.55	8.70	4.87	1.79	5.87	5.50	1.07	4.82	5.81	0.83	4.82	5.81	0.83
	30	13.09	3.69	3.31	11.64	4.04	2.84	8.67	4.33	2.02	5.74	4.67	1.25	4.91	4.78	1.05	4.91	4.78	1.05
	35	13.14	3.20	4.11	11.55	3.36	3.44	8.58	3.65	2.35	5.87	3.92	1.50	4.84	4.03	1.20	4.84	4.03	1.20
11	-5	/	/	/	/	/	/	/	/	/	/	/	/	/	/	/	/	/	/
	0	/	/	/	/	/	/	/	/	/	/	/	/	/	/	/	/	/	/
	5	/	/	/	/	/	/	/	/	/	/	/	/	/	/	/	/	/	/
	10	7.71	5.83	1.32	7.71	5.83	1.32	7.71	5.83	1.32	6.01	6.06	1.00	4.41	6.29	0.71	4.41	6.29	0.71
	15	10.39	5.59	1.86	10.39	5.59	1.86	8.59	5.77	1.49	5.71	6.00	0.94	4.38	6.24	0.70	4.38	6.24	0.70
	19	11.49	5.39	2.13	11.49	5.39	2.13	8.82	5.66	1.56	5.70	5.97	0.95	4.64	6.11	0.76	4.64	6.11	0.76
	20	11.77	5.37	2.21	11.77	5.37	2.21	8.78	5.63	1.56	5.80	5.93	0.98	4.73	6.10	0.78	4.73	6.10	0.78
	25	12.76	4.53	2.82	11.69	4.64	2.52	8.75	4.93	1.77	5.79	5.52	1.11	4.99	5.82	0.86	4.99	5.82	0.86
	30	13.48	3.85	3.50	11.66	4.10	2.89	8.74	4.40	2.02	5.76	4.68	1.25	5.08	4.79	1.08	5.08	4.79	1.08
	35	13.53	3.23	4.19	11.58	3.43	3.38	8.68	3.72	2.34	5.86	4.00	1.47	5.00	4.09	1.22	5.00	4.09	1.22
15	-5	/	/	/	/	/	/	/	/	/	/	/	/	/	/	/	/	/	/
	0	6.37	6.48	0.98	6.37	6.48	0.98	6.37	6.48	0.98	6.00	6.52	0.44	6.00	6.52	0.44	6.00	6.52	0.44
	5	6.18	6.42	0.96	6.18	6.42	0.96	6.18	6.42	0.96	6.00	6.44	0.47	6.00	6.44	0.47	6.00	6.44	0.47
	10	5.89	6.34	0.94	5.89	6.34	0.94	5.89	6.34	0.94	5.89	6.34	0.94	5.44	6.35	0.86	5.44	6.35	0.86
	15	11.74	6.00	1.96	11.74	6.00	1.96	9.03	6.10	1.44	5.94	6.30	0.90	5.23	6.30	0.79	5.23	6.30	0.79
	19	13.03	5.92	2.26	11.79	5.98	2.00	9.02	6.03	1.47	6.04	6.25	0.93	5.44	6.25	0.84	5.44	6.25	0.84
	20	13.34	5.91	2.34	11.68	5.97	1.99	9.05	6.02	1.47	5.99	6.20	0.93	5.52	6.24	0.85	5.52	6.24	0.85
	25	14.36	4.98	2.88	11.89	5.23	2.27	8.89	5.53	1.61	5.93	5.82	1.02	5.76	5.92	0.97	5.76	5.92	0.97
	30	15.08	4.03	3.74	12.00	4.34	2.77	8.96	4.81	1.93	5.99	5.13	1.21	5.80	5.15	1.17	5.80	5.15	1.17
	35	15.16	3.50	4.33	11.96	3.82	3.13	8.80	4.14	2.13	5.88	4.43	1.33	5.69	4.45	1.28	5.69	4.45	1.28

Abbreviations:

LWT: Leaving water temperature (°C)

DB: Dry-bulb temperature for outdoor air temperature (°C)

CC: Total cooling capacity (kW)

PI: Power input (kW)

Table continued on next page ...

Table 2-6.8: 12kW cooling capacity (continued)

LWT	DB	Maximum			100% (Normal)			75%			50%			25%			Minimum		
		CC	EER	PI	CC	EER	PI	CC	EER	PI	CC	EER	PI	CC	EER	PI	CC	EER	PI
18	-5	6.63	7.17	0.96	6.63	7.17	0.96	6.63	7.17	0.96	6.00	7.23	0.86	6.00	7.23	0.86	6.00	7.23	0.86
	0	6.46	7.12	0.94	6.46	7.12	0.94	6.46	7.12	0.94	6.00	7.17	0.87	6.00	7.17	0.87	6.00	7.17	0.87
	5	6.27	7.07	0.92	6.27	7.07	0.92	6.27	7.07	0.92	6.00	7.10	0.87	6.00	7.10	0.87	6.00	7.10	0.87
	10	6.08	7.02	0.87	6.08	7.02	0.87	6.08	7.02	0.87	6.00	7.06	0.85	6.00	7.06	0.85	6.00	7.06	0.85
	15	12.88	6.48	2.03	12.88	6.48	2.03	9.14	6.71	1.36	5.91	7.04	0.84	5.91	7.04	0.84	5.91	7.04	0.84
	19	14.24	6.36	2.31	12.03	6.40	1.88	9.20	6.68	1.38	6.08	6.99	0.87	6.08	6.99	0.87	6.08	6.99	0.87
	20	14.57	6.09	2.39	11.93	6.36	1.88	8.82	6.67	1.32	6.16	6.94	0.89	6.16	6.94	0.89	6.16	6.94	0.89
	25	15.72	5.38	2.95	12.00	6.20	2.10	8.86	6.50	1.47	6.40	6.75	1.02	6.40	6.75	1.02	6.40	6.75	1.02
	30	16.45	4.31	2.91	11.98	5.70	1.96	9.03	6.40	1.41	6.39	6.66	0.96	6.39	6.66	0.96	6.39	6.66	0.96
	35	17.08	3.96	4.31	12.00	4.60	2.61	8.95	4.91	1.82	6.26	5.17	1.21	6.26	5.17	1.21	6.26	5.17	1.21
	40	15.68	3.40	4.61	13.94	3.58	3.90	9.06	4.06	2.23	6.08	4.36	1.39	6.08	4.36	1.39	6.08	4.36	1.39
	43	13.74	3.36	4.07	12.03	3.55	3.39	8.95	3.85	2.32	5.91	4.16	1.42	5.91	4.16	1.42	5.91	4.16	1.42
46	10.89	3.25	3.33	10.89	3.25	3.33	9.04	3.45	2.62	5.92	3.76	1.57	5.72	3.78	1.51	5.72	3.78	1.51	
20	-5	7.13	7.33	0.97	7.13	7.33	0.97	7.13	7.33	0.97	6.40	7.40	0.92	6.40	7.40	0.92	6.40	7.40	0.92
	0	7.00	7.28	0.95	7.00	7.28	0.95	7.00	7.28	0.95	6.40	7.34	0.93	6.40	7.34	0.93	6.40	7.34	0.93
	5	6.80	7.23	0.93	6.80	7.23	0.93	6.80	7.23	0.93	6.40	7.27	0.94	6.40	7.27	0.94	6.40	7.27	0.94
	10	6.64	7.15	0.93	6.64	7.15	0.93	6.64	7.15	0.93	6.40	7.20	0.99	6.40	7.20	0.99	6.40	7.20	0.99
	15	13.62	6.80	2.07	11.84	6.92	1.75	9.24	7.02	1.32	6.50	7.17	0.88	6.50	7.17	0.88	6.50	7.17	0.88
	19	15.09	6.60	2.37	12.10	6.88	1.81	8.98	6.98	1.29	6.54	7.10	0.91	6.54	7.10	0.91	6.54	7.10	0.91
	20	15.46	6.50	2.45	12.01	6.66	1.80	9.02	6.96	1.30	6.61	7.09	0.92	6.61	7.09	0.92	6.61	7.09	0.92
	25	16.55	5.60	2.96	11.85	6.30	1.95	9.05	6.73	1.43	6.83	6.95	1.04	6.83	6.95	1.04	6.83	6.95	1.04
	30	17.31	4.43	3.91	12.01	5.80	2.42	8.98	6.65	1.71	6.82	6.87	1.24	6.82	6.87	1.24	6.82	6.87	1.24
	35	17.41	4.10	4.24	12.09	4.64	2.61	9.00	4.95	1.82	6.67	5.18	1.29	6.67	5.18	1.29	6.67	5.18	1.29
	40	16.55	3.40	4.83	11.94	3.89	3.07	8.94	4.19	2.14	6.48	4.43	1.46	6.48	4.43	1.46	6.48	4.43	1.46
	43	14.21	3.38	4.18	11.95	3.63	3.30	9.09	3.91	2.32	6.29	4.19	1.50	6.29	4.19	1.50	6.29	4.19	1.50
46	11.49	3.27	3.47	11.49	3.27	3.47	9.00	3.56	2.53	6.09	3.85	1.58	6.09	3.85	1.58	6.09	3.85	1.58	
25	-5	8.30	8.26	1.03	8.30	8.26	1.03	8.30	8.26	1.03	8.00	8.29	1.30	8.00	8.29	1.30	8.00	8.29	1.30
	0	8.08	8.21	1.01	8.08	8.21	1.01	8.08	8.21	1.01	7.95	8.22	1.24	7.95	8.22	1.24	7.95	8.22	1.24
	5	7.89	8.16	1.06	7.89	8.16	1.06	7.89	8.16	1.06	7.70	8.18	1.27	7.70	8.18	1.27	7.70	8.18	1.27
	10	7.80	8.12	0.98	7.80	8.12	0.98	7.80	8.12	0.98	7.60	8.14	1.09	7.60	8.14	1.09	7.60	8.14	1.09
	15	15.67	7.57	2.14	11.94	7.71	1.55	8.91	8.01	1.11	7.72	8.13	0.46	7.72	8.13	0.46	7.72	8.13	0.46
	19	16.80	7.51	2.24	11.96	7.67	1.56	8.98	7.97	1.13	7.80	8.09	0.52	7.80	8.09	0.52	7.80	8.09	0.52
	20	17.78	6.99	2.54	11.93	7.58	1.57	9.08	7.86	1.16	7.86	7.98	0.57	7.86	7.98	0.57	7.86	7.98	0.57
	25	18.94	5.68	3.33	12.03	6.37	1.89	9.10	6.95	1.37	7.98	7.06	0.76	7.98	7.06	0.76	7.98	7.06	0.76
	30	19.81	4.82	4.11	12.09	6.00	2.16	8.86	6.85	1.50	7.95	6.94	0.91	7.95	6.94	0.91	7.95	6.94	0.91
	35	19.69	4.34	4.54	12.10	5.09	2.38	8.93	5.41	1.65	7.80	5.52	0.52	7.80	5.52	0.52	7.80	5.52	0.52
	40	18.83	3.57	5.28	12.13	4.24	2.86	8.99	4.55	1.98	7.54	4.69	1.14	7.54	4.69	1.14	7.54	4.69	1.14
	43	16.22	3.45	4.67	11.94	3.90	3.06	9.01	4.20	2.15	7.33	4.36	1.23	7.33	4.36	1.23	7.33	4.36	1.23
46	11.61	3.41	3.38	11.61	3.41	3.38	8.97	3.69	2.43	7.11	3.88	1.83	7.11	3.88	1.83	7.11	3.88	1.83	

Abbreviations:

LWT: Leaving water temperature (°C)

DB: Dry-bulb temperature for outdoor air temperature (°C)

CC: Total cooling capacity (kW)

PI: Power input (kW)

R290 M thermal Nature Plus Series



Table 2-6.9: 14kW cooling capacity

LWT	DB	Maximum			100% (Normal)			75%			50%			25%			Minimum		
		CC	EER	PI	CC	EER	PI	CC	EER	PI	CC	EER	PI	CC	EER	PI	CC	EER	PI
5	-5	/	/	/	/	/	/	/	/	/	/	/	/	/	/	/	/	/	/
	0	/	/	/	/	/	/	/	/	/	/	/	/	/	/	/	/	/	/
	5	/	/	/	/	/	/	/	/	/	/	/	/	/	/	/	/	/	/
	10	/	/	/	/	/	/	/	/	/	/	/	/	/	/	/	/	/	/
	15	/	/	/	/	/	/	/	/	/	/	/	/	/	/	/	/	/	/
	19	10.12	4.70	2.15	10.12	4.70	2.15	9.33	4.78	1.95	6.32	5.08	1.24	3.65	5.35	0.68	3.65	5.35	0.68
	20	10.18	4.69	2.17	10.18	4.69	2.17	9.25	4.77	1.94	6.06	5.07	1.19	3.74	5.33	0.70	3.74	5.33	0.70
	25	11.23	3.80	2.96	11.23	3.80	2.96	9.29	3.99	2.33	6.10	4.31	1.41	4.07	4.51	0.90	4.07	4.51	0.90
	30	12.10	3.16	3.84	12.10	3.16	3.84	9.23	3.44	2.68	6.18	3.75	1.65	4.14	3.95	1.05	4.14	3.95	1.05
	35	12.18	2.72	4.48	12.18	2.72	4.48	9.23	3.01	3.07	6.26	3.31	1.89	4.08	3.53	1.16	4.08	3.53	1.16
	40	11.59	2.44	4.75	11.59	2.44	4.75	9.28	2.67	3.48	6.17	2.98	2.07	3.97	3.20	1.24	3.97	3.20	1.24
43	10.58	2.33	4.55	10.58	2.33	4.55	9.20	2.46	3.73	6.22	2.76	2.25	3.85	3.00	1.28	3.85	3.00	1.28	
46	5.57	2.37	2.35	5.57	2.37	2.35	5.57	2.37	2.35	5.57	2.37	2.35	3.72	2.56	1.45	3.72	2.56	1.45	
7	-5	/	/	/	/	/	/	/	/	/	/	/	/	/	/	/	/	/	
	0	/	/	/	/	/	/	/	/	/	/	/	/	/	/	/	/	/	
	5	/	/	/	/	/	/	/	/	/	/	/	/	/	/	/	/	/	
	10	/	/	/	/	/	/	/	/	/	/	/	/	/	/	/	/	/	
	15	/	/	/	/	/	/	/	/	/	/	/	/	/	/	/	/	/	
	19	10.79	4.89	2.21	10.79	4.89	2.21	9.16	5.09	1.80	6.19	5.38	1.15	3.96	5.61	0.71	3.96	5.61	0.71
	20	10.86	4.88	2.23	10.86	4.88	2.23	9.25	5.06	1.83	6.21	5.36	1.16	4.05	5.58	0.73	4.05	5.58	0.73
	25	11.95	4.00	2.99	11.95	4.00	2.99	9.25	4.29	2.15	6.25	4.59	1.36	4.33	4.79	0.91	4.33	4.79	0.91
	30	12.86	3.29	3.90	12.42	3.36	3.70	9.22	3.68	2.51	6.22	3.98	1.56	4.44	4.16	1.07	4.44	4.16	1.07
	35	13.16	2.93	4.49	12.40	3.00	4.13	9.26	3.34	2.77	6.20	3.65	1.70	4.37	3.83	1.14	4.37	3.83	1.14
	40	12.31	2.76	4.46	12.31	2.76	4.46	9.20	3.09	2.97	6.14	3.40	1.81	4.26	3.59	1.19	4.26	3.59	1.19
43	11.13	2.47	4.50	11.13	2.47	4.50	9.25	2.68	3.45	6.22	2.98	2.09	4.13	3.19	1.29	4.13	3.19	1.29	
46	6.01	2.46	2.45	6.01	2.46	2.45	6.01	2.46	2.45	6.01	2.46	2.45	3.99	2.68	1.49	3.99	2.68	1.49	
10	-5	/	/	/	/	/	/	/	/	/	/	/	/	/	/	/	/	/	
	0	/	/	/	/	/	/	/	/	/	/	/	/	/	/	/	/	/	
	5	/	/	/	/	/	/	/	/	/	/	/	/	/	/	/	/	/	
	10	/	/	/	/	/	/	/	/	/	/	/	/	/	/	/	/	/	
	15	10.46	5.53	1.89	10.46	5.53	1.89	9.53	5.64	1.69	6.35	5.96	1.07	4.19	6.17	0.68	4.19	6.17	0.68
	19	11.87	5.30	2.24	11.87	5.30	2.24	9.62	5.54	1.74	6.56	5.85	1.12	4.47	6.06	0.74	4.47	6.06	0.74
	20	11.94	5.29	2.26	11.94	5.29	2.26	9.54	5.53	1.73	6.27	5.83	1.08	4.56	6.05	0.75	4.56	6.05	0.75
	25	13.10	4.41	2.97	12.92	4.45	2.90	9.52	4.79	1.99	6.40	5.10	1.26	4.82	5.81	0.83	4.82	5.81	0.83
	30	14.06	3.58	3.93	12.72	3.73	3.41	9.61	4.30	2.24	6.42	4.62	1.39	4.91	4.68	1.05	4.91	4.68	1.05
	35	14.11	3.08	4.58	12.85	3.23	3.98	9.69	3.54	2.74	6.46	3.86	1.67	4.84	4.03	1.20	4.84	4.03	1.20
	40	13.49	2.91	4.64	12.77	2.98	4.28	9.65	3.31	2.91	6.44	3.64	1.77	4.71	3.81	1.24	4.71	3.81	1.24
43	12.00	2.70	4.44	12.00	2.70	4.44	9.59	2.96	3.24	6.39	3.28	1.95	4.58	3.46	1.32	4.58	3.46	1.32	
46	8.52	2.61	3.27	8.52	2.61	3.27	8.52	2.61	3.27	6.31	2.85	2.21	4.42	3.04	1.46	4.42	3.04	1.46	
11	-5	/	/	/	/	/	/	/	/	/	/	/	/	/	/	/	/	/	
	0	/	/	/	/	/	/	/	/	/	/	/	/	/	/	/	/	/	
	5	/	/	/	/	/	/	/	/	/	/	/	/	/	/	/	/	/	
	10	8.62	5.72	1.51	8.62	5.72	1.51	8.62	5.72	1.51	6.01	6.06	0.99	4.41	6.29	0.70	4.41	6.29	0.70
	15	10.79	5.53	1.95	10.79	5.53	1.95	9.79	5.65	1.73	6.59	5.97	1.10	4.38	6.24	0.70	4.38	6.24	0.70
	19	12.24	5.38	2.28	12.24	5.38	2.28	9.66	5.58	1.73	6.27	5.92	1.06	4.64	6.11	0.76	4.64	6.11	0.76
	20	12.32	5.33	2.31	12.32	5.33	2.31	9.59	5.55	1.73	6.50	5.86	1.11	4.73	6.10	0.78	4.73	6.10	0.78
	25	13.49	4.44	3.04	12.95	4.51	2.87	9.64	4.84	1.99	6.35	5.17	1.23	4.99	5.82	0.86	4.99	5.82	0.86
	30	14.47	3.71	3.90	12.94	3.91	3.31	9.70	4.31	2.25	6.41	4.66	1.37	5.08	4.80	1.06	5.08	4.80	1.06
	35	14.52	3.11	4.66	12.91	3.29	3.92	9.58	3.63	2.64	6.46	3.94	1.64	5.00	4.09	1.22	5.00	4.09	1.22
	40	13.30	2.94	4.52	13.00	3.00	4.33	9.64	3.33	2.90	6.47	3.64	1.78	4.87	3.82	1.27	4.87	3.82	1.27
43	12.07	2.74	4.40	12.07	2.74	4.40	9.74	2.99	3.25	6.44	3.32	1.94	4.73	3.49	1.35	4.73	3.49	1.35	
46	8.79	2.68	3.28	8.79	2.68	3.28	8.79	2.68	3.28	6.36	2.94	2.16	4.57	3.12	1.47	4.57	3.12	1.47	
15	-5	/	/	/	/	/	/	/	/	/	/	/	/	/	/	/	/	/	
	0	6.53	6.45	1.01	6.53	6.45	1.01	6.53	6.45	1.01	6.53	6.45	1.01	6.00	6.52	0.92	6.00	6.52	0.92
	5	6.34	6.39	0.99	6.34	6.39	0.99	6.34	6.39	0.99	6.34	6.39	0.99	6.00	6.44	0.93	6.00	6.44	0.93
	10	6.05	6.24	0.97	6.05	6.24	0.97	6.05	6.24	0.97	6.05	6.24	0.97	5.44	6.35	0.86	5.44	6.35	0.86
	15	12.19	5.94	2.05	12.19	5.94	2.05	10.14	6.09	1.67	6.94	6.20	1.12	5.23	6.30	0.83	5.23	6.30	0.83
	19	13.88	5.84	2.38	13.46	5.90	2.28	10.04	6.05	1.66	6.63	6.15	1.08	5.44	6.25	0.87	5.44	6.25	0.87
	20	13.97	5.73	2.44	13.55	5.77	2.35	10.32	6.04	1.71	6.72	6.14	1.09	5.52	6.24	0.89	5.52	6.24	0.89
	25	15.15	4.88	3.10	13.55	5.06	2.68	10.20	5.40	1.89	6.66	5.75	1.16	5.76	5.92	0.97	5.76	5.92	0.97
	30	16.21	3.90	4.16	13.76	4.16	3.31	10.12	4.70	2.15	6.76	5.05	1.34	5.80	5.15	1.13	5.80	5.15	1.13
	35	16.28	3.37	4.83	13.61	3.66	3.72	10.20	4.00	2.55	6.66	4.35	1.53	5.69	4.45	1.28	5.69	4.45	1.28
	40	14.95	3.15	4.75	13.42	3.34	4.02	10.13	3.67	2.76	6.71	4.01	1.67	5.53	4.13	1.34	5.53	4.13	1.34
43	13.46	3.13	4.29	13.46	3.13	4.29	10.16	3.48	2.91	6.71	3.83	1.75	5.37	3.96	1.36	5.37	3.96	1.36	
46	9.93	3.09	3.21	9.93	3.09	3.21	9.93	3.09	3.21	6.86	3.42	2.01	5.20	3.59	1.45	5.20	3.59	1.45	

Abbreviations:

LWT: Leaving water temperature (°C)

DB: Dry-bulb temperature for outdoor air temperature (°C)

CC: Total cooling capacity (kW)

PI: Power input (kW)

Table continued on next page ...

Table 2-6.9: 14kW cooling capacity (continued)

LWT	DB	Maximum			100% (Normal)			75%			50%			25%			Minimum		
		CC	EER	PI	CC	EER	PI	CC	EER	PI	CC	EER	PI	CC	EER	PI	CC	EER	PI
18	-5	6.81	7.15	0.95	6.81	7.15	0.95	6.81	7.15	0.95	6.81	7.15	0.95	6.00	7.23	0.83	6.00	7.23	0.83
	0	6.63	7.10	0.93	6.63	7.10	0.93	6.63	7.10	0.93	6.63	7.10	0.93	6.00	7.17	0.84	6.00	7.17	0.84
	5	6.44	7.05	0.91	6.44	7.05	0.91	6.44	7.05	0.91	6.44	7.05	0.91	6.00	7.10	0.85	6.00	7.10	0.85
	10	6.24	7.00	0.89	6.24	7.00	0.89	6.24	7.00	0.89	6.24	7.00	0.89	6.00	7.06	0.85	6.00	7.06	0.85
	15	13.37	6.43	2.08	13.37	6.43	2.08	10.42	6.50	1.60	7.24	6.90	1.05	5.91	7.04	0.84	5.91	7.04	0.84
	19	15.18	6.26	2.42	14.00	6.36	2.20	10.35	6.45	1.60	6.91	6.85	1.01	6.08	6.99	0.87	6.08	6.99	0.87
	20	15.26	6.01	2.54	14.11	6.24	2.26	10.31	6.40	1.61	7.02	6.84	1.03	6.16	6.94	0.89	6.16	6.94	0.89
	25	16.56	5.30	3.12	13.94	5.50	2.53	10.34	6.35	1.63	7.00	6.70	1.05	6.40	6.75	0.95	6.40	6.75	0.95
	30	17.58	4.20	4.18	13.97	4.56	3.06	10.42	6.26	1.66	7.01	6.60	1.06	6.39	6.66	0.96	6.39	6.66	0.96
	35	18.17	3.73	4.87	14.00	4.40	3.18	10.35	4.72	2.19	6.88	5.06	1.36	6.26	5.17	1.21	6.26	5.17	1.21
	40	15.92	3.36	4.74	13.94	3.58	3.90	10.48	3.92	2.67	6.93	4.28	1.62	6.08	4.36	1.39	6.08	4.36	1.39
	43	13.74	3.36	4.09	13.74	3.36	4.09	10.53	3.70	2.85	6.94	4.06	1.71	5.91	4.16	1.42	5.91	4.16	1.42
	46	10.89	3.25	3.35	10.89	3.25	3.35	10.89	3.25	3.35	6.91	3.66	1.89	5.72	3.78	1.51	5.72	3.78	1.51
20	-5	7.31	7.29	1.00	7.31	7.29	1.00	7.31	7.29	1.00	7.31	7.29	1.00	6.40	7.40	0.86	6.40	7.40	0.86
	0	7.12	7.24	0.98	7.12	7.24	0.98	7.12	7.24	0.98	7.12	7.24	0.98	6.40	7.34	0.87	6.40	7.34	0.87
	5	6.92	7.19	0.96	6.92	7.19	0.96	6.92	7.19	0.96	6.92	7.19	0.96	6.40	7.27	0.88	6.40	7.27	0.88
	10	6.81	7.13	0.96	6.81	7.13	0.96	6.81	7.13	0.96	6.81	7.13	0.96	6.40	7.17	0.89	6.40	7.17	0.89
	15	14.15	6.75	2.10	13.87	6.78	2.05	10.63	6.95	1.53	7.06	7.07	1.00	6.50	7.10	0.92	6.50	7.10	0.92
	19	16.08	6.50	2.47	14.08	6.70	2.10	10.19	6.90	1.48	7.05	7.05	1.00	6.54	7.05	0.93	6.54	7.05	0.93
	20	16.15	6.40	2.52	13.95	6.55	2.13	10.60	6.80	1.56	7.15	7.04	1.02	6.61	7.04	0.94	6.61	7.04	0.94
	25	17.44	5.49	3.18	14.02	5.85	2.40	10.37	6.60	1.57	7.00	6.86	1.02	6.83	6.95	0.98	6.83	6.95	0.98
	30	18.55	4.30	4.31	14.09	4.72	2.99	10.43	6.50	1.61	7.03	6.70	1.05	6.82	6.87	0.99	6.82	6.87	0.99
	35	18.58	3.97	4.68	13.99	4.45	3.15	10.47	4.80	2.18	7.10	5.14	1.38	6.67	5.18	1.29	6.67	5.18	1.29
	40	16.55	3.40	4.86	13.93	3.69	3.78	10.50	4.03	2.61	6.92	4.39	1.58	6.48	4.43	1.46	6.48	4.43	1.46
	43	14.21	3.38	4.21	13.83	3.44	4.02	10.53	3.77	2.80	6.95	4.12	1.69	6.29	4.19	1.50	6.29	4.19	1.50
	46	11.49	3.27	3.51	11.49	3.27	3.51	10.38	3.42	3.03	6.94	3.77	1.84	6.09	3.85	1.58	6.09	3.85	1.58
25	-5	8.52	8.24	1.03	8.52	8.24	1.03	8.52	8.24	1.03	8.52	8.24	1.03	8.00	8.29	0.96	8.00	8.29	0.96
	0	8.29	8.19	1.01	8.29	8.19	1.01	8.29	8.19	1.01	7.95	8.22	0.97	7.95	8.22	0.97	7.95	8.22	0.97
	5	8.09	8.14	0.99	8.09	8.14	0.99	8.09	8.14	0.99	7.70	8.18	0.94	7.70	8.18	0.94	7.70	8.18	0.94
	10	7.90	8.10	0.98	7.90	8.10	0.98	7.90	8.10	0.98	7.60	8.14	0.93	7.60	8.14	0.93	7.60	8.14	0.93
	15	16.23	7.52	2.16	13.73	7.68	1.79	10.56	7.80	1.35	7.72	8.13	0.95	7.72	8.13	0.95	7.72	8.13	0.95
	19	17.50	7.40	2.36	14.13	7.60	1.86	10.56	7.75	1.36	7.80	8.09	0.96	7.80	8.09	0.96	7.80	8.09	0.96
	20	18.61	6.89	2.70	14.03	7.37	1.91	10.58	7.74	1.37	7.86	7.98	0.98	7.86	7.98	0.98	7.86	7.98	0.98
	25	19.97	5.56	3.59	13.84	6.19	2.24	10.57	6.80	1.55	7.98	7.06	1.13	7.98	7.06	1.13	7.98	7.06	1.13
	30	21.06	4.60	4.58	14.19	5.34	2.66	10.42	6.70	1.56	7.95	6.94	1.15	7.95	6.94	1.15	7.95	6.94	1.15
	35	21.01	4.18	5.02	13.92	4.91	2.83	10.43	5.26	1.98	7.80	5.52	1.41	7.80	5.52	1.41	7.80	5.52	1.41
	40	18.83	3.55	5.31	14.04	4.05	3.47	10.36	4.41	2.35	7.54	4.69	1.61	7.54	4.69	1.61	7.54	4.69	1.61
	43	16.22	3.45	4.70	13.94	3.70	3.77	10.52	4.04	2.60	7.33	4.36	1.68	7.33	4.36	1.68	7.33	4.36	1.68
	46	11.61	3.41	3.40	11.61	3.41	3.40	10.15	3.57	2.84	7.11	3.88	1.83	7.11	3.88	1.83	7.11	3.88	1.83

Abbreviations:

LWT: Leaving water temperature (°C)

DB: Dry-bulb temperature for outdoor air temperature (°C)

CC: Total cooling capacity (kW)

PI: Power input (kW)

R290 M thermal Nature Plus Series



Table 2-6.10: 16kW cooling capacity

LWT	DB	Maximum			100% (Normal)			75%			50%			25%			Minimum		
		CC	EER	PI	CC	EER	PI	CC	EER	PI	CC	EER	PI	CC	EER	PI	CC	EER	PI
5	-5	/	/	/	/	/	/	/	/	/	/	/	/	/	/	/	/	/	/
	0	/	/	/	/	/	/	/	/	/	/	/	/	/	/	/	/	/	/
	5	/	/	/	/	/	/	/	/	/	/	/	/	/	/	/	/	/	/
	10	/	/	/	/	/	/	/	/	/	/	/	/	/	/	/	/	/	/
	15	/	/	/	/	/	/	/	/	/	/	/	/	/	/	/	/	/	/
	19	10.75	4.60	2.34	10.75	4.60	2.34	10.50	4.65	2.26	7.10	4.99	1.42	3.65	5.35	0.68	3.65	5.35	0.68
	20	11.08	4.58	2.42	11.08	4.58	2.42	10.50	4.64	2.26	7.07	4.98	1.42	3.74	5.33	0.70	3.74	5.33	0.70
	25	12.15	3.69	3.29	12.15	3.69	3.29	10.39	3.86	2.69	7.07	4.19	1.69	4.07	4.51	0.90	4.07	4.51	0.90
	30	13.34	3.01	4.43	13.34	3.01	4.43	10.56	3.29	3.21	7.08	3.64	1.95	4.14	3.95	1.05	4.14	3.95	1.05
	35	13.70	2.54	5.38	13.70	2.54	5.38	10.44	2.87	3.64	7.04	3.21	2.19	4.08	3.53	1.16	4.08	3.53	1.16
	40	12.15	2.36	5.14	12.15	2.36	5.14	10.41	2.54	4.10	7.00	2.88	2.43	3.97	3.20	1.24	3.97	3.20	1.24
43	11.00	2.26	4.86	11.00	2.26	4.86	10.46	2.34	4.47	7.00	2.69	2.61	3.85	3.00	1.28	3.85	3.00	1.28	
46	6.00	2.31	2.60	6.00	2.31	2.60	6.00	2.31	2.60	6.00	2.31	2.60	3.72	2.56	1.45	3.72	2.56	1.45	
7	-5	/	/	/	/	/	/	/	/	/	/	/	/	/	/	/	/	/	
	0	/	/	/	/	/	/	/	/	/	/	/	/	/	/	/	/	/	
	5	/	/	/	/	/	/	/	/	/	/	/	/	/	/	/	/	/	
	10	/	/	/	/	/	/	/	/	/	/	/	/	/	/	/	/	/	
	15	/	/	/	/	/	/	/	/	/	/	/	/	/	/	/	/	/	
	19	11.52	4.80	2.40	11.52	4.80	2.40	10.66	4.90	2.18	7.06	5.26	1.34	3.96	5.61	0.71	3.96	5.61	0.71
	20	11.75	4.78	2.46	11.75	4.78	2.46	10.56	4.89	2.16	7.05	5.23	1.35	4.05	5.58	0.73	4.05	5.58	0.73
	25	12.92	3.89	3.32	12.92	3.89	3.32	10.40	4.14	2.51	6.95	4.48	1.55	4.33	4.79	0.91	4.33	4.79	0.91
	30	14.16	3.14	4.50	14.00	3.16	4.43	10.45	3.52	2.97	7.01	3.86	1.82	4.44	4.16	1.07	4.44	4.16	1.07
	35	14.84	2.68	5.54	14.00	2.70	5.19	10.58	3.13	3.38	7.04	3.48	2.02	4.37	3.83	1.14	4.37	3.83	1.14
	40	12.93	2.66	4.86	12.93	2.66	4.86	10.50	2.92	3.59	7.00	3.27	2.14	4.26	3.59	1.19	4.26	3.59	1.19
43	11.61	2.40	4.83	11.61	2.40	4.83	10.45	2.52	4.15	7.06	2.86	2.47	4.13	3.19	1.29	4.13	3.19	1.29	
46	6.47	2.39	2.71	6.47	2.39	2.71	6.47	2.39	2.71	6.47	2.39	2.71	3.99	2.68	1.49	3.99	2.68	1.49	
10	-5	/	/	/	/	/	/	/	/	/	/	/	/	/	/	/	/	/	
	0	/	/	/	/	/	/	/	/	/	/	/	/	/	/	/	/	/	
	5	/	/	/	/	/	/	/	/	/	/	/	/	/	/	/	/	/	
	10	/	/	/	/	/	/	/	/	/	/	/	/	/	/	/	/	/	
	15	11.23	5.23	2.15	11.23	5.23	2.15	10.84	5.47	1.98	7.49	5.80	1.29	4.19	6.17	0.68	4.19	6.17	0.68
	19	12.64	5.10	2.48	12.64	5.10	2.48	10.75	5.39	2.00	7.20	5.74	1.25	4.47	6.06	0.74	4.47	6.06	0.74
	20	12.89	5.08	2.54	12.89	5.08	2.54	10.85	5.38	2.01	7.21	5.68	1.27	4.56	6.05	0.75	4.56	6.05	0.75
	25	14.13	4.19	3.38	14.13	4.19	3.38	10.71	4.63	2.31	7.21	4.98	1.45	4.82	5.81	0.83	4.82	5.81	0.83
	30	15.45	3.42	4.52	14.22	3.54	4.01	10.81	3.88	2.78	7.10	4.55	1.56	4.91	4.68	1.05	4.91	4.68	1.05
	35	15.80	2.89	5.47	14.43	3.03	4.77	10.80	3.39	3.19	7.22	3.75	1.93	4.84	4.03	1.20	4.84	4.03	1.20
	40	13.80	2.86	4.83	13.80	2.86	4.83	10.70	3.17	3.37	7.11	3.53	2.02	4.71	3.81	1.24	4.71	3.81	1.24
43	12.53	2.58	4.86	12.53	2.58	4.86	10.68	2.81	3.80	7.17	3.16	2.27	4.58	3.46	1.32	4.58	3.46	1.32	
46	9.08	2.53	3.59	9.08	2.53	3.59	9.08	2.53	3.59	7.19	2.72	2.65	4.42	3.04	1.46	4.42	3.04	1.46	
11	-5	/	/	/	/	/	/	/	/	/	/	/	/	/	/	/	/	/	
	0	/	/	/	/	/	/	/	/	/	/	/	/	/	/	/	/	/	
	5	/	/	/	/	/	/	/	/	/	/	/	/	/	/	/	/	/	
	10	8.62	5.70	1.51	8.62	5.70	1.51	8.62	5.70	1.51	7.10	5.85	1.21	4.41	6.29	0.70	4.41	6.29	0.70
	15	11.58	5.33	2.17	11.58	5.33	2.17	10.99	5.49	2.00	7.00	5.81	1.21	4.38	6.24	0.70	4.38	6.24	0.70
	19	13.03	5.20	2.51	13.03	5.20	2.51	10.90	5.41	2.01	7.12	5.75	1.24	4.64	6.11	0.76	4.64	6.11	0.76
	20	13.29	5.18	2.57	13.29	5.18	2.57	10.80	5.39	2.00	7.14	5.70	1.25	4.73	6.10	0.78	4.73	6.10	0.78
	25	14.55	4.29	3.39	14.38	4.33	3.32	10.86	4.68	2.32	7.20	5.05	1.43	4.99	5.82	0.86	4.99	5.82	0.86
	30	15.90	3.43	4.64	14.39	3.72	3.86	10.81	4.08	2.65	7.11	4.65	1.53	5.08	4.80	1.06	5.08	4.80	1.06
	35	16.24	2.90	5.60	14.52	3.09	4.69	10.81	3.46	3.12	7.27	3.82	1.90	5.00	4.09	1.22	5.00	4.09	1.22
	40	13.53	2.87	4.71	13.53	2.87	4.71	10.72	3.18	3.37	7.17	3.53	2.03	4.87	3.82	1.27	4.87	3.82	1.27
43	12.74	2.65	4.80	12.74	2.65	4.80	10.71	2.86	3.75	7.25	3.20	2.26	4.73	3.49	1.35	4.73	3.49	1.35	
46	9.37	2.60	3.60	9.37	2.60	3.60	9.37	2.60	3.60	7.28	2.81	2.59	4.57	3.12	1.47	4.57	3.12	1.47	
15	-5	/	/	/	/	/	/	/	/	/	/	/	/	/	/	/	/	/	
	0	6.70	6.41	1.05	6.70	6.41	1.05	6.70	6.41	1.05	6.70	6.41	1.05	6.00	6.52	0.92	6.00	6.52	0.92
	5	6.50	6.35	1.02	6.50	6.35	1.02	6.50	6.35	1.02	6.50	6.35	1.02	6.00	6.44	0.93	6.00	6.44	0.93
	10	6.20	6.20	1.00	6.20	6.20	1.00	6.20	6.20	1.00	6.20	6.20	1.00	5.44	6.35	0.86	5.44	6.35	0.86
	15	13.07	5.83	2.24	13.07	5.83	2.24	10.62	6.00	1.77	7.38	6.15	1.20	5.23	6.30	0.83	5.23	6.30	0.83
	19	14.74	5.70	2.59	14.74	5.70	2.59	10.99	5.92	1.86	7.45	6.05	1.23	5.44	6.25	0.87	5.44	6.25	0.87
	20	15.02	5.65	2.66	14.81	5.67	2.61	10.90	5.91	1.84	7.50	6.04	1.24	5.52	6.24	0.89	5.52	6.24	0.89
	25	16.37	4.74	3.45	14.76	4.90	3.01	10.93	5.28	2.07	7.59	5.62	1.35	5.76	5.92	0.97	5.76	5.92	0.97
	30	17.77	3.72	4.77	14.71	4.03	3.65	11.21	4.38	2.56	7.30	4.90	1.49	5.80	5.15	1.13	5.80	5.15	1.13
	35	18.30	3.15	5.81	14.82	3.50	4.24	11.23	3.86	2.91	7.35	4.24	1.73	5.69	4.45	1.28	5.69	4.45	1.28
	40	15.26	3.12	4.89	14.77	3.17	4.66	11.01	3.54	3.11	7.52	3.89	1.93	5.53	4.13	1.34	5.53	4.13	1.34
43	13.50	3.11	4.34	13.50	3.11	4.34	10.99	3.36	3.27	7.46	3.71	2.01	5.37	3.96	1.36	5.37	3.96	1.36	
46	10.16	3.05	3.33	10.16	3.05	3.33	10.16	3.05	3.33	7.39	3.33	2.22	5.20	3.59	1.45	5.20	3.59	1.45	

Abbreviations:

LWT: Leaving water temperature (°C)

DB: Dry-bulb temperature for outdoor air temperature (°C)

CC: Total cooling capacity (kW)

PI: Power input (kW)

Table continued on next page ...

Table 2-6.10: 16kW cooling capacity(continued)

LWT	DB	Maximum			100% (Normal)			75%			50%			25%			Minimum		
		CC	EER	PI	CC	EER	PI	CC	EER	PI	CC	EER	PI	CC	EER	PI	CC	EER	PI
18	-5	6.98	6.86	1.02	6.98	6.86	1.02	6.98	6.86	1.02	6.98	6.86	1.02	6.00	7.23	0.83	6.00	7.23	0.83
	0	6.80	6.81	1.00	6.80	6.81	1.00	6.80	6.81	1.00	6.80	6.81	1.00	6.00	7.17	0.84	6.00	7.17	0.84
	5	6.60	6.75	0.98	6.60	6.75	0.98	6.60	6.75	0.98	6.60	6.75	0.98	6.00	7.10	0.85	6.00	7.10	0.85
	10	6.40	6.50	0.98	10.90	6.50	1.68	10.90	6.50	1.68	7.50	6.70	1.12	6.00	7.06	0.85	6.00	7.06	0.85
	15	14.35	6.33	2.27	14.35	6.33	2.27	11.19	6.47	1.73	7.75	6.65	1.16	5.91	7.04	0.84	5.91	7.04	0.84
	19	15.82	6.20	2.55	15.18	6.26	2.42	11.39	6.42	1.77	7.82	6.60	1.19	6.08	6.99	0.87	6.08	6.99	0.87
	20	16.45	6.00	2.74	15.04	6.14	2.45	11.31	6.38	1.77	7.89	6.55	1.20	6.16	6.94	0.89	6.16	6.94	0.89
	25	17.77	5.09	3.49	15.02	5.36	2.80	11.16	5.75	1.94	7.69	6.45	1.19	6.40	6.75	0.95	6.40	6.75	0.95
	30	19.30	3.83	5.04	14.99	4.46	3.36	11.17	4.84	2.31	7.43	6.35	1.17	6.39	6.66	0.96	6.39	6.66	0.96
	35	18.93	3.58	5.29	15.00	4.25	3.53	11.25	4.63	2.43	7.58	4.99	1.52	6.26	5.17	1.21	6.26	5.17	1.21
	40	16.00	3.33	4.80	15.00	3.43	4.37	11.26	3.80	2.96	7.59	4.17	1.82	6.08	4.36	1.39	6.08	4.36	1.39
	43	14.60	3.25	4.49	14.60	3.25	4.49	11.25	3.59	3.14	7.50	3.96	1.89	5.91	4.16	1.42	5.91	4.16	1.42
46	11.15	3.20	3.48	11.15	3.20	3.48	11.15	3.20	3.48	7.53	3.56	2.12	5.72	3.78	1.51	5.72	3.78	1.51	
20	-5	7.50	7.25	1.03	7.50	7.25	1.03	7.50	7.25	1.03	7.50	7.25	1.03	6.40	7.40	0.86	6.40	7.40	0.86
	0	7.30	7.20	1.01	7.30	7.20	1.01	7.30	7.20	1.01	7.30	7.20	1.01	6.40	7.34	0.87	6.40	7.34	0.87
	5	7.10	7.15	0.99	7.10	7.15	0.99	7.10	7.15	0.99	7.10	7.15	0.99	6.40	7.27	0.88	6.40	7.27	0.88
	10	6.90	7.10	0.97	6.90	7.10	0.97	6.90	7.10	0.97	6.90	7.10	0.97	6.40	7.17	0.89	6.40	7.17	0.89
	15	15.16	6.65	2.28	15.16	6.65	2.28	11.05	6.90	1.60	7.55	7.05	1.07	6.50	7.10	0.92	6.50	7.10	0.92
	19	17.01	6.40	2.66	15.09	6.59	2.29	11.37	6.74	1.69	7.91	7.00	1.13	6.54	7.05	0.93	6.54	7.05	0.93
	20	17.39	6.30	2.76	15.20	6.52	2.33	11.31	6.69	1.69	7.53	6.99	1.08	6.61	7.04	0.94	6.61	7.04	0.94
	25	18.76	5.34	3.52	15.02	5.71	2.63	11.28	6.08	1.85	7.63	6.80	1.12	6.83	6.95	0.98	6.83	6.95	0.98
	30	20.24	4.09	4.94	14.97	4.62	3.24	11.27	4.99	2.26	7.47	6.68	1.12	6.82	6.87	0.99	6.82	6.87	0.99
	35	20.00	3.70	5.41	15.06	4.30	3.50	11.44	4.66	2.45	7.56	5.05	1.50	6.67	5.18	1.29	6.67	5.18	1.29
	40	16.60	3.38	4.91	15.06	3.53	4.26	11.33	3.91	2.90	7.59	4.28	1.77	6.48	4.43	1.46	6.48	4.43	1.46
	43	15.10	3.27	4.62	14.91	3.29	4.53	11.37	3.64	3.12	7.61	4.02	1.89	6.29	4.19	1.50	6.29	4.19	1.50
46	12.03	3.25	3.70	12.03	3.25	3.70	11.31	3.29	3.44	7.56	3.66	2.06	6.09	3.85	1.58	6.09	3.85	1.58	
25	-5	8.74	7.97	1.10	8.74	7.97	1.10	8.74	7.97	1.10	8.00	8.29	0.96	8.00	8.29	0.96	8.00	8.29	0.96
	0	8.50	7.92	1.07	8.50	7.92	1.07	8.50	7.92	1.07	7.95	8.22	0.97	7.95	8.22	0.97	7.95	8.22	0.97
	5	8.30	7.87	1.05	8.30	7.87	1.05	8.30	7.87	1.05	7.70	8.18	0.94	7.70	8.18	0.94	7.70	8.18	0.94
	10	8.10	7.80	1.04	8.10	7.80	1.04	8.10	7.80	1.04	7.60	8.14	0.93	7.60	8.14	0.93	7.60	8.14	0.93
	15	17.46	7.40	2.36	15.17	7.57	2.00	11.45	7.72	1.48	7.72	8.13	0.95	7.72	8.13	0.95	7.72	8.13	0.95
	19	18.80	7.30	2.58	15.09	7.55	2.00	11.50	7.68	1.50	7.80	8.09	0.96	7.80	8.09	0.96	7.80	8.09	0.96
	20	19.91	6.80	2.93	14.96	7.30	2.05	11.49	7.58	1.52	7.86	7.98	0.98	7.86	7.98	0.98	7.86	7.98	0.98
	25	21.34	5.40	3.95	15.11	6.02	2.51	11.31	6.40	1.77	7.98	7.06	1.13	7.98	7.06	1.13	7.98	7.06	1.13
	30	22.87	4.47	5.12	15.21	5.24	2.91	11.15	5.64	1.98	7.95	6.94	1.15	7.95	6.94	1.15	7.95	6.94	1.15
	35	22.65	4.00	5.66	15.19	4.75	3.20	11.33	5.13	2.21	7.80	5.52	1.41	7.80	5.52	1.41	7.80	5.52	1.41
	40	19.09	3.50	5.45	15.14	3.90	3.89	11.39	4.27	2.67	7.54	4.69	1.61	7.54	4.69	1.61	7.54	4.69	1.61
	43	17.06	3.35	5.09	14.97	3.56	4.21	11.24	3.93	2.86	7.49	4.35	1.72	7.33	4.36	1.68	7.33	4.36	1.68
46	12.50	3.30	3.79	12.50	3.30	3.79	12.50	3.30	3.79	7.59	3.79	2.00	7.11	3.88	1.83	7.11	3.88	1.83	

Abbreviations:

LWT: Leaving water temperature (°C)

DB: Dry-bulb temperature for outdoor air temperature (°C)

CC: Total cooling capacity (kW)

PI: Power input (kW)

Midea Building Technologies Division
Midea Group

Address: Midea Headquarters Building, 6 Midea Avenue, Shunde, Foshan, Guangdong, China

Postal code: 528311

mbt.midea.com / global.midea.com

Midea reserves the right to change the specifications of the product, and to withdraw or replace products without prior notification or public announcement. Midea is constantly developing and improving its products.

Please note that all pictures in the document are for reference only. Actual products may vary.

