



Midea Building Technologies Division

Service Manual

M thermal Nature Plus Series



CONTENTS

Part 1 General Information.....	3
Part 2 Component Layout and Refrigerant Circuits	6
Part 3 Control and Field Settings.....	14
Part 4 Diagnosis and Troubleshooting.....	58
R290 Service Notice.....	164

Part 1

General Information

1 Product Lineup	4
2 Nomenclature	5

1 Product Lineup

Unit Power Supply	220-240V/1N/50Hz				
Model	MHC-V8WD2N7-B2	MHC-V10WD2N7-B2	MHC-V12WD2N7-B2	MHC-V14WD2N7-B2	MHC-V16WD2N7-B2
Model With backup E-heater 3KW	MHC-V8WD2N7-B2E30	MHC-V10WD2N7-B2E30	MHC-V12WD2N7-B2E30	MHC-V14WD2N7-B2E30	MHC-V16WD2N7-B2E30
Model With backup E-heater 6KW	MHC-V8WD2N7-B2ER60	MHC-V10WD2N7-B2ER60	MHC-V12WD2N7-B2ER60	MHC-V14WD2N7-B2ER60	MHC-V16WD2N7-B2ER60
Model With backup E-heater 9KW	MHC-V8WD2N7-B2ER90	MHC-V10WD2N7-B2ER90	MHC-V12WD2N7-B2ER90	MHC-V14WD2N7-B2ER90	MHC-V16WD2N7-B2ER90
Appearance					

Unit Power Supply	380-415V/3N/50Hz				
Model	MHC-V8WD2RN7-B2	MHC-V10WD2RN7-B2	MHC-V12WD2RN7-B2	MHC-V14WD2RN7-B2	MHC-V16WD2RN7-B2
Model With backup E-heater 3KW	MHC-V8WD2RN7-B2E30	MHC-V10WD2RN7-B2E30	MHC-V12WD2RN7-B2E30	MHC-V14WD2RN7-B2E30	MHC-V16WD2RN7-B2E30
Model With backup E-heater 6KW	MHC-V8WD2RN7-B2ER60	MHC-V10WD2RN7-B2ER60	MHC-V12WD2RN7-B2ER60	MHC-V14WD2RN7-B2ER60	MHC-V16WD2RN7-B2ER60
Model With backup E-heater 9KW	MHC-V8WD2RN7-B2ER90	MHC-V10WD2RN7-B2ER90	MHC-V12WD2RN7-B2ER90	MHC-V14WD2RN7-B2ER90	MHC-V16WD2RN7-B2ER90
Appearance					

Note:

Please note that all photos are for reference only. Actual products may vary.

2 Nomenclature

M	H	C	-	V	16	W	D2	R	N7	-	B2	E	R	90
1	2	3		4	5	6	7	8	9		10	11	12	13

Legend		
No.	Code	Remarks
1	M	Brand: Midea
2	H	Unit type: heat pump
3	C	Structure: Mono
4	V	System type: Inverter
5	16	Capacity Code: 8: 8 kW; 10: 10 kW; 12: 12 kW; 14: 14 kW; 16: 16 kW;
6	W	Cooling type: Air cooling
7	D2	Compressor and fan motor types: All DC
8	R	Heat Pump Power Supply R: 3-phase, 380-415V, 50Hz; Omitted: 1-phase, 220-240V, 50Hz
9	N7	Refrigerant: R290
10	B2	Version code Omitted: First-generation product
11	E	E-heater Omitted: without E-heater
12	R	E-heater Power Supply R: 3-phase, 380-415V, 50Hz; Omitted: 1-phase, 220-240V, 50Hz
13	90	E-heater power 9KW

Part 2

Component Layout and Refrigerant Circuits

1 Layout of Functional Components.....	7
2 Piping Diagrams	11

1 Layout of Functional Components

1.1 8-10kW

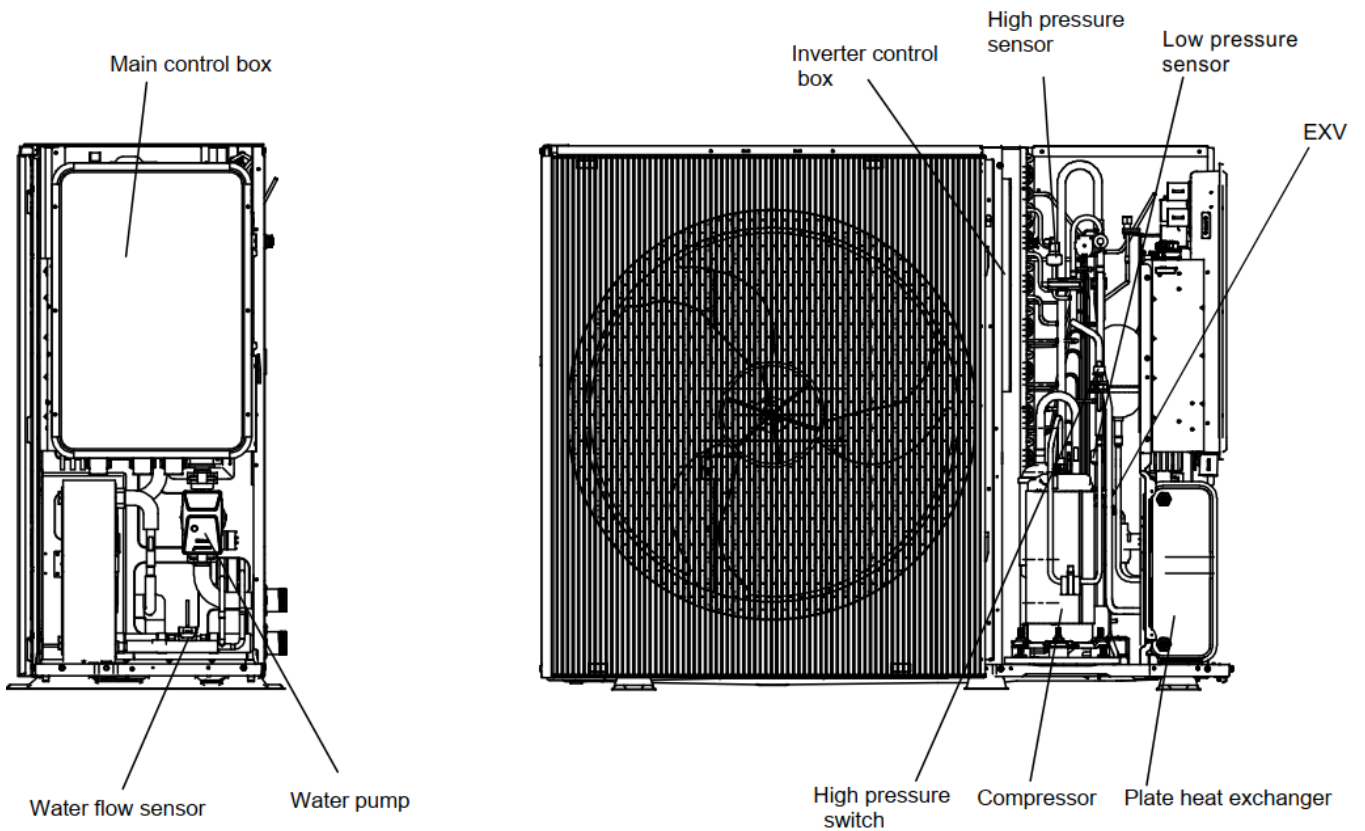
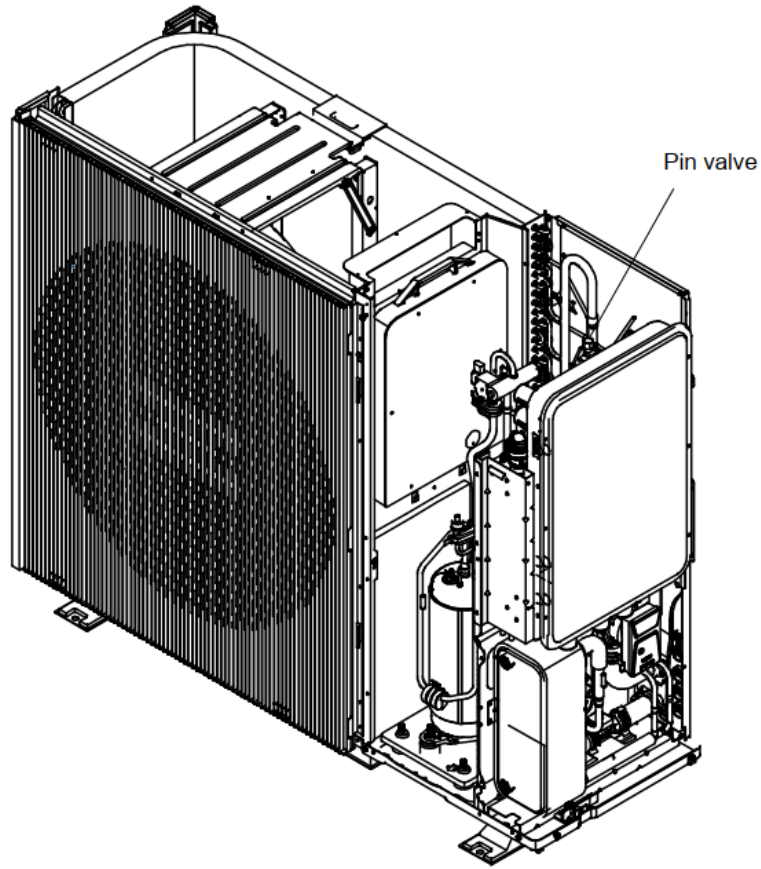

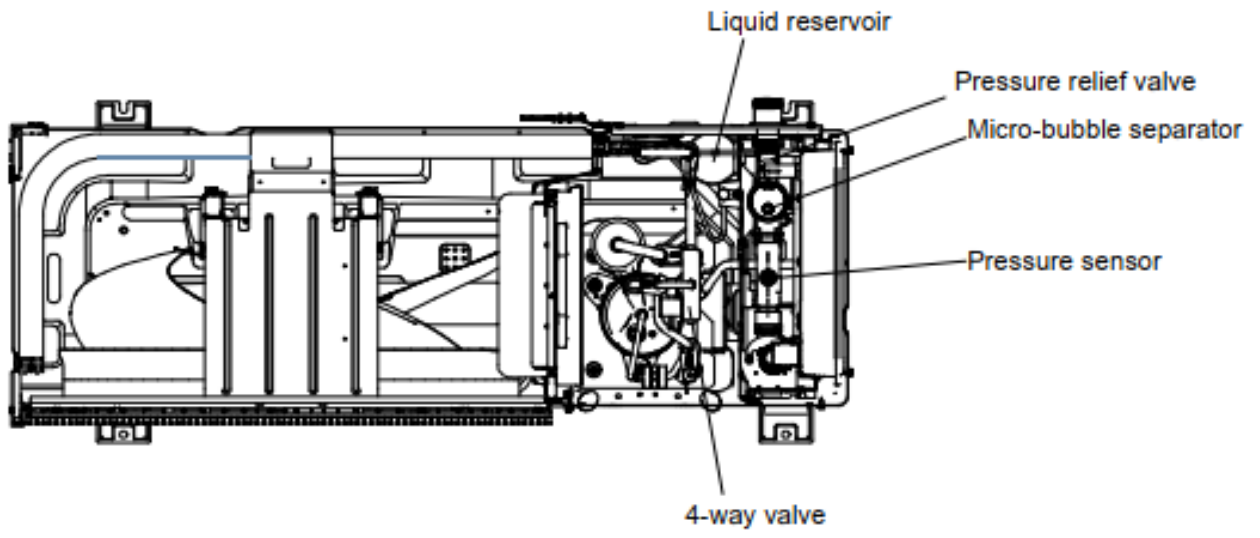
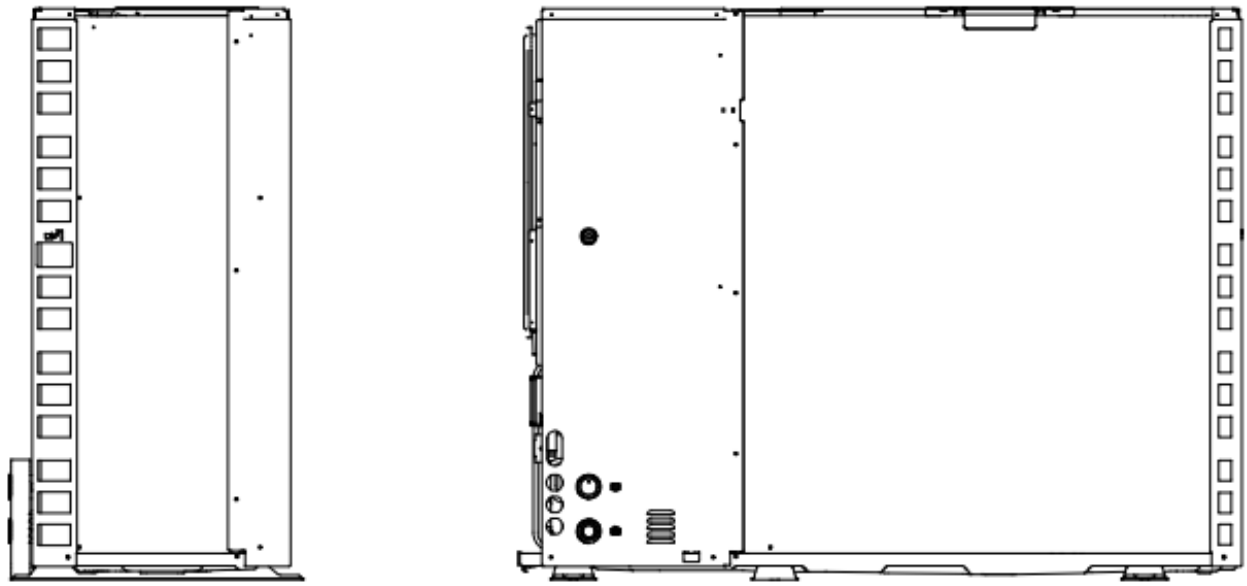

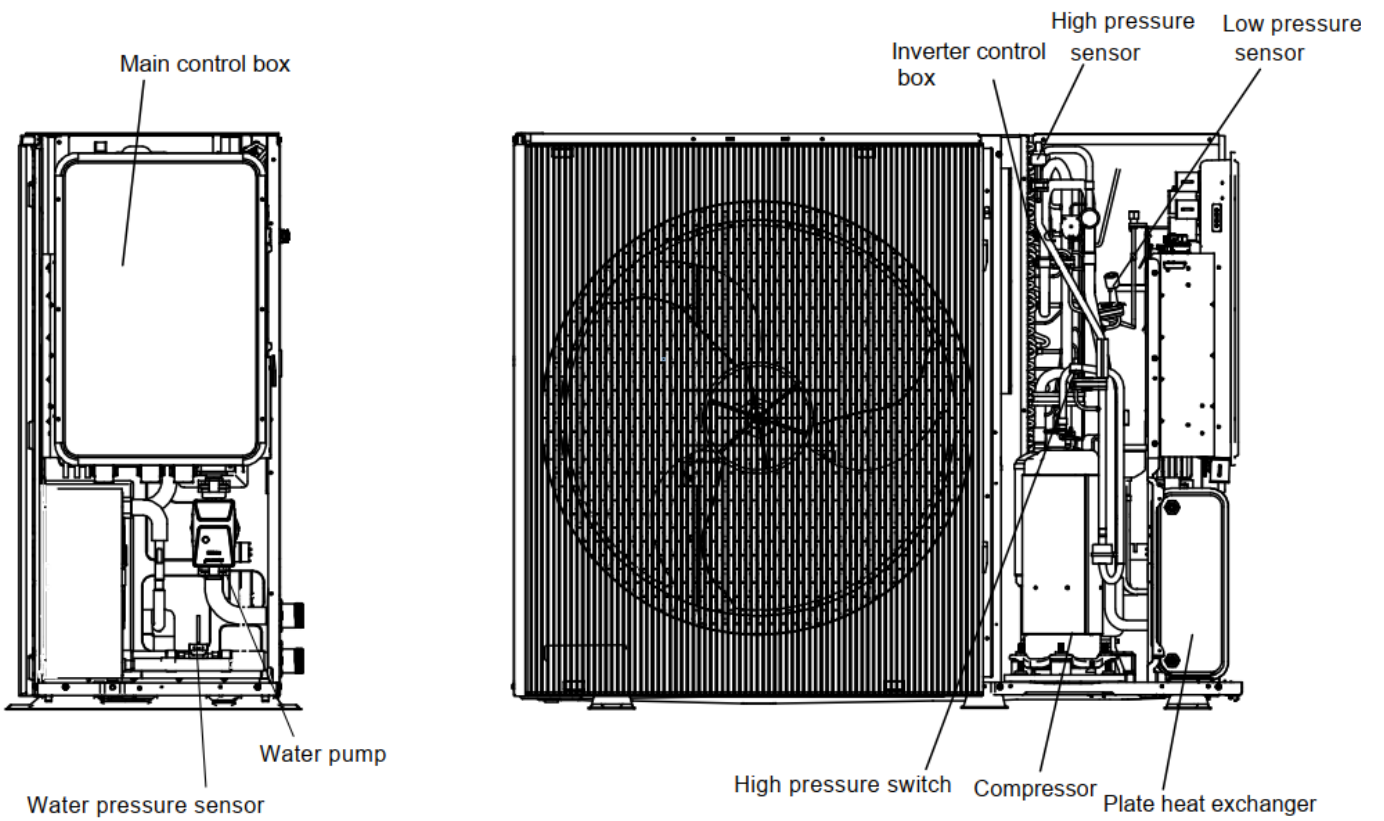
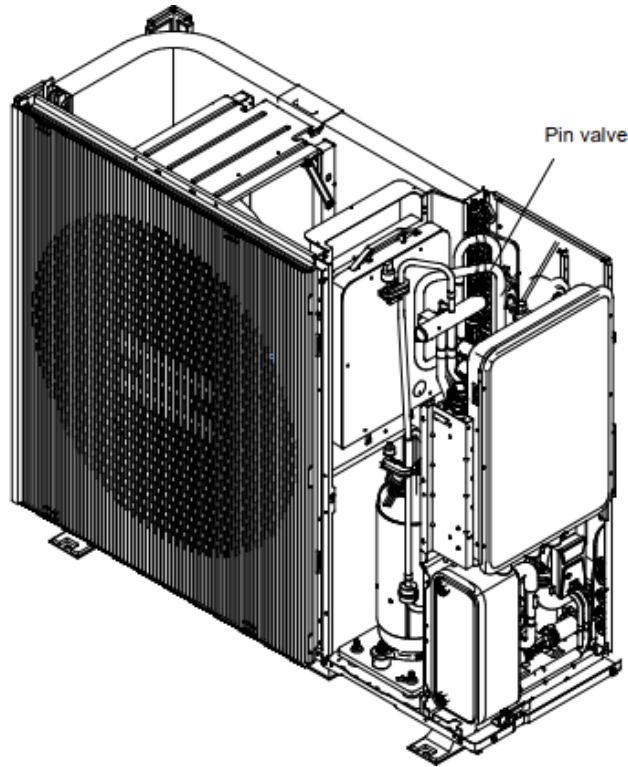

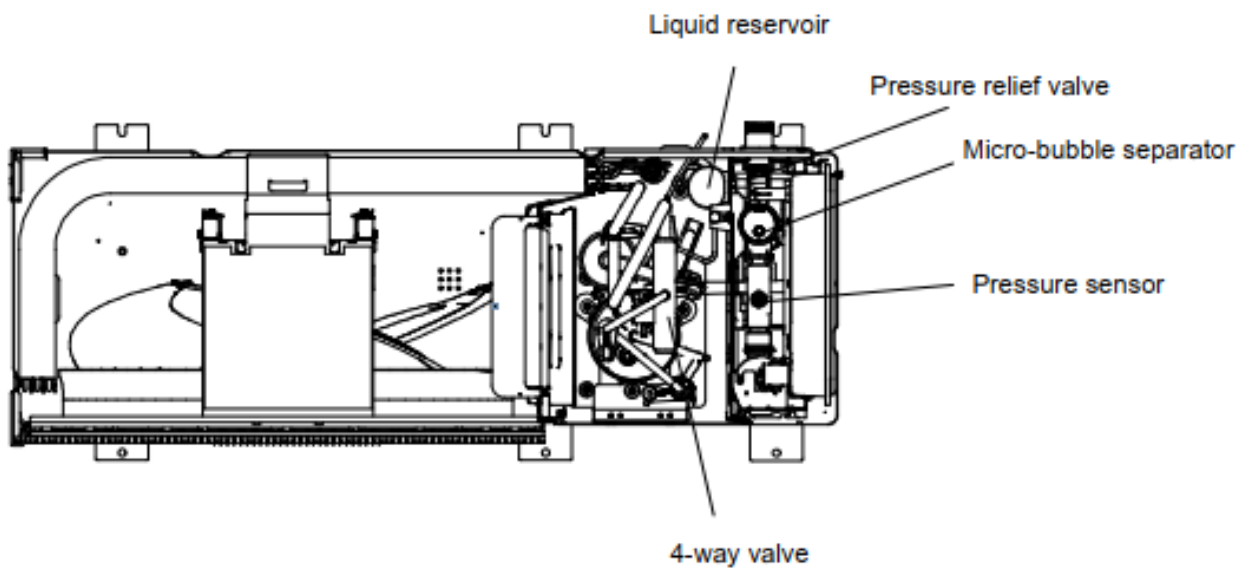
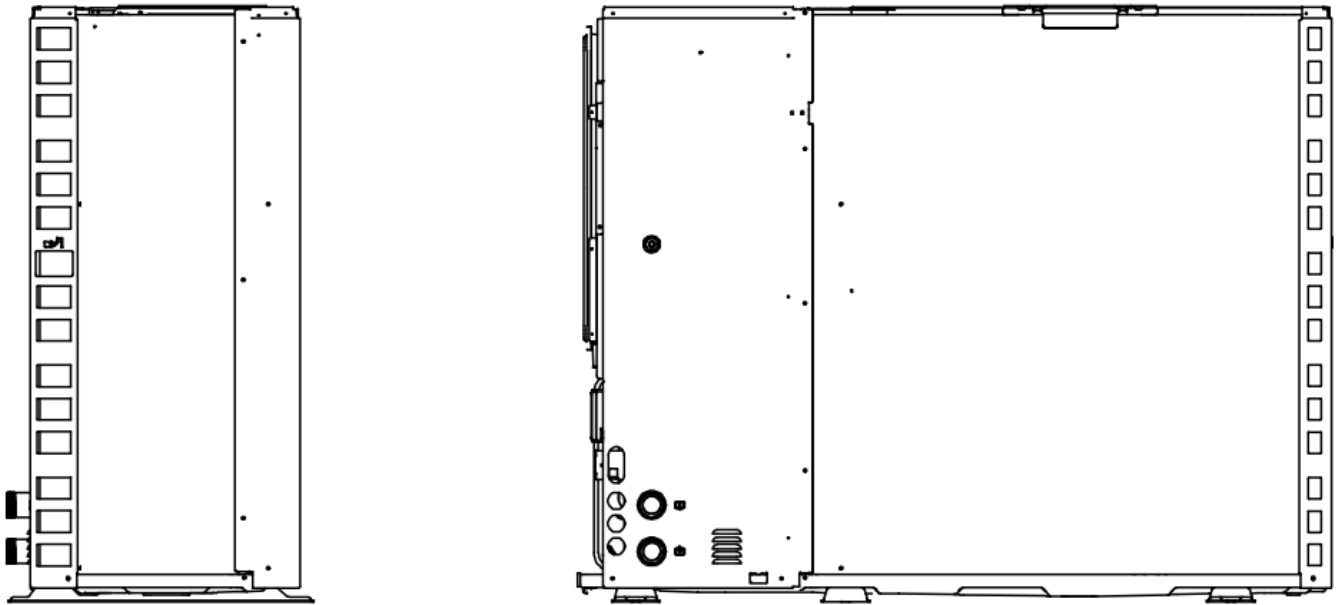

2 Piping Diagrams

Refrigerant piping graphic example:

- High-temperature, high-pressure gas
- Medium-temperature, high-pressure liquid
- Low-temperature, low-pressure gas liquid mixture
- Low-temperature, low-pressure gas

Note: Direction of refrigerant flow depicted in diagram represents main refrigerant flow and is for illustration purposes only.

2.1 Heating mode

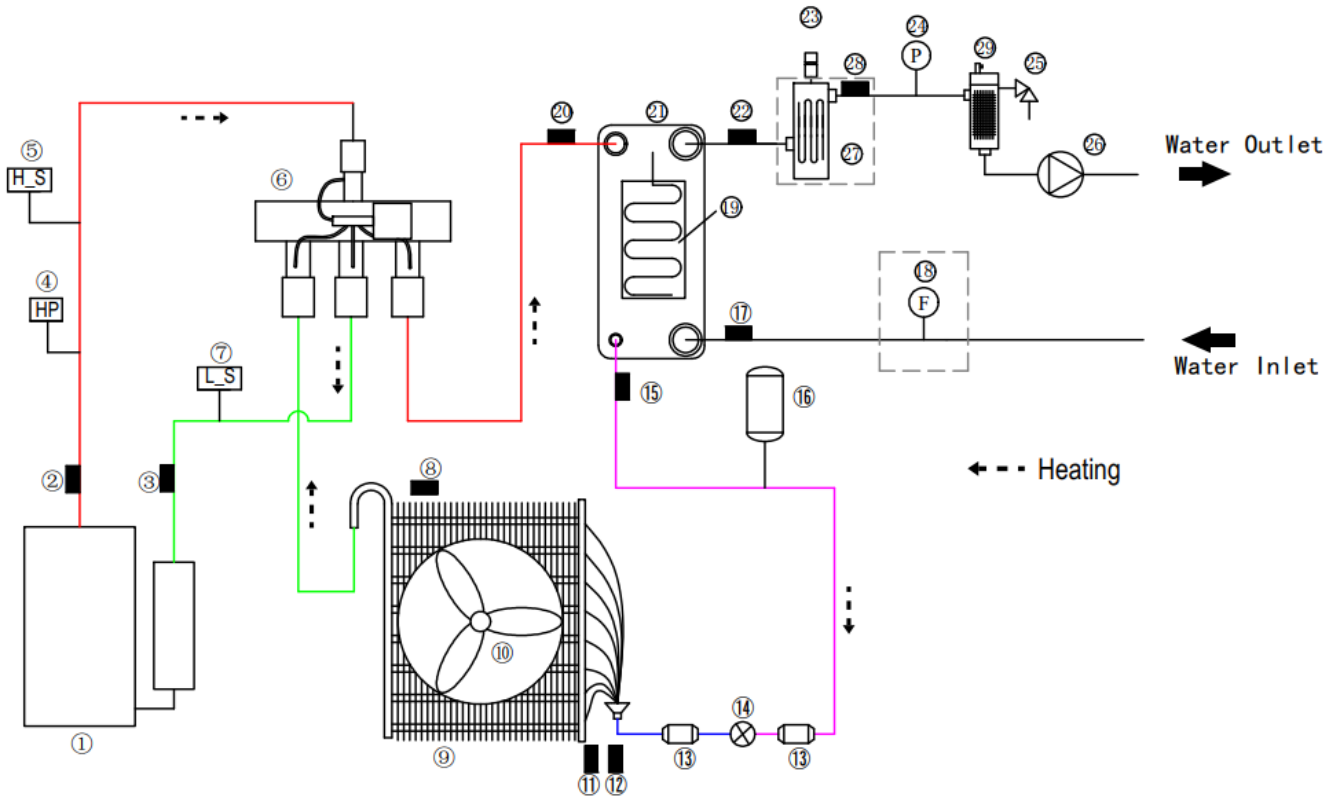

2.2 Cooling mode

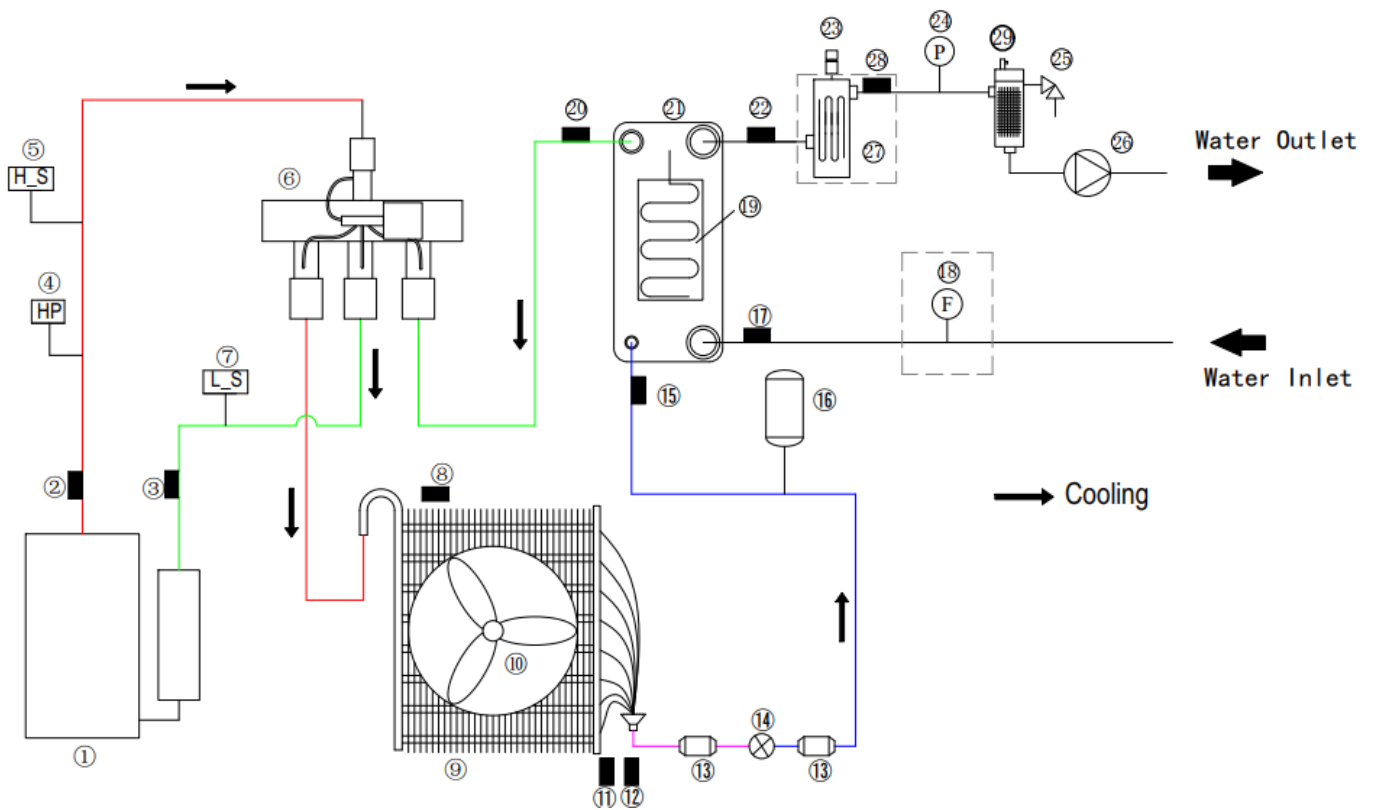

2.3 Key components

1	Compressor
2	Tp Discharge temperature sensor
3	Th Return-air temperature sensor
4	High-pressure switch
5	H-SEN High-pressure sensor
6	4-way valve
7	L-SEN Low-pressure sensor
8	T4 Ambient temperature sensor error
9	Finned tube Heat exchanger
10	Fan
11	T3 Outdoor unit heat exchanger bottom temperature sensor
12	TL Outdoor unit heat exchanger outlet temperature sensor
13	Filter
14	Electronic expansion valve
15	T2 Plate heat exchanger outlet refrigerant temperature sensor
16	Liquid reservoir
17	Tw_in Plate heat exchanger inlet water temperature sensor
18	Water flow sensor
19	Heating tape of Plate heat exchanger
20	T2B Plate heat exchanger inlet refrigerant temperature sensor
21	Plate heat exchanger
22	Tw_out Plate heat exchanger outlet water temperature sensor
23	Automatic air purge valve (for unit with backup heater)

24	Water pressure sensor
25	Pressure relief valve
26	Water pump
27	Backup heater(optional)
28	T1 Backup heater outlet water temperature sensor (equipped with backup heater)
29	Microbubble separator

- **Compressor**

The refrigerant is compressed which also raise its temperature. The refrigerant enters the compressor as a low-pressure, low-temperature gas and exits the compressor as a high-pressure, high-temperature gas.

- **4-way valve**

To better control refrigerant flow, the R290 M thermal Mono series features an upgraded 4-way valve default position which remains closed in heating mode and open in cooling mode. When closed, the air-side heat exchanger functions as an evaporator and water side heat exchanger functions as a condenser; when open, the air side heat exchanger functions as a condenser and water side heat exchanger function as an evaporator.

- **High-pressure switch**

A high-pressure switch regulates system pressure by shutting off the compressor in the event the refrigerant-system pressure exceeds the upper limit.

- **Air side heat exchanger (Finned tube heat exchanger)**

Heat is transferred from the refrigerant into the surrounding air by first passing through the tube coils where the heat is transferred to the fins via conduction. It then dissipates into the air forced through the heat exchanger.

- **Filter**

An air filter traps incoming dust, pet dander, fibers and other airborne contaminants, helping to protect interior heat pump components.

- **Electronic expansion valve (EXV)**

Controls refrigerant flow and reduces refrigerant pressure as necessary.

- **Liquid reservoir**

Stores excess fluid refrigerant during system operation.

- **Plate heat exchanger**

Facilitates transfer of heat between two fluids. This type of exchange offers a significant advantage over conventional heat exchangers as fluids are exposed to a much larger surface area which better facilitates the transfer of heat while greatly accelerating temperature increase.

- **Water pump (Circulating pump)**

Circulates water throughout the water circuit.

- **Pressure relief valve**

Prevents system failure, explosions, or fires by releasing excessive built-up pressure in the system.

- **Internal backup heater (Optional)**

Provides additional heating capacity when the heat pump alone is insufficient due to extremely low outdoor temperatures. It also protects external water piping from freezing.

- **Automatic air purge valve (Optional)**

The unit with internal backup heater has automatic air purge valve. It automatically removes air from the water circuit.

- **Water flow sensor**

Monitors the flow rate of water to detect insufficient flow to the compressor, preventing potential damage.

- **Microbubble separator**

Separates gas from the liquid. The microbubble separator with inner mesh, that can generate rotating flow, promote the separation of air bubbles, increase the adhesion surface of microbubbles, continuously attach & gather & increase and discharge air bubbles.

Part 3

Control and Field settings

1 Shut-off Operation	16
2 Standby Control	16
3 Startup Control	17
4 Normal Operation Control	20
5 System Protection Features.....	22
6 Special Control.....	27
7 User Interface Field Settings.....	28
8 USB Function Field Settings.....	56

Notice

- Refer to system diagram below for location of key components and sensors.
- The diagram below is for reference only. Actual installations will vary based on unique system configurations.

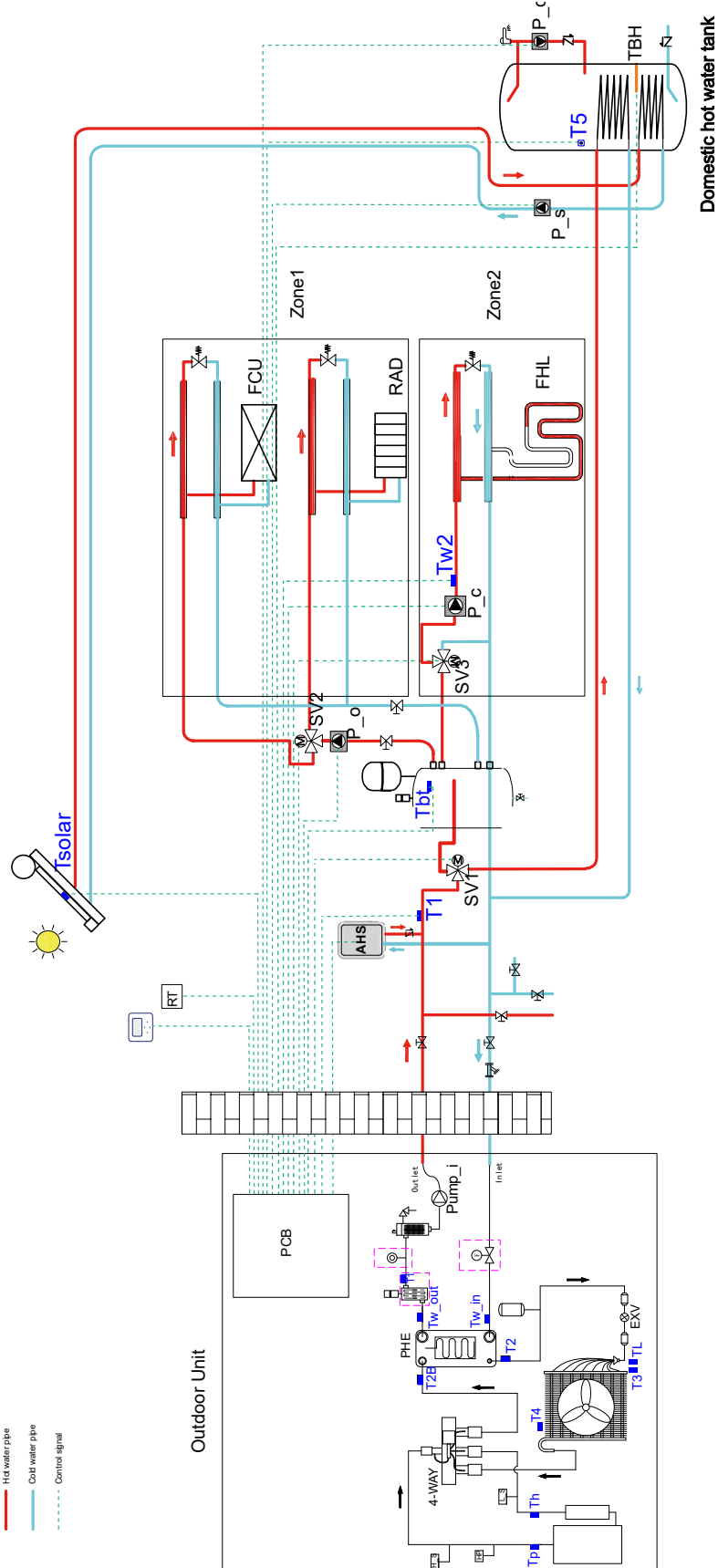

This diagram illustrates the system application only for reference

1 Shut-off Operation

The unit will automatically shut off if one of the following occurs:

- System abnormality: to protect the compressor, a thermal sensor will automatically shut the system off if it detects any abnormality that could potentially cause damage. An error code will show on both the outdoor unit PCB digital display and the user interface.
- Set temperature has been reached: system will shut off

2 Standby Control

2.1 Crankcase Heater Control

A crankcase heater is used to prevent refrigerant from mixing with compressor oil during compressor shutdown. The crankcase heater operation is determined by outdoor ambient temperature and whether the compressor is on or off. When outdoor ambient temperature is above 8°C or the compressor is running, the crankcase heater is off. When outdoor ambient temperature is at or below 5°C and the compressor has either been off for more than 3 hours or the unit has recently been powered on (either manually or following a power outage), the crankcase heater will activate.

2.2 Water Pump Control

- 1) HMI set "Water temperature" control type: If heating or cooling mode =ON, When unit in standby state, the internal and external circulator pumps keep running continuously.
- 2) HMI set "Room temperature" control type: If heating or cooling mode =ON, When unit in standby state, the internal and external circulator pumps will stop running.
- 3) HMI set "Water temperature" control type and "Tbt=YES": If heating or cooling mode =ON, When unit in standby state, the internal circulator pump will stop running and external circulator pumps keep running continuously.

3 Startup Control

3.1 Compressor Startup Delay Control

Startup control and restart control delay compressor startup by three minutes from the last stoppage in order to prevent the potentially harmful effects of frequent compressor on/off cycling and also ensures that pressure within the refrigerant system remains equalized. (Note: this feature will not affect oil return or defrosting operation)

3.2 Programmed Compressor Startup

In initial startup or restart control, compressor startup is determined by outdoor ambient temperature and parameters input into one of two startup programs in order to reach the target rotation speed.

8-10kw compressor startup program when cooling mode ambient temperature is above 12°C and when heating mode ambient temperature is above 0°C

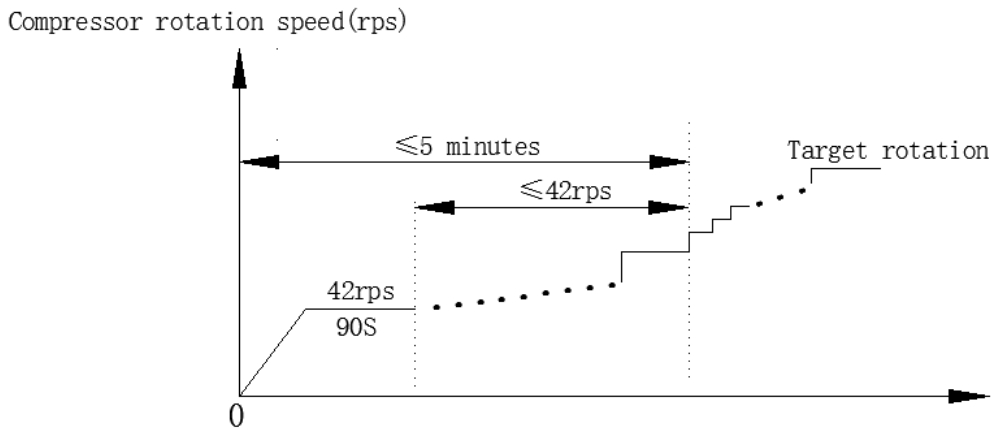

8-10kw compressor startup program when cooling mode ambient temperature is below 12°C and when heating mode ambient temperature is below 0°C

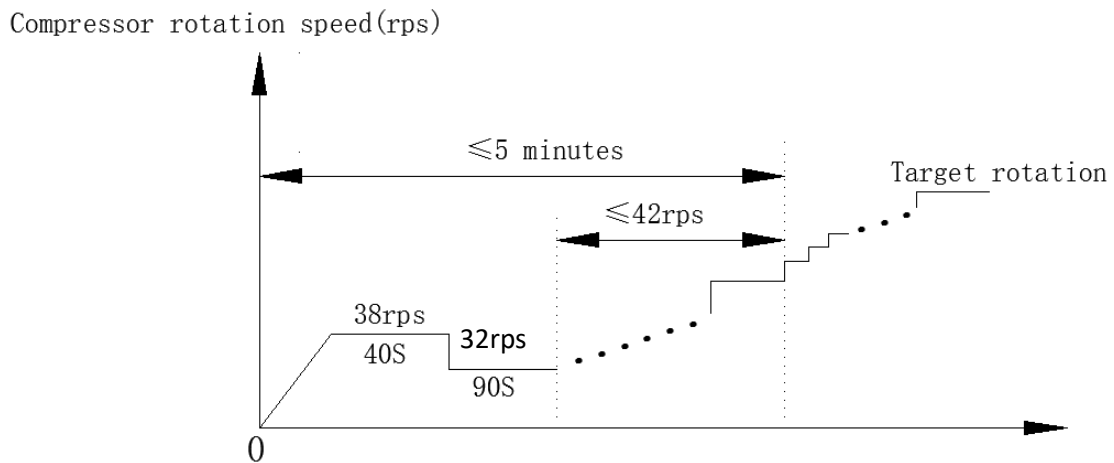

M thermal Nature Plus Series



12-16kw compressor startup program when cooling mode ambient temperature is above 12°C and when heating mode ambient temperature is above 0°C

Compressor rotation speed(rps)

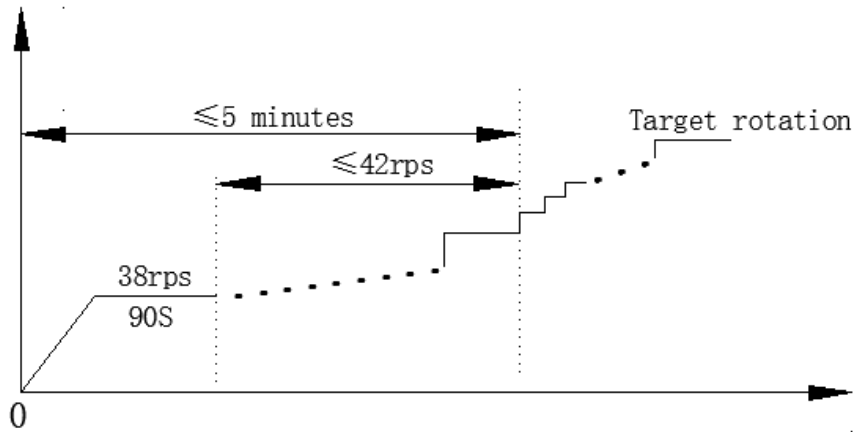

12-16kw compressor startup program when cooling mode ambient temperature is below 12°C and when heating mode ambient temperature is below 0°C

Compressor rotation speed(rps)

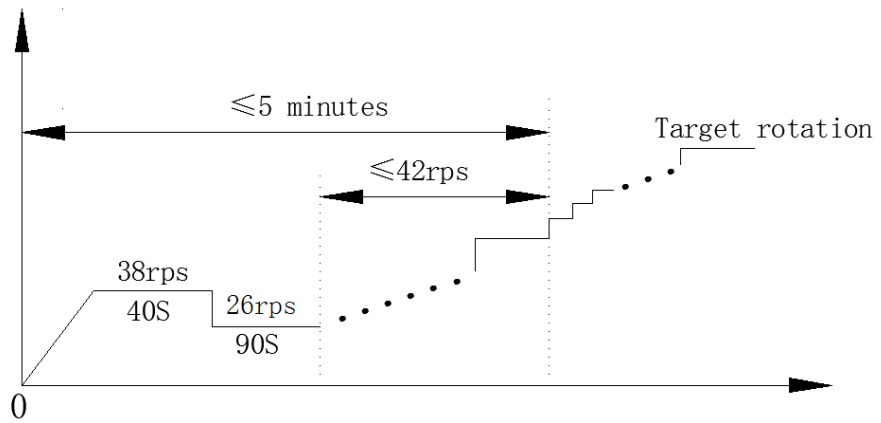

3.3 Startup Control for Heating and Domestic Hot Water (DHW) Operation

Component control during startup in heating and domestic hot water modes

Component	Wiring diagram label	8-16kW	Control functions and status
Inverter compressor	COMP	●	Compressor startup program selected according to ambient temperature ¹
DC fan motor	FAN	●	Fan runs at maximum speed ²
Electronic expansion valve	EXV	●	Increments from 0 (fully closed) to 480 (fully open), controlled according to outdoor ambient temperature, discharge temperature, suction superheat, compressor speed and refrigerant system pressure
Four-way valve	4-WAY	●	OFF
Notes:			
1. Refer to "Startup Control - Compressor Startup Program".			
2. Refer to "Normal Operation Control - Outdoor Fan Control"			

3.4 Startup Control for Cooling Operation

Component control during startup in cooling mode

Component	Wiring diagram label	8-16kW	Control functions and status
Inverter compressor	COMP	●	Compressor startup program selected according to ambient temperature ¹
DC fan motor	FAN	●	Fan run at maximum speed ²
Electronic expansion valve	EXV	●	Increments from 0 (fully closed) to 480 (fully open), controlled according to outdoor ambient temperature, discharge temperature, suction superheat, compressor speed and refrigerant system pressure
Four-way valve	4-WAY	●	ON
Notes:			
1. Refer to "Startup Control - Compressor Startup Program".			
2. Refer to "Normal Operation Control - Outdoor Fan Control"			

4 Normal Operation Control

4.1 Component Control during Normal Operation

Component control during heating and domestic hot water (DHW) operations

Component	Wiring diagram label	8-16kW	Control functions and status
Inverter compressor	COMP	•	Controlled according to load requirement determined by temperature and outdoor water temperature settings.
DC fan motor	FAN	•	Controlled according to outdoor heat exchanger pipe temperature
Electronic expansion valve	EXV	•	Increments from 0 (fully closed) to 480 (fully open), controlled according to outdoor ambient temperature, discharge temperature, suction superheat, compressor speed , refrigerant system pressure and temperature
Four-way valve	4-WAY	•	OFF

Component control during cooling operation

Component	Wiring diagram label	8-16kW	Control functions and status
Inverter compressor	COMP	•	Controlled according to load requirement determined by temperature and outdoor water temperature settings.
DC fan motor	FAN	•	Controlled according to outdoor heat exchanger pipe temperature
Electronic expansion valve	EXV	•	Increments from 0 (fully closed) to 480 (fully open), controlled according to outdoor ambient temperature, discharge temperature, suction superheat, compressor speed and refrigerant system pressure
Four-way valve	4-WAY	•	ON

4.2 Compressor Output Control

The compressor rotation speed is influenced by the load requirement. Before compressor startup, the outdoor unit calculates the target speed based on the outdoor ambient temperature, set leaving water temperature, and actual leaving water temperature. It then runs the appropriate compressor startup program. (Refer to Part 3.2 “Compressor Startup Program”). After completion of the startup program, the compressor operates at the specified rotation speed. During operation, compressor speed is modulated based rate of water temperature change, refrigerant system pressure and the refrigerant temperature.

4.3 Compressor Frequency Control

The running speed of a six-pole compressor, measured in rotations per second (rps), is one third of the electrical input frequency in hertz (Hz) to the motor. The frequency of the electrical input to the compressor can be altered at a rate of 1Hz per second.

4.4 Four-way Valve Control

A four-way valve is employed to change the direction of the refrigerant flow through the water-side heat exchanger which enables switching between cooling and heating/DHW operations. The valve is open during cooling but closed during heating and DHW production.

4.5 Electronic Expansion Valve Control

The electronic expansion valve (EXV) is controlled in increments from 0 (fully closed) to 480 (fully open).

- At power-on:
 - The EXV first closes fully, then moves to the standby at the 480 increments position. After the compressor activates, the EXV control is determined by suction superheat discharge temperature, pressure, discharge temperature and compressor speed.
- When the outdoor unit is in standby mode:
 - The EXV is at the 480 increment.
- When the outdoor unit shut offs:
 - The EXV first moves to the 480 increment where it remains for 30 seconds. It then closes fully before moving to the standby position at the 480 increment.

4.6 Outdoor Fan Control

The outdoor unit fan speed can be adjusted in a series of incremental steps as shown below.

Fan speed control during operation					
Fan speed index	Fan speed (rpm)				
	8kW	10kW	12kW	14kW	16kW
W1	150	150	150	150	150
W2	180	180	180	180	180
W3	200	200	200	200	200
W4	230	230	230	230	230
W5	250	250	250	250	250
W6	300	300	300	300	300
W7	320	320	320	320	320
W8	350	350	350	350	350
W9	380	380	380	380	380
W10	400	400	400	400	400
W11	420	420	430	430	430
W12	450	450	450	450	450
W13	450	450	480	480	480

5 System Protection Features

5.1 High Pressure Protection

This feature protects the refrigerant system from abnormally high pressure and also protects the compressor from transient spikes in pressure.

High pressure protection control

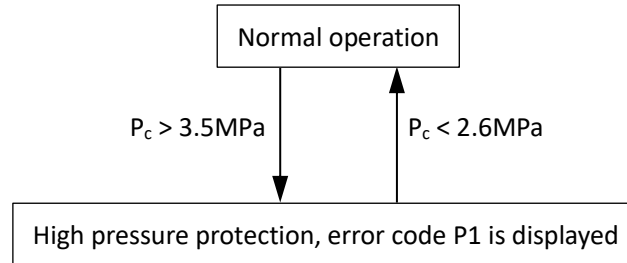

Notes:

1. P_c : Discharge pressure

When the discharge pressure rises above 3.5MPa the system displays the error code P1 and the unit shuts down. When the discharge pressure drops below 2.6MPa, the compressor restarts.

5.2 Low Pressure Protection

This feature protects the refrigerant system from abnormally low pressure and also protects the compressor from transient drops in pressure.

Low pressure protection control

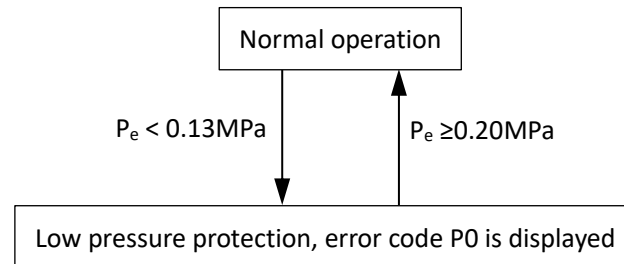

Notes:

1. P_e : Suction pressure

When the suction pressure drops below 0.13MPa the system displays the error code P0 and the unit shuts down. When the suction pressure rises above 0.2MPa, the compressor enters re-start control.

5.3 Discharge Temperature Protection Control

This control protects the compressor from abnormally high temperatures and transient spikes in temperature.

High discharge temperature protection control

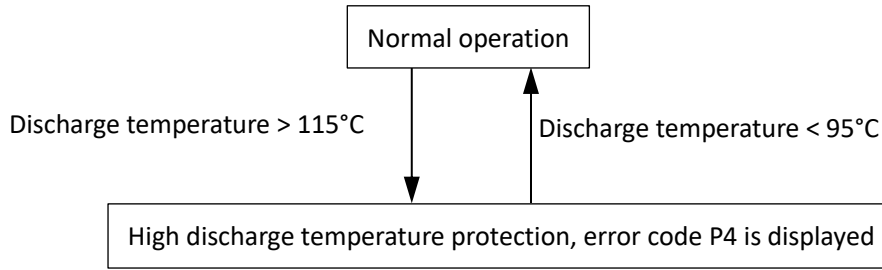

When the discharge temperature rises above 115°C the system displays the error code P4 and the unit shuts down. When the discharge temperature drops below 95°C, the compressor enters re-start control.

Low discharge temperature protection control

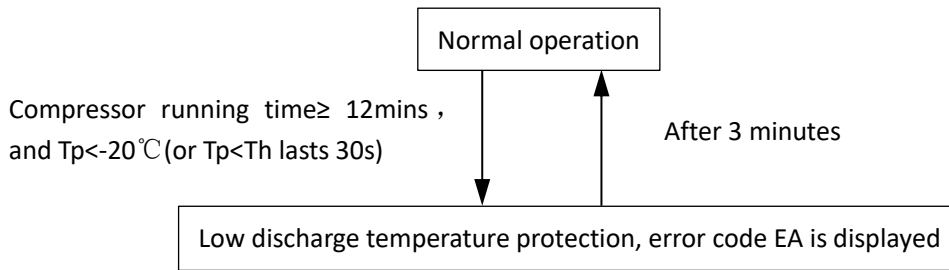

When the discharge temperature (T_p) is below suction temperature (T_h) for more than 12 minutes after compressor operates, the system displays the error code EA and the unit shuts down. After 3 minutes the compressor enters re-start control.

Note: EA protection occurs 3 times within 2 hours, the outdoor unit cannot be restarted unless it is powered on again.

5.4 Compressor Current Protection Control

This control protects the compressor from abnormally high currents.

Figure 3-5.5: Compressor current protection control

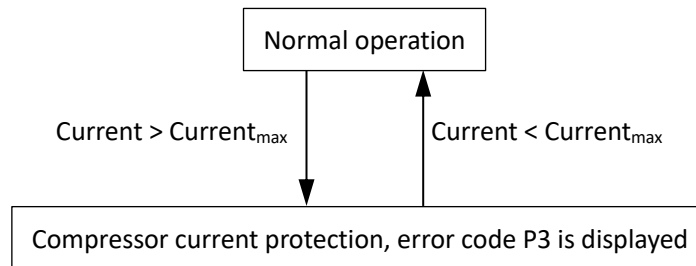

Current limitation for ODU

Model		1-ph 8kw	1-ph 10kw	3-ph 8-10kW	1-ph 12-16kw	3-ph 12-16kw
Current _{max}	Cool mode	17	17	7	29	10
	Heat or DHW mode	19.5	21	8	31	11

When the compressor current rises above $Current_{max}$ the system displays the error code P3 and the unit shuts down. When the compressor current drops below $Current_{max}$, the compressor enters re-start control.

5.5 Voltage Protection Control

This control protects the M-Thermal Split from abnormally high or abnormally low voltages.

Figure 3-5.6: Compressor voltage protection control

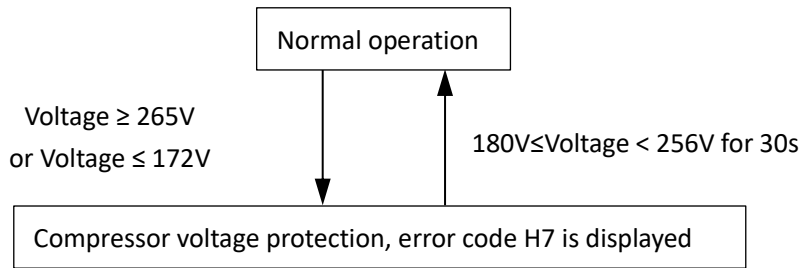

When the phase voltage of AC power supply is at or above 265V, the system displays the error code H7 and the unit shuts down. When the phase voltage drops below 265V for more than 30 seconds, the refrigerant system restarts once the compressor re-start delay has elapsed. When the phase voltage is below 172V, the system displays the error code H7 and the unit shuts down. When the AC voltage rises to more than 180V, the refrigerant system restarts once the compressor re-start delay has elapsed.

5.6 DC Fan Motor Protection Control

This control protects the DC fan motors from strong winds and abnormal power supply. DC fan motor protection occurs when any one of the following conditions are met:

- Fan speed continues to be less than 50rpm more than 40S from the set fan step >0
- Fan speed is lower than 50rpm for 3S, during normal operation

When DC fan motor protection control occurs the system displays the H6 error code and the unit shuts down. After 30S, the unit restarts automatically. When H6 protection occurs 10 times in 120 minutes, the HH error is displayed. When an HH error occurs, a manual system restart is required before the system can resume operation.

5.7 Anti-freezing Protection Control

This control protects the water-side heat exchanger from ice formation. The water-side heat exchanger electric heater is controlled according to outdoor ambient temperature, water-side heat exchanger water inlet temperature and water-side heat exchanger water outlet temperature.

In cooling mode, if inlet water temperature or leaving water temperature or auxiliary heat source leaving water temperature is below 4°C, the anti-freeze protection actions. In heating/DHW mode, if ambient temperature is below 3°C and inlet water temperature or leaving water temperature or auxiliary heat source leaving water temperature is below 4°C, the anti-freeze protection actions. In heating/DHW mode, leaving water temperature is below 2°C, the anti-freeze protection actions.

When water-side heat exchanger anti-freeze protection occurs the system displays error code Pb and the unit shuts down. .

Note: For the clear and concise understanding of anti-freeze protection control, the diagram is illustrated as below.

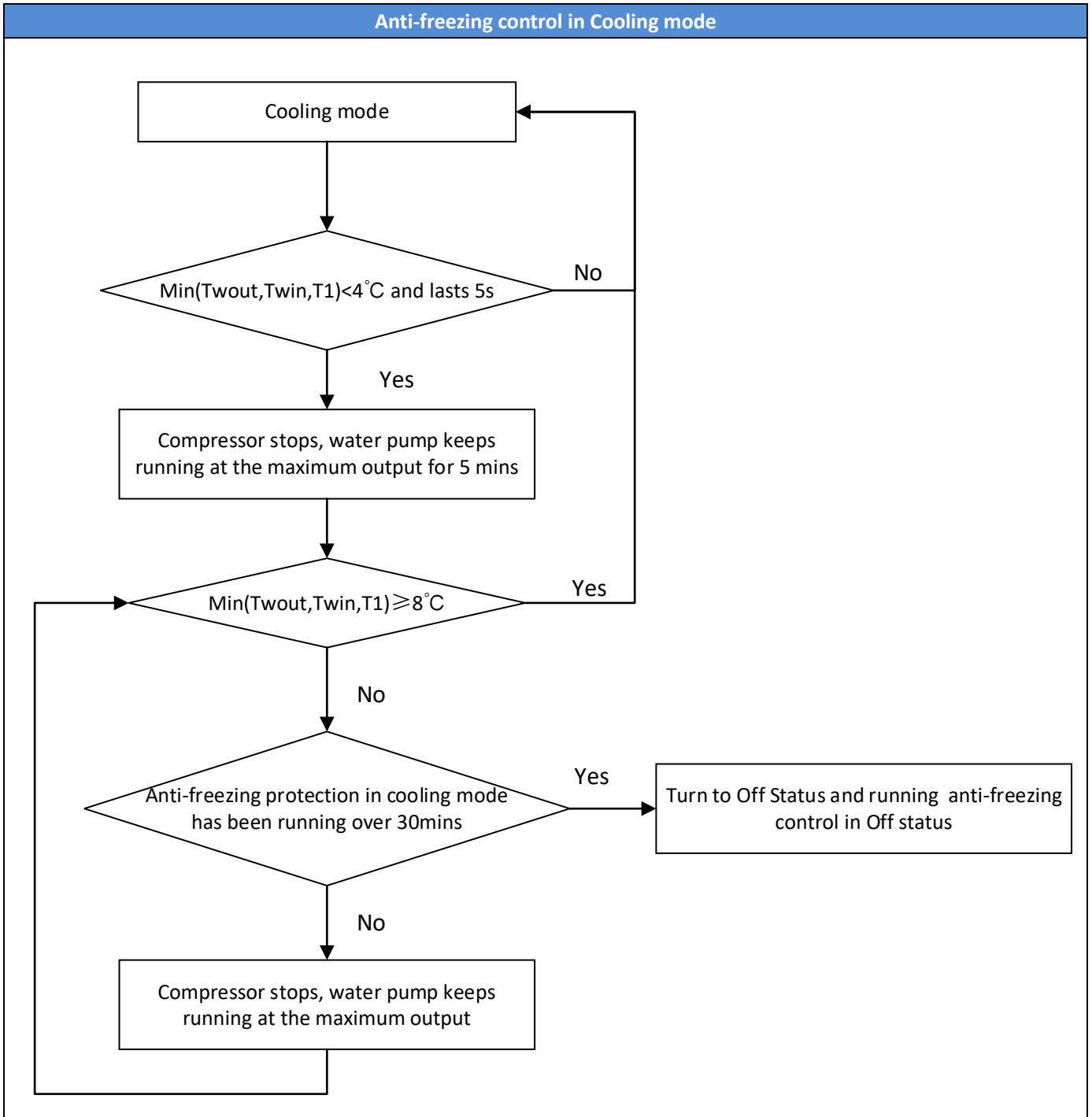

Tw_out: Plate heat exchanger outlet water temperature

Tw_in: Plate heat exchanger inlet water temperature

T1: Electric Heater/AHS water outlet temperature

Anti-freezing control in Off status/ Heating mode/ DHW mode

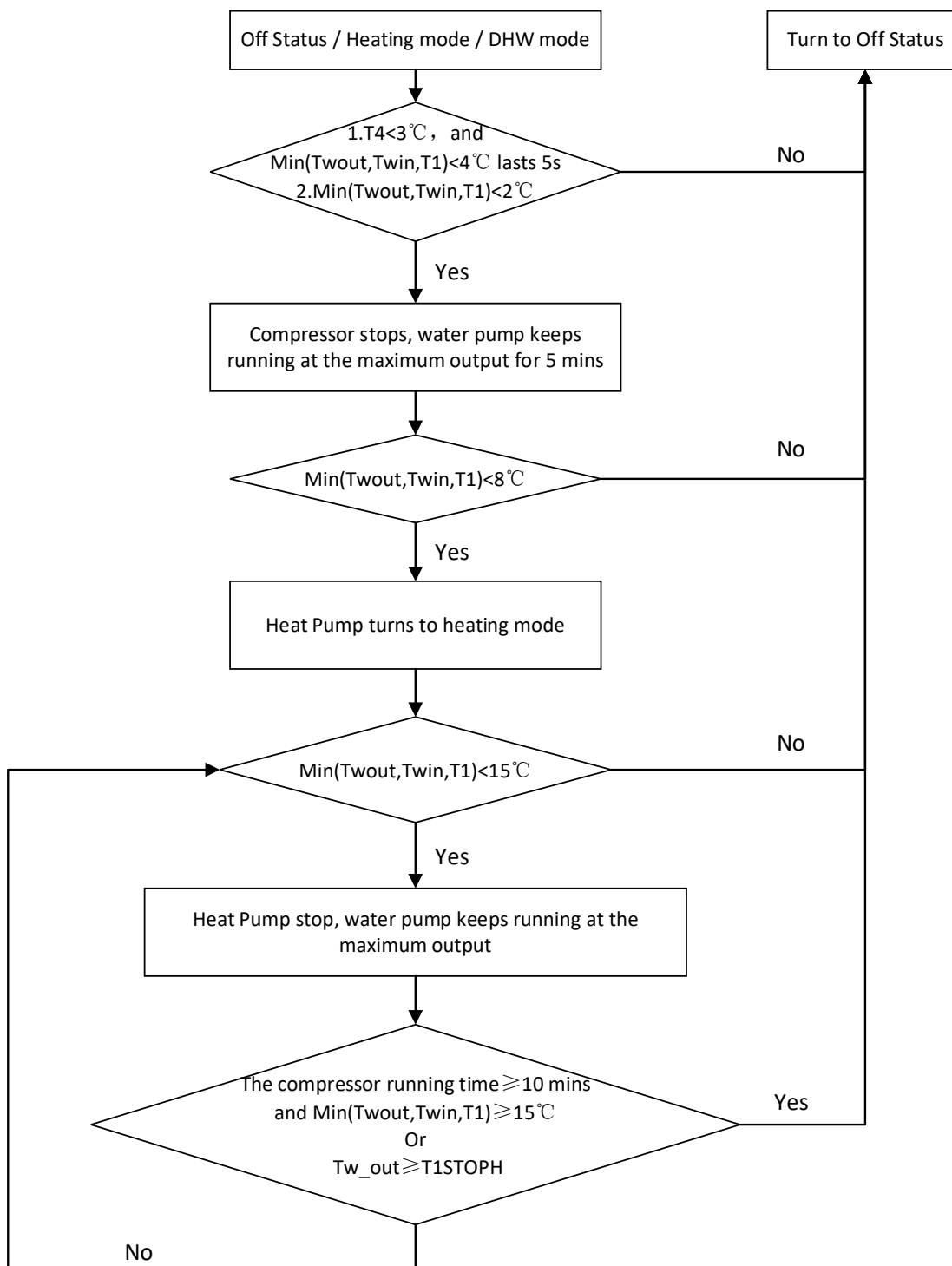

T4: Ambient temperature

Tw_out: Plate heat exchanger outlet water temperature

Tw_in: Plate heat exchanger inlet water temperature

T1: Electric Heater/AHS water outlet temperature

T1STOPH: The maximum temperature to stop compressor in heating mode

6 Special Control

6.1 Oil Return Operation

In order to prevent the compressor from running out of oil, the oil return operation is conducted to recover oil that has flowed out of the compressor and into the refrigerant piping. When the oil return operation is being conducted, the outdoor unit refrigerant system main PCB displays code d0.

The oil return operation starts when the following condition occurs:

- When the compressor cumulative operating time with running rotation speed less than 42rps reaches 6 hours.

The oil return operation ceases when any one of the following two conditions occurs:

- Oil return operation duration reaches 5 minutes.
- Compressor stops.

Component control during oil return operation in **cooling mode**.

Component	Wiring diagram label	8-16kW	Control functions and status
Inverter compressor	COMP	●	Runs at oil return operation rotation speed
DC fan motor	FAN	●	Controlled according to cooling mode
Electronic expansion valve	EXV	●	304 (steps)
Four-way valve	4-WAY	●	ON

Component control during oil return operation in **heating and DHW** modes.

Component	Wiring diagram label	8-16kW	Control functions and status
Inverter compressor	COMP	●	Runs at oil return operation rotation speed
DC fan motor	FAN	●	Controlled according to heating mode
Electronic expansion valve	EXV	●	304 (steps)
Four-way valve	4-WAY	●	OFF

6.2 Defrosting Operation

In order to recover heating capacity, the defrosting operation is conducted when the outdoor unit air-side heat exchanger is performing as a condenser. The defrosting operation is controlled according to outdoor ambient temperature, air-side heat exchanger refrigerant outlet temperature and the compressor running time.

Component control during defrosting operation

Component	Wiring diagram label	8-16kW	Control functions and status
Inverter compressor	COMP	●	Runs at defrosting operation rotation speed
DC fan motor	FAN	●	Off
Electronic expansion valve	EXV	●	Fully open
Four-way valve	4-WAY	●	ON

7 User Interface Field Settings

7.1 Introduction

During installation, the parameters setting should be configured by the installer to suit the installation configuration, climate conditions and end-user preferences. The relevant settings are accessible and programmable through the FOR **SERVICEMAN** menu on the user interface. The user interface menus and settings can be navigated using the touch-sensitive keys.

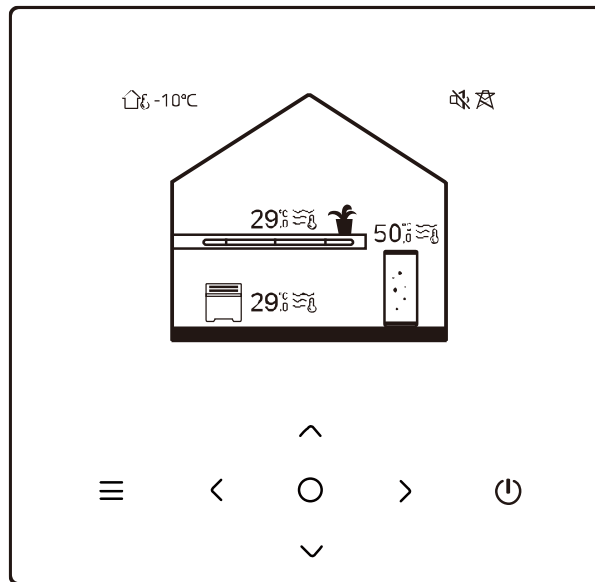

Icon	Name	Function
☰	Menu	Press to access the menu page (from the home page) Return to the previous page(from a page other than the home page)
	Return	Hold for 2 seconds to return to the main page.(except in home page, in For serviceman mode, in USB function mode, in dry connector control mode)
○	Confirm	Confirm a selection Save settings Access the next page
⏻	ON/OFF	Turn on/off zone 1/zone 2/DHW individually Press and hold for 3 seconds to turn on/off zone 1 / zone 2 / DHW all at once
< ^ > v	Navigation	Press to navigate the cursor to adjust settings (holding it for 1 second can start quick adjustment)

Combinations of buttons:

Press ☰ and > simultaneously for 3 seconds to enter the **For serviceman** menu.

7.2 Menu Structure

For serviceman

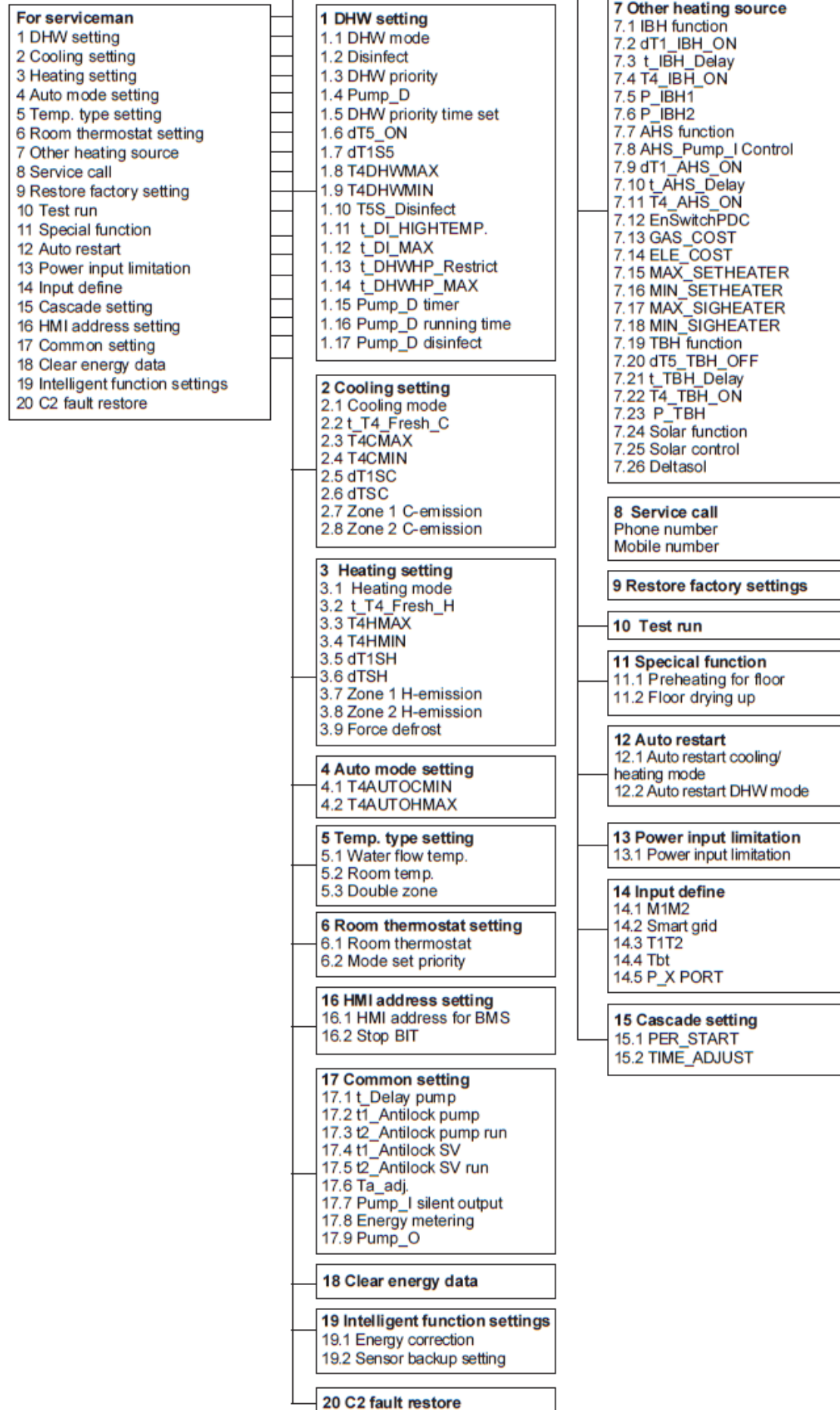

There are some items that are invisible if the function is disabled or unavailable.

7.3 FOR SERVICEMAN Menu

For serviceman allows installers to input the system configuration and set the system parameters.

Press \equiv and $\>$ simultaneously for 3 seconds to enter the authorization page.

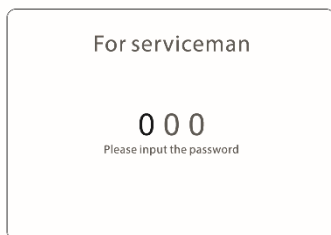

Press \leftarrow \rightarrow to navigate cursor and press \diamond to adjust the numerical values. The password is 234. Press \circ to enter For serviceman menu.

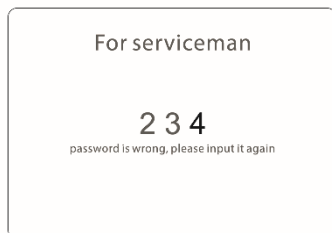

Then the following pages will be displayed:

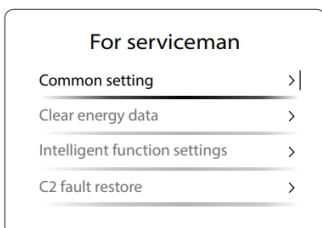
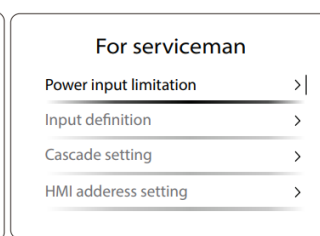
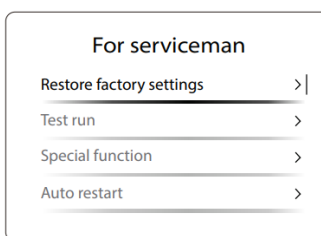
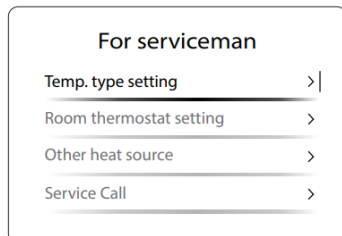
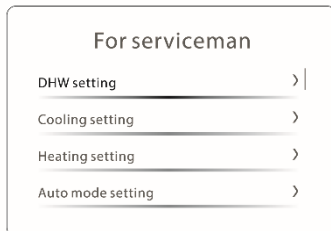

7.3.1 DHW heating setting

DHW setting		DHW setting		DHW setting		DHW setting	
DHW mode	YES	DHW priority time set	NO	T4DHWMIN	-10°C	t_DHWHP_RESTRICT	30minutes
Disinfect	YES	dT5_ON	10°C	T5S_DISINFECT	65°C	t_DHWHP_MAX	90minutes
DHW priority	YES	dT1S5	10°C	t_DI_HIGHTEMP	15minutes	PUMP_D_TIMER	YES
Pump_D	YES	T4DHWMAX	45°C	t_DI_MAX	210minutes	PUMP_D_RUNNING TIME	5minutes

DHW setting	
PUMP_D_DISINFECT	YES

7.3.1.1 DHW mode

DHW mode defines whether hot water demand is needed.

Setting	Description
YES	Enable DHW mode if DHW tank is installed.
NO	Disable DHW mode if DHW tank is not installed. In this case, no need to define other settings in DHW setting , all other settings in DHW setting will be invisible.

7.3.1.2 Disinfect, T5S_DISINFECT, t_DI_HIGHTEMP, t_DI_MAX

Disinfect defines whether disinfection function is activated.

Setting	Description
YES	Enable DHW tank disinfection function.
NO	Disable DHW tank disinfection function.

T5S_DISINFECT defines the target water temperature of water tank for disinfection function.

t_DI_HIGHTEMP defines Period that disinfection water target temperature maintains.

t_DI_MAX defines maximum duration of disinfection mode.

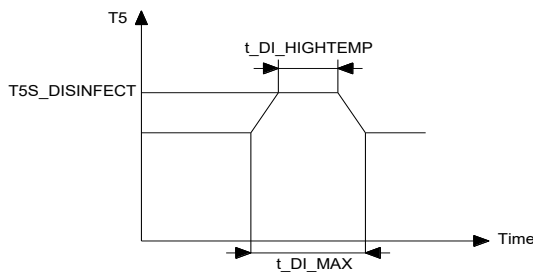

Abbreviations:

T5: DHW tank water temperature

M thermal Nature Plus Series

7.3.1.3 DHW priority, DHW priority time set, t_DHWHP_RESTRICT, t_DHWHP_MAX

DHW priority defines whether domestic hot water or space heating/cooling takes priority.

Setting	Description
YES	When DHW demand and space heating/cooling demand both exist, heat pump will heat the water according to the setting of DHW priority time set, t_DHWHP_RESTRICT, t_DHWHP_MAX
NO	When DHW demand and space heating/cooling demand both exist, heat pump will heat the water after space heating/cooling demand is satisfied.

DHW priority time set defines whether **t_DHWHP_RESTRICT**(the operation time of heating/cooling mode) is to be considered before switching to DHW mode and whether **t_DHWHP_MAX**(the operation time of DHW mode) is to be considered before switching to heating/cooling mode.

Setting	Description
YES	Enable the setting of t_DHWHP_RESTRICT, t_DHWHP_MAX
NO	Disable the setting of t_DHWHP_RESTRICT, t_DHWHP_MAX

t_DHWHP_RESTRICT defines the period that heat pump runs in space heating/cooling mode before switching to DHW mode if DHW requirement exists.

t_DHWHP_MAX defines the period that heat pump runs in DHW mode before switching to space heating/cooling mode if space heating/cooling requirement exists.

Diagram below illustrates the effects of **t_DHWHP_MAX** and **t_DHWHP_RESTRICT** when **DHW PRIORITY** and **DHW priority time set** are enabled.

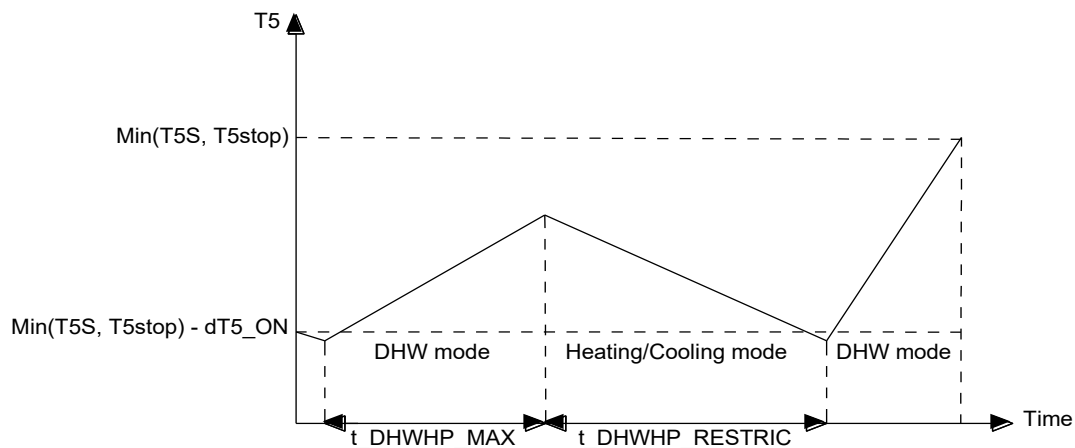

Abbreviations:

T5: DHW tank water temperature

T5S: DHW tank set temperature

T5stop: Leaving water temperature operating limit of DHW mode

DHW PRIORITY	DHW PRIORITY TIME SET	t_DHWHP_RESTRICT	t_DHWHP_MAX	Heating/Cooling turns to DHW	DHW turns to Heating/Cooling
YES	YES	A min	B min	andand DHW mode ON andand $T5 < \text{MIN}(T5S, T5STOP) - dT5_ON$ andand Heating/Cooling mode operates for A mins	DHW mode OFF $T5 \geq \text{MIN}(T5S, T5STOP)$ DHW mode operates for B mins andand Heating/Cooling mode ON
YES	NO	-	-	andand DHW mode ON andand $T5 < \text{MIN}(T5S, T5STOP) - dT5_ON$	DHW mode OFF $T5 \geq \text{MIN}(T5S, T5STOP)$ andand Heating/Cooling mode ON
NO	-	-	-	andand DHW mode ON andand $T5 < \text{MIN}(T5S, T5STOP) - 1$ andand Heating/Cooling mode OFF	Heating/Cooling mode ON

Diagram below illustrates the effects when **DHW priority time set** is disabled.

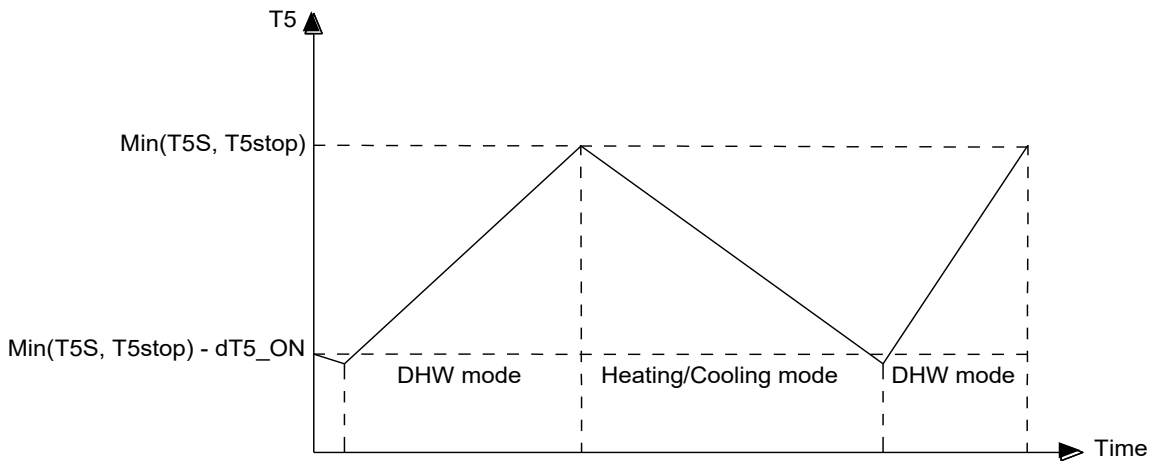

Abbreviations:

T5: DHW tank water temperature

T5S: DHW tank set temperature

T5stop: Leaving water temperature operating limit of DHW mode

7.3.1.4 Pump_D, PUMP_D TIMER, PUMP_D RUNNING TIME, PUMP_D DISINFECT

DHW pump(**Pump_D**) is installed to circulate the water in the DHW pipe network.

Setting	Description
YES	Installation with DHW pump.
NO	Installation without DHW pump.

M thermal Nature Plus Series



PUMP_D TIMER defines whether DHW pump operation schedule which is defined in the user menu is activated.

Setting	Description
YES	Enable DHW pump run in timer.
NO	Disable DHW pump run in timer.

PUMP_D RUNNING TIME defines the period that DHW pump operates for each timer

Diagram below illustrates the effects of **PUMP_D RUNNING TIME** when **Pump_D** is installed and **PUMP_D TIMER** is enable.

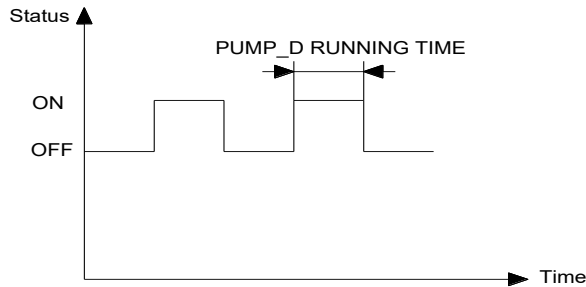

PUMP_D DISINFECT defines whether DHW pump operation is activated in disinfection mode.

Setting	Description
YES	When heat pump is in disinfection mode and $T5S_DISINFECT - T5 \leq 2$, DHW pump operates PUMP_D RUNNING TIME+5 minutes T5S_DISINFECT: DHW tank disinfection set temperature T5: DHW tank temperature
NO	Disable the DHW pump operates when heat pump is in disinfection mode

7.3.1.5 dT5_ON

dT5_ON defines water temperature hysteresis of activating heat pump.

When $T5S - T5 \geq dT5_ON$ and heat pump is within operating ambient temperature range, heat pump provides hot water to the DHW tank.

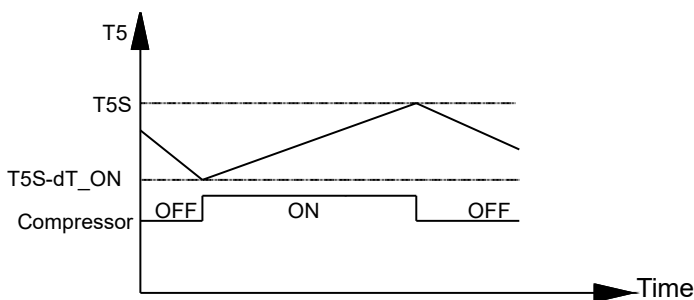

Abbreviations:

T5: DHW tank water temperature

T5S: DHW set temperature

7.3.1.6 dT1S5

Leaving water set temperature(T1S) for DHW mode is calculated by formula: $T1S = T5 + \Delta dT1S5 + dT1S5$

T1S: Leaving water set temperature

T5: DHW tank water temperature

$\Delta dT1S5$: Temperature modification value related to DHW tank water temperature(T5)

T5	$T5 < 30^\circ\text{C}$	$30^\circ\text{C} \leq T5 < 43^\circ\text{C}$	$43^\circ\text{C} \leq T5$
$\Delta dT1S5$	6	4	0

dT1S5: Temperature difference between leaving water set temperature and tank water temperature modification value.

7.3.1.7 T4DHWMAX, T4DHWMIN

T4DHWMAX defines the ambient temperature above which heat pump and AHS/IBH may have different actions.

When $T4DHWMAX \leq T4$ and $T4DHWMAX < 43$, both compressor and AHS/IBH stop running.

When $T4HMAX \leq T4$ and $T4DHWMAX = 43$, compressor runs with lowest frequency and AHS/IBH runs according to user demand.

T4DHWMIN defines the ambient temperature below which heat pump stops, while AHS/IBH/TBH can run if $dT1_AHS_ON/dT1_IBH_ON/dT5_ON$ is satisfied.

Diagram below illustrates the effects of **T4DHWMAX** and **T4DHWMIN**.

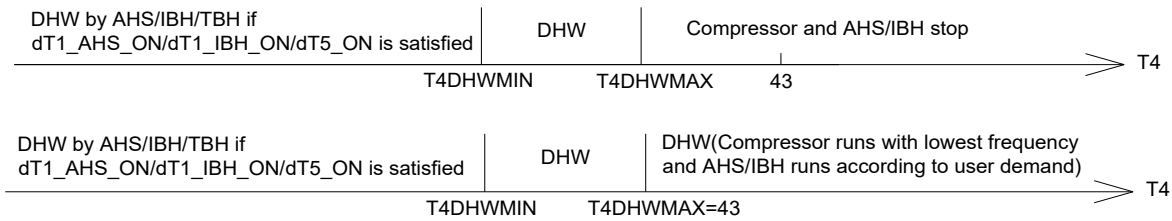

Abbreviations:

HP: Heat pump

TBH: DWH tank immersion heater

AHS: Auxiliary heating source

IBH: Electric heater

7.3.2 Cooling setting

Cooling setting		Cooling setting	
Cooling mode	YES	dT1SC	5°C
t_T4_FRESH_C	0.5 hours	dTSC	2°C
T4CMAX	52°C	Zone 1 C-emission	FCU
T4CMIN	10°C	Zone 2 C-emission	FCU

7.3.2.1 Cooling mode

Cooling mode defines whether space cooling demand is needed.

Setting	Description
YES	Enable cooling mode if space cooling terminals are installed.
NO	Disable cooling mode if space cooling terminals are not installed. In this case, no need to define other settings in Cooling mode , all other settings in Cooling mode will be invisible .

7.3.2.2 t_T4_FRESH_C

t_T4_FRESH_C defines the refresh cycle of detecting ambient temperature for climate curve.

7.3.2.3 T4CMAX, T4CMIN

T4CMAX defines ambient temperature above which heat pump operates with lowest compressor frequency.

T4CMIN defines ambient temperature below which heat pump not operates.

Diagram below illustrates the effects of **T4CMAX** and **T4CMIN**.

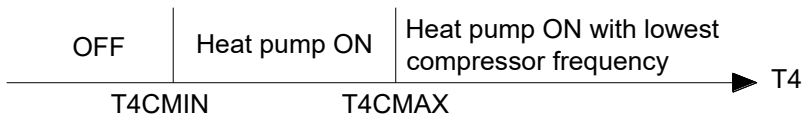

Abbreviations:

T4: Outdoor ambient temperature

7.3.2.4 dT1SC

dT1SC defines water temperature hysteresis of activating heat pump.

When $T1 - T1S \geq dT1SC$ and heat pump is within operating ambient temperature range, heat pump provides chilled water to space cooling terminals.

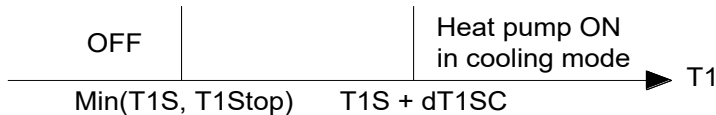

Abbreviations:

T1: Leaving water temperature

T1S: Leaving water set temperature

T1Stop: Leaving water temperature operating limit of cooling mode

7.3.2.5 dTSC

dTSC define room temperature hysteresis of activating heat pump. **dTSC** is only applicable if **YES** is selected for **Room temp.** in the **Temp. type setting**.

When $Ta - TS \geq dTSC$ and heat pump is within operating ambient temperature range, heat pump provides chilled water to space cooling terminals.

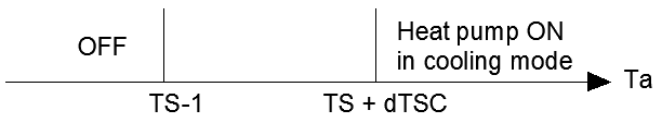

Abbreviations:

Ta: Actual room temperature

TS: Room setting temperature

7.3.2.6 Zone 1 C-emission, Zone 2 C-emission

Zone 1 C-emission defines the terminal type of zone 1.

Setting	Description
FCU	Fan coil unit
FLH	Floor heating loop
RAD	Radiator

Zone 2 C-emission defines the terminal type of zone 2.

Setting	Description
FCU	Fan coil unit
FLH	Floor heating loop
RAD	Radiator

7.3.3 Heating setting

Heating setting	
Heating mode	YES
t_DHWHP_MAX	0.5hours
PUMP_D_TIMER	25°C
PUMP_D_RUNNINGTIME	-15°C

Heating setting	
dT1SH	-5°C
dTSH	2°C
Zone 1 H-emission	RAD
Zone 2 H-emission	FLH

Heating setting	
Force defrost	NO

7.3.3.1 Heating mode

Heating mode defines whether space heating demand is needed.

Setting	Description
YES	Enable heating mode if space heating terminals are installed.
NO	Disable heating mode if space heating terminals are not installed. In this case, no need to define other settings in Heating mode , all other settings in Heating mode will be invisible.

7.3.3.2 t_T4_FRESH_H

t_T4_FRESH_H defines the refresh time of heating mode climate temperature curve.

7.3.3.3 T4HMAX, T4HMIN

T4HMAX defines the ambient temperature above which heat pump and AHS/IBH may have different actions.

When $T4HMAX \leq T4$ and $T4HMAX < 35$, both compressor and AHS/IBH stop running.

When $T4HMAX \leq T4$ and $T4HMAX = 35$, compressor runs at lowest frequency and AHS/IBH runs according to user demand.

T4HMIN defines the ambient temperature below which heat pump stops, while AHS/IBH can run if $dT1_AHS_ON/dT1_IBH_ON$ is satisfied.

Diagram below illustrates the effects of **T4HMAX** and **T4HMIN**.

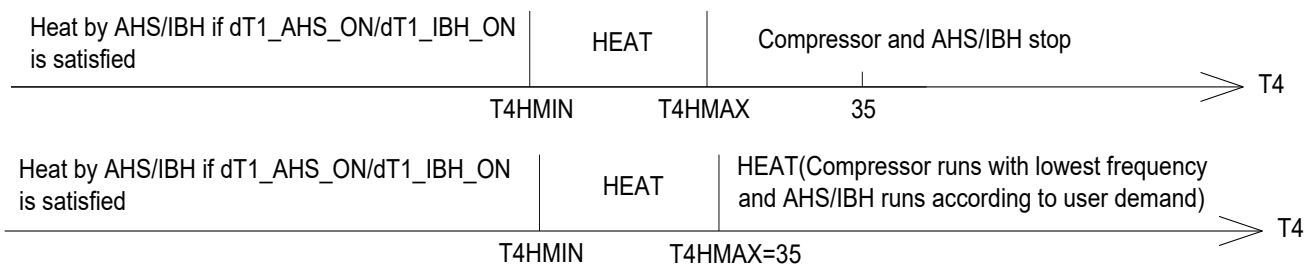

Abbreviations:

T4: Outdoor ambient temperature

AHS: Additional heating source

IBH: Internal backup heater

7.3.3.4 dT1SH

dT1SH defines water temperature hysteresis of activating heat pump.

When $T1 \leq T1S - dT1SH$ and heat pump is within operating ambient temperature range, heat pump provides hot water to the space heating terminals.

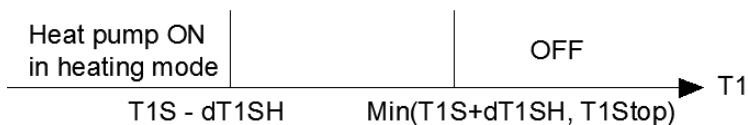

7.3.3.5 dTSH

dTSH defines room temperature hysteresis of stopping heat pump. **dTSH** is only applicable if **YES** is selected for **Room temp.** in the **Temp. type setting**.

When $TS - Ta \geq dTSH$ and heat pump is within operating ambient temperature range, heat pump provides hot water to the space heating terminals



Abbreviations:
 Ta: Actual room temperature
 TS: Room setting temperature

7.3.3.6 Zone 1 H-emission, Zone 2 H-emission

Zone 1 H-emission defines the terminal type of zone 1.

Setting	Description
FCU	Fan coil unit
FLH	Floor heating loop
RAD	Radiator

Zone 2 H-emission defines the terminal type of zone 2.

Setting	Description
FCU	Fan coil unit
FLH	Floor heating loop
RAD	Radiator

7.3.3.7 Force defrost

Force defrost enable heat pump enters defrost mode by manual operation when heat pump runs for 10min and air-side heat exchanger outlet temperature $T3 < 0^\circ\text{C}$ lasts for more than 6min.

Setting	Description
YES	Disable Force defrost function
NO	Enable Force defrost function

7.3.4 Auto mode setting

Auto mode setting	
T4AUTOCMIN	25°C
T4AUTOHMAN	17°C

7.3.4.1 T4AUTOCMIN, T4AUTOHMAX

T4AUTOCMIN defines the ambient temperature below which the heat pump will not provide chilled water for space cooling in auto mode.

T4AUTOHMAX defines the ambient temperature above which the heat pump will not provide hot water for space heating in auto mode.

Diagram below illustrates the effects of **T4AUTOCMIN**, **T4AUTOHMAX**, **T4CMAX** and **T4HMIN**.

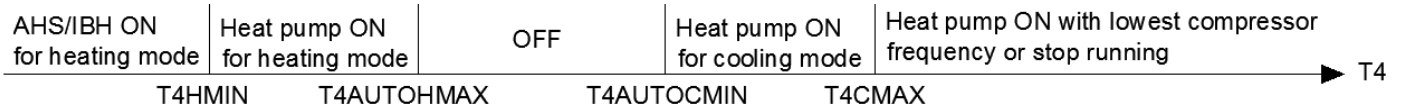

Abbreviations:

AHS: Additional heating source

IBH: Backup electric heater

T4CMAX: The ambient temperature above which heat pump operates with lowest compressor frequency.

T4HMIN: The ambient temperature below which the heat pump will not operate in heating mode.

7.3.5 Temp. type setting

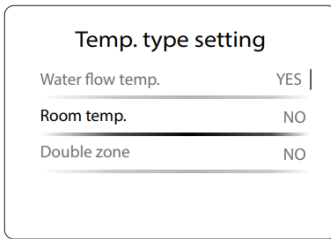

The **Temp. type setting** is used for selecting whether the water flow temperature or room temperature is used to control the ON/OFF of the heat pump. In this case, **7.3.6 Room thermostat setting** should be defined as NO.

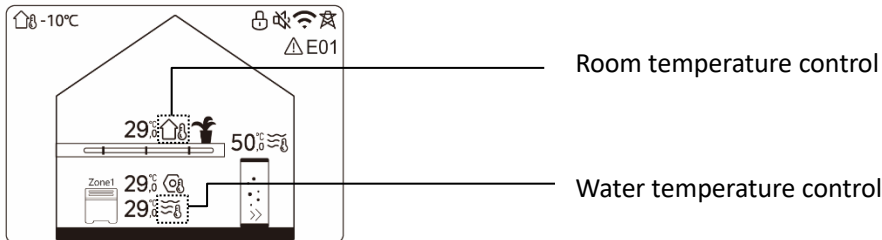

7.3.5.1 Water flow temp.

Water flow temp. defines whether heat pump is controlled by leaving water temperature.

Setting	Description
YES	Heat pump is controlled by leaving water temperature.
NO	Heat pump is not controlled by leaving water temperature.

7.3.5.2 Room temp.

Room temp. defines whether heat pump is controlled by room temperature detected by the temperature sensor inside the wired controller.

Setting	Description
YES	Heat pump is controlled by room temperature no matter what is the setting of 7.3.5.1 Water flow temp. In this case, the target water flow temperature will be calculated from climate curves.
NO	Heat pump is not controlled by room temperature.

7.3.5.3 Double zone

Double zone defines the number of zones.

Setting	Description
YES	Double zones control
NO	Single zone control

Figure below illustrates the effects of different combinations in **Temp. type setting**.

For single zone control

WATER FLOW TEMP.	ROOM TEMP.	DOUBLE ZONE	Zones control
YES	NO	NO	Zone 1: Water temperature control
NO	YES	NO	Zone 1: Room temperature control

For double zone control

WATER FLOW TEMP.	ROOM TEMP.	DOUBLE ZONE	Zones control
YES	YES	YES	Zone 1: Water temperature control
			Zone 2: Room temperature control
YES	NO	YES	Zone 1: Water temperature control
			Zone 2: Water temperature control

7.3.6 Room thermostat setting

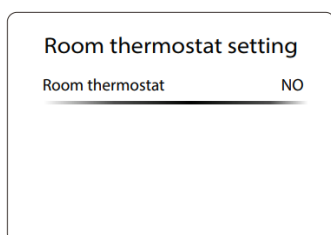

Room thermostat can be as an alternative solution to control heat pump.

Setting	Description	Wired controller is used to
NO	<ul style="list-style-type: none"> NON Without room thermostats(means Temp. type setting is valid) 	<ul style="list-style-type: none"> Control heat pump ON/OFF Define water temperature Define mode (heating/ cooling/ auto mode)
MODE SET	<ul style="list-style-type: none"> MODE SET Room thermostat provides separate heating/cooling switch signal to control heat pump ON/OFF One zone control All timers are invalid except DHW timers. 	<ul style="list-style-type: none"> Define water temperature
ONE ZONE	<ul style="list-style-type: none"> ONE ZONE Room thermostat provides switch signal to control heat pump ON/OFF One zone control All timers are invalid except DHW timers. 	<ul style="list-style-type: none"> Define water temperature Define mode(heating/cooling mode)
DOUBLE ZONE	<ul style="list-style-type: none"> DOUBLE ZONE Room thermostat provides switch signal to control heat pump ON/OFF Double zones control All timers are invalid except DHW timers. 	<ul style="list-style-type: none"> Define water temperature Define mode(Only for heating mode)

If **Room thermostat setting** is defined as MODE SET, the interface appears:

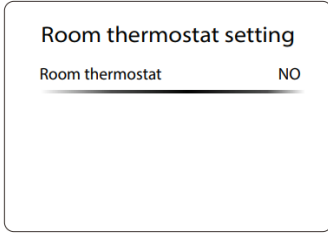

Mode set priority defines whether cooling mode or heating mode takes priority.

Setting	Description
Heating	When heating and cooling switch signal are closed simultaneously, heat pump runs in heating mode.
Cooling	When heating and cooling switch signal are closed simultaneously, heat pump runs in cooling mode.

7.3.7 Other Heat Source Menu

Other heat source

IBH function Heating and DHW |

dT1_IBH_ON 5°C

t_IBH_DELAY 15minutes

T4_IBH_ON -5°C

Other heat source

P_IBH1 0.0kW |

P_IBH2 0.0kW

AHS_function Heating

AHS_PUMPI CONTROL Run

Other heat source

dT1_AHS_ON 5°C |

t_AHS_DELAY 30minutes

T4_AHS_ON -5°C

EnSwitchPDC NO

Other heat source

GAS-COST 0.85 |

ELE-COST 0.20

MAX-SETHEATER 80°C

MIN-SETHEATER 30°C

Other heat source

MAX-SIGHEATER 10V |

MIN-SIGHEATER 3V

TBH FUNCTION YES

dT5_TBH_OFF 5°C

Other heat source

t_TBH_DELAY 30minutes |

T4_TBH_ON 5°C

P_TBH 2.0kW

Solar function Solar and HP

Other heat source

Solar control SL1SL2 |

Deltatsol 10°C

7.3.7.1 IBH FUNCTION, dT1_IBH_ON, t_IBH_DELAY, T4_IBH_ON, P_IBH1, P_IBH2

IBH FUNCTION defines backup heater function.

Setting	Description
YES	IBH is used for heating mode
NO	IBH is used for heating mode and DHW mode

dT1_IBH_ON defines water temperature hysteresis of activating electric heater. When $T1S - T1 \geq dT1_IBH_ON$ the backup electric heater is on.

T1S: Heat pump leaving water set temperature

T1: Heat pump leaving water temperature

t_IBH_DELAY defines the delayed start-up time of electric heater. Electric heater will turn on **t_IBH_DELAY** minutes later after compressor starts.

T4_IBH_ON defines the ambient temperature below which the backup electric heater is on.

Note: Only when dT1_IBH_ON, t_IBH_DELAY and T4_IBH_ON are met at the same time then electric heater turns on.

Diagram below illustrates the effects of **T4_IBH_ON**, **T4HMIN** and **T4HMAX**.

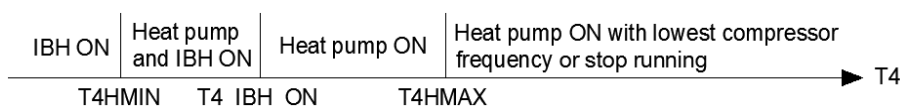

Abbreviations:

M thermal Nature Plus Series

T4: Outdoor ambient temperature

IBH: Electric heater

T4HMIN: The ambient temperature below which the heat pump will not operate in heating mode.

T4HMAX: The ambient temperature above which the heat pump will operate heating mode with lowest compressor frequency.

P_IBH1 defines heating capacity of IBH1, which is used for energy consumption statistics.

P_IBH2 defines heating capacity of IBH2, which is used for energy consumption statistics.

7.3.7.2 AHS FUNCTION, AHS_PUMP_I CONTROL, dT1_AHS_ON, t_AHS_DELAY, T4_AHS_ON

AHS FUNCTION defines auxiliary heating source function.

Setting	Description
NO	Without Auxiliary heating source
Heating	Auxiliary heating source is used for heating mode
Heating and DHW	Auxiliary heating source is used for heating mode and DHW mode

AHS_PUMP_I CONTROL select the Pump_I operating status when only auxiliary heating source runs.

Setting	Description
Run	Pump_I runs when auxiliary heating source runs only.
Not run	Pump_I does not run when auxiliary heating source runs only. In this case, please confirm there is an additional pump running for auxiliary heating source.

dT1_AHS_ON defines water temperature hysteresis of activating auxiliary heating source. When $T1S - T1 \geq dT1_AHS_ON$ the additional heating source is on.

T1S: Heat pump leaving water set temperature

T1: Heat pump leaving water temperature

t_AHS_DELAY defines the delayed start-up time of auxiliary heating source. Auxiliary heating source will turn on **t_AHS_DELAY** minutes later after compressor starts.

T4_AHS_ON defines the ambient temperature below which the auxiliary heating source is on.

Note: Only when **dT1_AHS_ON**, **t_AHS_DELAY** and **T4_AHS_ON** are met at the same time then auxiliary heating source turns on.

Diagram below illustrates the effects of **T4_AHS_ON**, **T4HMIN** and **T4HMAX**.

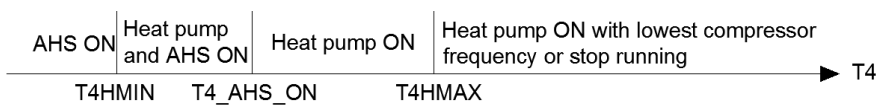

Abbreviations:

T4: Outdoor ambient temperature

AHS: Auxiliary heating source

T4HMIN: The ambient temperature below which the heat pump will not operate in heating mode.

T4HMAX: The ambient temperature above which the heat pump will operate heating mode with lowest compressor frequency.

7.3.7.3 EnSWITCHPDC, GAS_COST, ELE_COST

EnSWITCHPDC defines whether heat pump and additional heating source switch automatically based on economic performance and system high efficiency.

Setting	Description
NO	Disable EnSWITCHPDC function, T4_AHS_ON need to be defined manually. Additional heating source may work

	with heat pump depends on the water temperature and heat pump status.
YES	Enable EnSWITCHPDC function, T4_AHS_ON is calculated according to price of gas and electricity and the efficiency of boiler and heat pump. Only Additional heating source works at ambient temperature of T4_AHS_ON because of the economic performance and system high efficiency.

GAS_COST defines gas price

ELE_COST defines electricity price

7.3.7.4 MAX_SETHEATER, MIN_SETHEATER, MAX_SIGHEATER, MIN_SIGHEATER

When “AHS1” port and “AHS2” port of main control PCB are connected with auxiliary heating source “ON/OFF” signal, auxiliary heating source leaving water temperature automatically change as voltage changes.

MAX_SETHEATER sets the maximum water temperature of auxiliary heating source.

MIN_SETHEATER sets the minimum water temperature of auxiliary heating source.

MAX_SIGHEATER sets the voltage corresponding to the maximum water set temperature of auxiliary heating source.

MIN_SIGHEATER sets the voltage corresponding to the minimum water set temperature of auxiliary heating source.

Diagram below illustrates the effects of **MAX_SETHEATER**, **MIN_SETHEATER**, **MAX_SIGHEATER** and **MIN_SIGHEATER**.

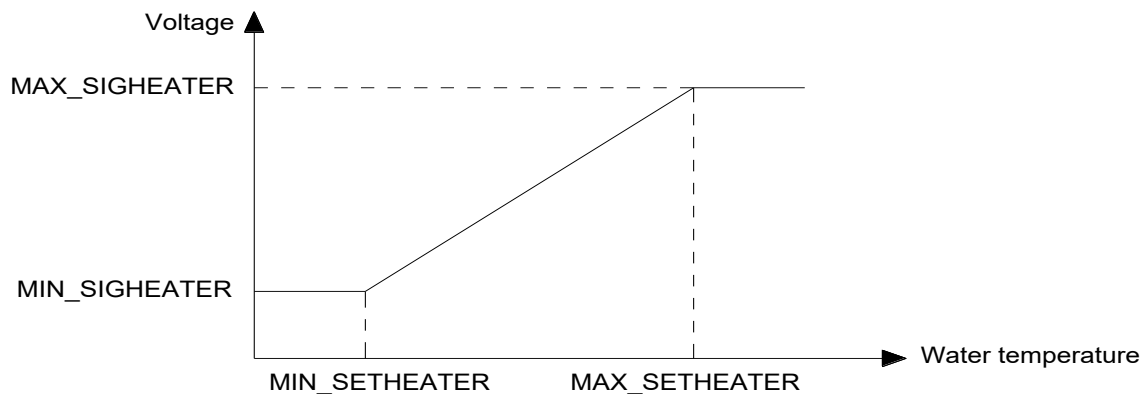

7.3.7.5 TBH FUNCTION, dT5_TBH_OFF, t_TBH_DELAY, T4_TBH_ON, P_TBH

TBH FUNCTION defines whether tank booster heater function is activated.

Setting	Description
YES	Disable tank booster heater function
NO	Enable tank booster heater function

dT5_TBH_OFF defines water temperature hysteresis of inactivating tank booster heater when heat pump malfunctions.

When $T5 > \text{Min}(T5S + dT5_TBH_OFF, 70^\circ\text{C})$, the tank booster heater is off.

T5S: Domestic hot water tank set temperature

t_TBH_DELAY defines the delayed start-up time of tank booster heater. Tank booster heater will turn on **t_TBH_DELAY** minutes later after compressor starts.

T4_TBH_ON defines the ambient temperature below which the tank booster heater is on.

M thermal Nature Plus Series

Note: Only when t_TBH_DELAY , $T4_TBH_ON$ are met at the same time then tank booster heater turns on.

P_TBH defines the power input of tank booster heater, which is used for energy consumption statistics.

Diagram below illustrates the operation of heat pump and tank booster heater of DHW mode.

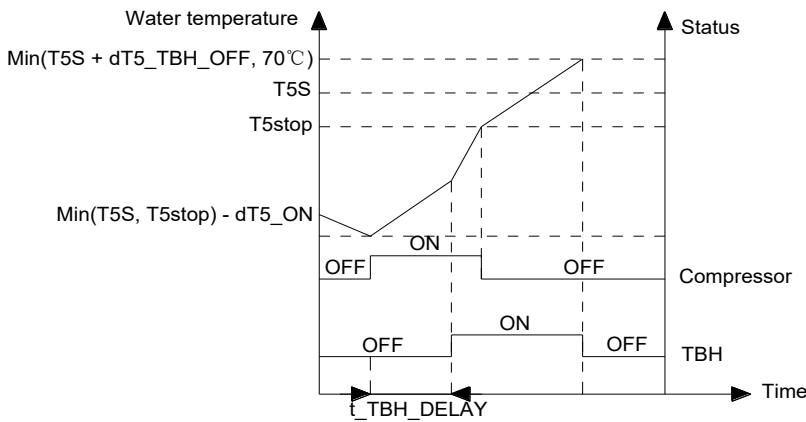

Abbreviations:

T5S: DHW set temperature

T5stop: DHW mode leaving water temperature operating limit

TBH: Immersion heater

7.3.7.6 Solar function, Solar control, Deltasol

Solar function defines whether the heating system is equipped with solar function.

Setting	Description
NO	Without solar function.
Solar and HP	With solar function and heat pump.
Only solar	With only solar function.

Solar control defines the control type of solar pump

Setting	Description
Tsolar	Solar pump(Pump_S) is controlled by solar temperature sensor
SL1SL2	Solar pump(Pump_S) is controlled by SL1SL2 signal

Deltasol defines temperature hysteresis of activating solar pump(Pump_s).

When $T_{solar} > T5 + Deltasol$, $T5 < 79^{\circ}C$ and DHW mode is ON, then solar pump activates.

7.3.8 Service call

Service call

Phone number 0000000000000000

Mobile number 0000000000000000

Phone number and **Mobile number** define after-sales service contact numbers. Press $\langle \rangle$ to navigate cursor and press $\wedge \vee$ to adjust the numerical values. The maximum length of the phone numbers is 15 digits.

7.3.9 Restore factory settings

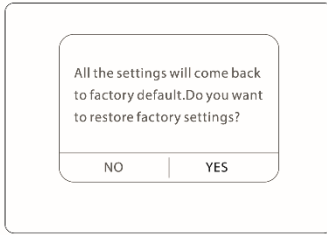

Restore factory settings is used to restore all the parameters (including energy metering data and WLAN setting) set in the user interface to factory defaults.

On selecting YES, the process of restoring all settings to factory defaults begins and progress is displayed as a percentage.

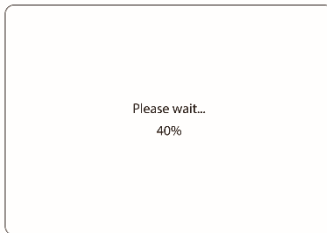

7.3.10 Test run

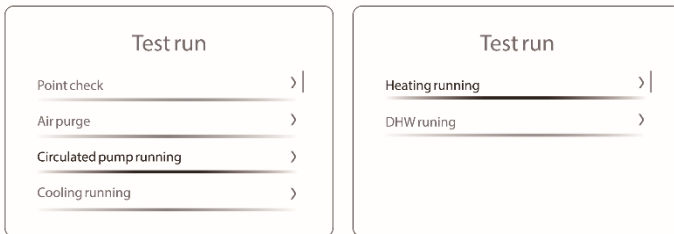

Test run is used to do the point check and check that air purge function, circulation pump, cooling mode, heating mode and DHW mode are all operating correctly. If any error code is displayed during the test run operation, the cause should be investigated.

During test run, all buttons except are invalid. If you want to turn off the test run, please press . For example, when the unit is in air purge mode, after you press , the following page will be displayed:

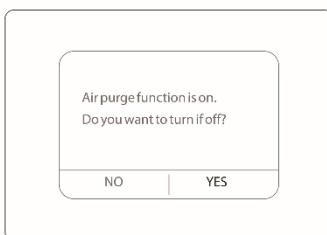

7.3.10.1 Point check

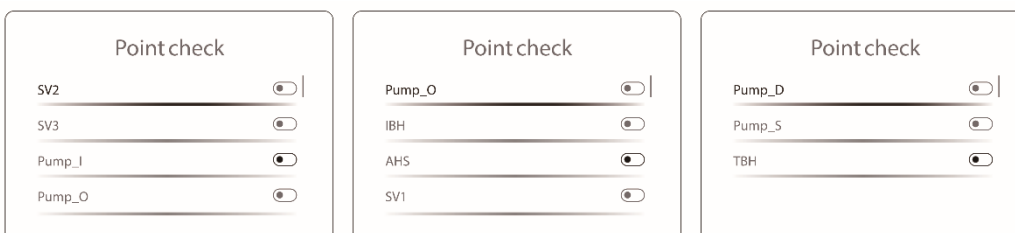

The **POINT CHECK** menu is used to check the operation of individual components. Use to scroll to the components you want to check and press to toggle the on/off state of the component. If a valve does not turn on/off or a pump/heater does not operate when their on/off state is toggled, please check the connection between component and main PCB and make sure components' status is normal.

7.3.10.2 Air purge

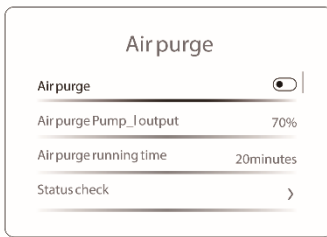

Once installation is complete, it is important to run the air purge function to remove any air which may be present in the water piping and which could cause malfunctions during operation. Before running **Air purge** mode, make sure that the air purge valve is open. Pump_I will run according to the output and running time that has been set.

Air purge defines whether the function is activated.

Air purge Pump_I output defines the Pump_I output capacity.

Air purge running time defines the period that Pump_I operates during the air purge process.

Status check allows installers to check the real-time operation parameters of air purge operation.

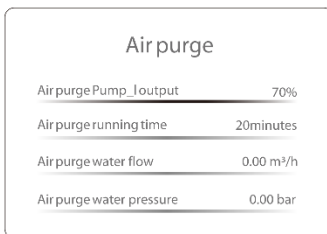

7.3.10.3 Circulated pump running

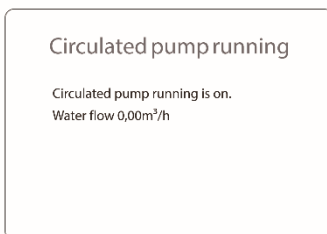

Circulated pump running operation is used to check the operation of the circulation pump.

When circulation pump running is turned on, all running components will stop.

Circulated pump running operation is used to check the operation of the circulation pump.

When circulation pump running is turned on, all running components will stop.

When the unit received signal that indicates Circulated pump running =ON:

- SV1 will be on after 30 secs;
- Pump_I will be on after 60 secs.
- Pump_I will be off after 240 secs.
- SV1 will be off and the SV2 will be on after 270 secs.
- Pump_I & pump_O will be on after after 30 secs

If E8 occurs during these processes, the unit will stop Circulated pump running mode immediately

7.3.10.4 Cooling running

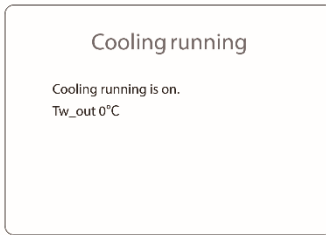

The **Cooling running** operation is used to check the operation of the system in space cooling mode.

During the **Cooling running** operation, the leaving water set temperature is 7°C. The current actual leaving water temperature is displayed on the user interface. The unit operates until the leaving water temperature drops to the set temperature or the next command is received.

7.3.10.5 Heating running

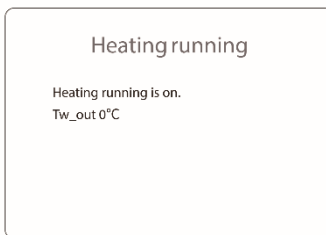

The **Heating running** operation is used to check the operation of the system in space heating mode.

During **Heating running** test running, the default target outlet water temperature is 35°C. The IBH (backup heater) will turn on after the compressor runs for 10 min. After the IBH runs for 3 minutes, the IBH will turn off. Heat pump will operate until the water temperature increase to a certain value or the next command is received.

7.3.10.6 DHW running

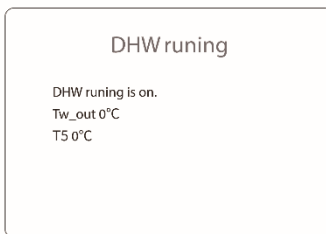

The **DHW running** operation is used to check the operation of the system in DHW mode.

During **DHW running** test running, the default target temperature of the domestic water is 55°C. The TBH (tank boost heater) will turn on after the compressor runs for 10min. The TBH will turn off 3 minutes later. Heat pump will operate until the water temperature increase to a certain value or the next command is received.

7.3.11 Special Function



7.3.11.1 Preheating for floor

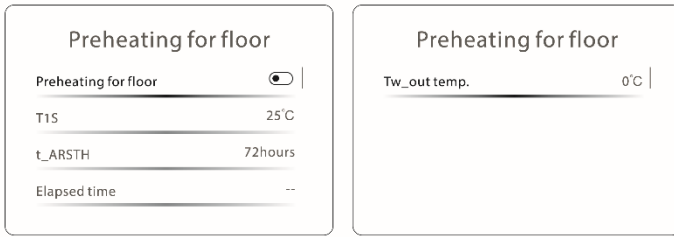

Preheating for floor function provides mild heat to the underfloor water piping for the first time during seasonal heating, diminish the risk of damage to the floor and piping system.

Setting	Description
0	Disable preheating for floor function
1	Enable preheating for floor function

T1S defines heat pump leaving water temperature in preheating.

T_ARSTH defines running time for first preheating of the floor

Elapsed time is the period that **Preheating for floor function** had run.

Tw_out temp. is the current leaving water temperature

Diagram below illustrates the operation of **Preheating for floor** function.

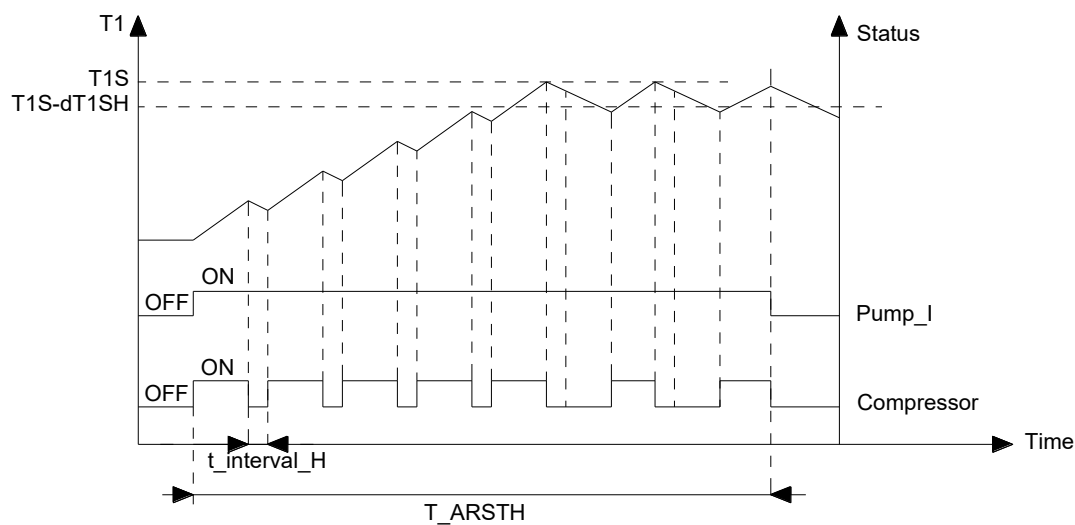

Abbreviations:

T1: Leaving water temperature

dT1SH: Water temperature hysteresis of activating heat pump.

t_interval_H: The delayed start-up time of compressor in heating mode.

7.3.11.2 Floor drying up

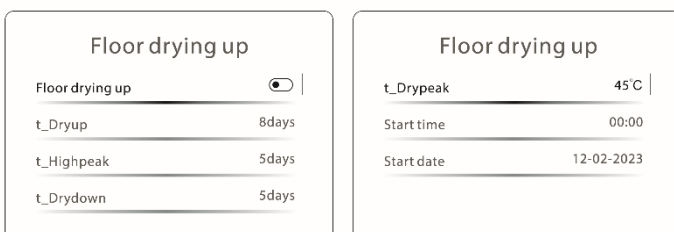

For newly-installed under-floor heating systems, floor drying up is necessary to remove moisture from the floor slab and subfloor to prevent warping or rupture of the floor. Heat pump provides mild heat to the concrete or other structural material

around the underfloor water piping in a certain period of time, accelerate the process of getting rid of moisture. During floor drying up operation, the temperature of the floor would be increased gradually. In the event of a heat pump malfunction, floor drying up mode will continue if a backup electric heater and/or auxiliary heating source is available and configured to support space heating mode.

There are three phases to the floor drying up operation:

- Phase 1: gradual temperature increase to the peak temperature
- Phase 2: maintain peak temperature
- Phase 3: gradual temperature decrease from the peak temperature

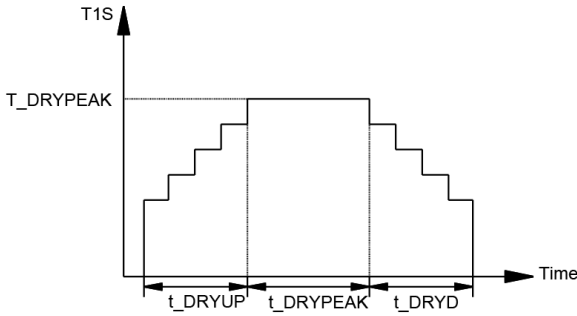

Floor drying up

Setting	Description
0	Disable floor draying up function
1	Enable floor draying up function

t_Dryup defines the duration of Phase 1.

t_Highpeak defines the duration of Phase 2.

t_Drydown defines the duration of Phase 3.

t_Drypeak defines the heat pump leaving water temperature of Phase 2.

Start time defines the floor drying up operation start time.

Start date defines the floor drying up operation start date.

7.3.12 Auto restart

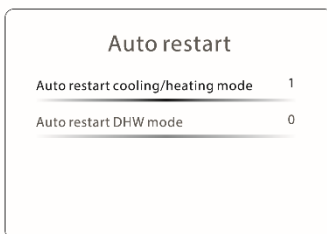

Auto restart sets whether or not the unit re-applies the mode and unit status settings when the power returns following a power failure.

If **7.3.6 Room thermostat setting** is defined as not 0, **Auto restart function** will not be applicable.

Auto restart cooling/heating mode

Setting	Description
NO	Disable auto restart cooling/heating mode
YES	Enable auto restart cooling/heating mode

Auto restart DHW mode

Setting	Description
NO	Disable auto restart DHW mode
YES	Enable auto restart DHW mode

7.3.13 Power input limitation

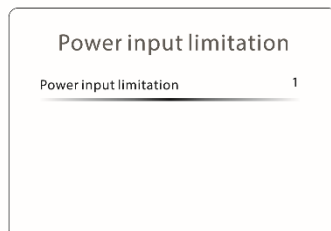

Power input limitation makes the machine suitable for a variety of current supplies. There are 8 configurations for user to choose according to the maximum allowable access current. If the unit will operate at larger current input, 1 should be selected. If the unit will operate at a lower current input, 2-8 should be selected and the power input and capacity will decrease.

Power limitation function

Setting	Model			
	Single phase 8~10kW	Three phase 8~10kW	Single phase 12~16kW	Three phase 12~16kW
1	19.5A	6.5A	29.5A	10A
2	18A	6A	26A	8.5A
3	16.5A	5.5A	24A	7.5A
4	15A	5A	22A	7A
5	13.5A	4.5A	20A	6.5A
6	12A	4A	18A	6A
7	12A	4A	18A	6A
8	12A	4A	18A	6A

7.3.14 Input definition

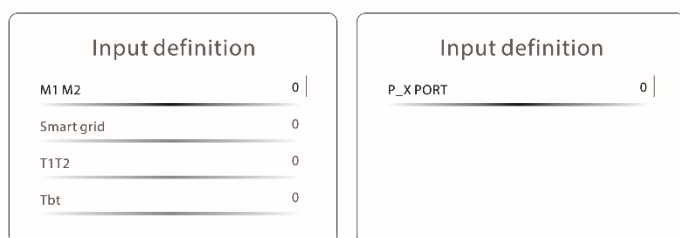

INPUT DEFINE defines sensors and functions to fulfill with installation.

M1 M2 defines the function of M1M2 port

Setting	Description
Remote ON/OFF	Remote ON/OFF control of heat pump
TBH ON/OFF	Remote ON/OFF control of tank booster heater
AHS ON/OFF	Remote ON/OFF control of auxiliary heating source

Smart grid defines whether SMART GRID control signal is connected to hydronic PCB.

Setting	Description
NO	Disable Smart grid function
YES	Enable Smart grid function

T1T2 defines control options of Port T1T2

Setting	Description
NO	Installation with MH-kit
RT/Ta_PCB	Installation without MH-kit

Tbt defines whether balance tank temperature sensors are installed in the balance tank.

Setting	Description
NO	Installation with balance tank temperature sensor(Tbt)
YES	Installation without balance tank temperature sensor(Tbt)

P_X PORT can be defined as defrosting signal or alarm signal according to customers' demand.

Setting	Description
Defrost	Defrosting signal
Alarm	Alarm signal

7.3.15 Cascade setting

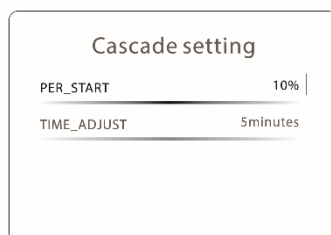

PER_START sets the start-up percentage of multiple units for the first time start-up after power on. For example:

Total units	PER_START	Starting units
6	50%	3
6	30%	2

TIME_ADJUST sets the judgment period of adding and subtracting units

7.3.16 HMI address setting

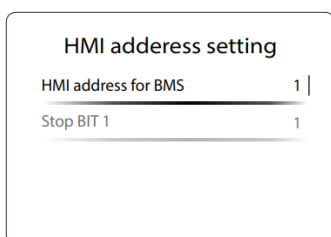

HMI ADDRESS FOR BMS sets the HMI address code for BMS.(only valid for master controller)

STOP BIT set upper computer stop bit(1: STOP BIT1; 2:STOP BIT2)

Setting	Description
1	Stop bit 1
2	Stop bit 2

7.3.17 Common setting

Common setting		Common setting		Common setting	
t_DELAY PUMP	2.0minutes	t2-ANTILOCK SV RUN	30seconds	Pump_O	Auto
t1_ANTILOCK PUMP	24hours	Ta-adj.	-2°C		
t2_ANTILOCK PUMP RUN	60seconds	PUMP_I SILENT OUTPUT	100%		
t1-ANTILOCK SV	24hours	Energy metering	YES		

7.3.17.1 t_DELAY PUMP

t_DELAY PUMP defines the delayed stop time of Pump_I. Pump_I will stop **t_DELAY PUMP** minutes later after compressor stops base on system temperature equalization consideration.

7.3.17.2 t1_ANTILOCK PUMP, t2_ANTILOCK PUMP RUN, t1_ANTILOCK SV, t2_ANTILOCK SV RUN

Antilock operation prevent components from sticking to result in system fail.

t1_ANTILOCK PUMP defines the interval time that Pump_I, Pump_O and Pump_C runs in order to antilock

t2_ANTILOCK PUMP RUN defines the running time for Pump_I, Pump_O and Pump_C antilock operation

t1_ANTILOCK SV defines the interval time that SV1, SV2 and SV3 valve works in order to antilock

t2_ANTILOCK SV RUN defines the running time for SV1, SV2 and SV3 valve antilock operation

7.3.17.3 Ta-adj

Ta-adj is an correction value for room temperature sensor(Ta) which is inside the wired controller. The display room temperature value is equal to Ta + **Ta-adj**.

7.3.17.4 PUMP_I_SLIENT OUTPUT

PUMP_I_SLIENT OUTPUT can decrease water pump maximum output in order to decrease the noise of heat pump.

7.3.17.5 Energy metering

Energy metering allows user to check energy data of day, week, month and year.

Setting	Description
NO	Disable energy metering function
YES	Enable energy metering function

7.3.17.6 Pump_O

Pump_O defines Zone 1 pump(**Pump_O**) control type.

Setting	Description
ON	Pump_O keeps running
Auto	Pump_O operation is controlled by heat pump

7.3.18 Clear energy data

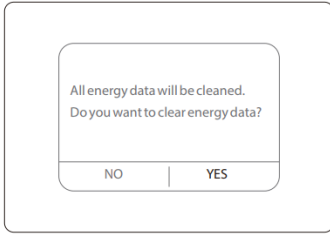

Once selecting YES, All energy metering data is clear.

7.3.19 Intelligent function settings

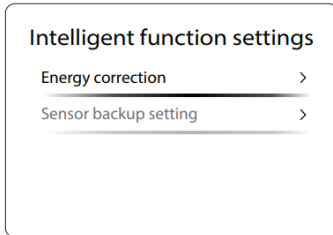

7.3.19.1 Energy correction

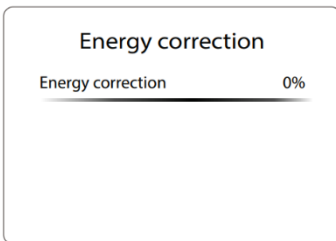

The actual installation scenario would be different from one to another. The energy metering calculation of the unit could deviate slightly due to the actual installation.

Energy correction is to offset the deviation of the energy metering calculation of the unit. Value from -50% to 50%, default is 0. It is applied for Heating, Cooling and DHW.

The final energy data = original data * (1+ **Energy correction**)

7.3.19.2 Sensor backup setting

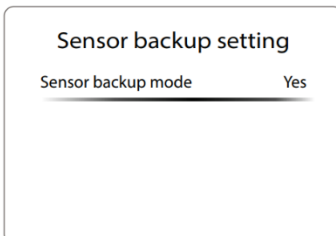

Sensor backup setting defines whether the sensor backup function is active or not.

Setting	Description
NO	Disable Sensor backup setting function
YES	Enable Sensor backup setting function

When Sensor backup setting function is activated, a bubble with text jumps out in the home page, in which the timer indicates for how long the unit can run normally before it shuts down.

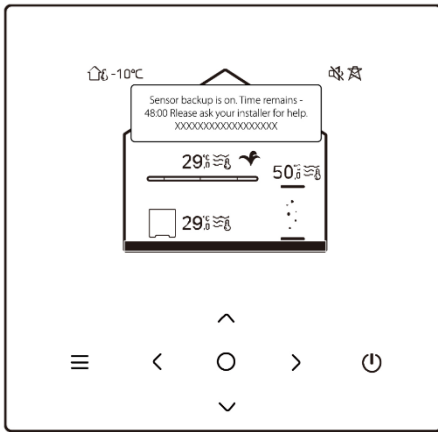

If Sensor backup setting function is stopped, the bubble will hide automatically. If the timer runs out, the bubble hides and unit will shut down due to the existed error.

In cascade installation, Sensor backup setting function is available for master unit only.

7.3.20 C2 fault restore

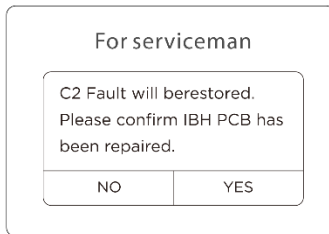

For the unit with IBH(internal backup heater), when C2 error occurs, please follow C2 troubleshooting guide of Part4 Diagnosis and Troubleshooting. If necessary, select YES to restore C2 code.

7.4 Operation parameter

Operation parameter is for reviewing the operation parameters. The interface below is for reference and different units' state correspond to different parameter values.

Operation for entering **Operation parameter**:

Step 1: Home page

Step 2: Press “≡”

Step 3: Select “Unit status”

Step 4: Select “Operation parameter”

Step 5: Press ○

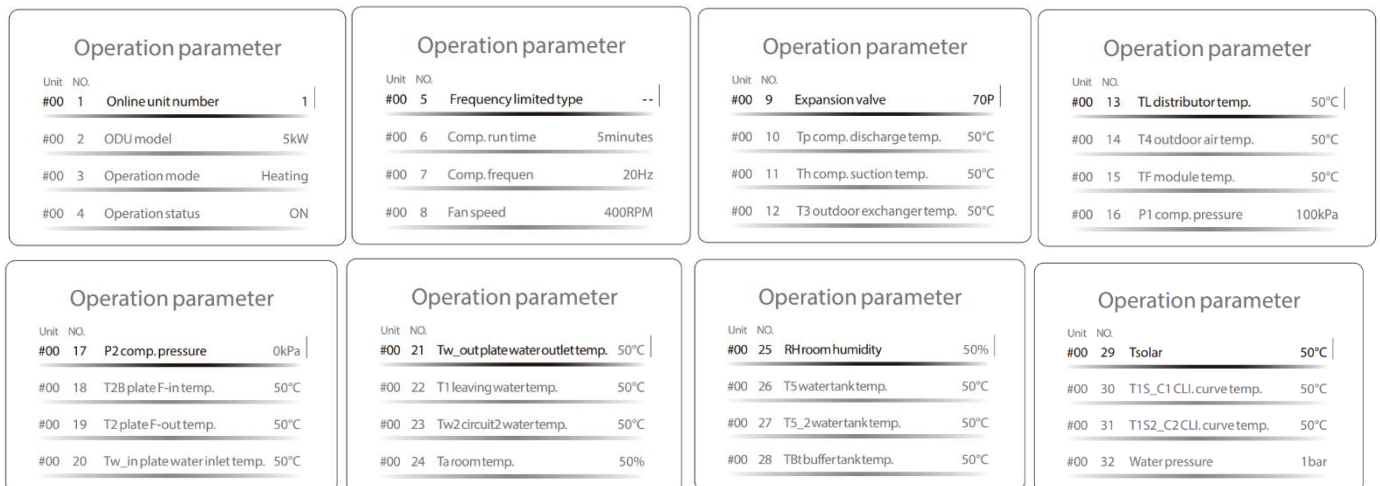

Operation parameter

Unit	NO.	Parameter	Value
#00	33	Waterflow	1m ³ /h
#00	34	Heat pump capacity	10kW
#00	35	ODU current	1A
#00	36	ODU voltage	220V

Operation parameter

Unit	NO.	Parameter	Value
#00	37	DC voltage	110V
#00	38	DC current	5A
#00	39	Power consump.	10kWh
#00	40	SV1	OFF

Operation parameter

Unit	NO.	Parameter	Value
#00	41	SV2	OFF
#00	42	SV3	OFF
#00	43	Pump_I	OFF
#00	44	Pump_O	OFF

Operation parameter

Unit	NO.	Parameter	Value
#00	45	Pump_C	OFF
#00	46	Pump_S	OFF
#00	47	Pump_D	OFF
#00	48	IBH1	OFF

Operation parameter

Unit	NO.	Parameter	Value
#00	49	IBH2	OFF
#00	50	TBH	OFF
#00	51	AHS	OFF
#00	52	Comp. total run time	100h

Operation parameter

Unit	NO.	Parameter	Value
#00	53	Fan total run time	100h
#00	54	Pump_I total run time	100h
#00	55	IBH1 total run time	100h
#00	56	IBH2 total run time	100h

Operation parameter

Unit	NO.	Parameter	Value
#00	57	TBH total run time	100h
#00	58	AHS total run time	100h
#00	59	Pump_I PWM	70%
#00	60	Tp_calc	50°C

Operation parameter

Unit	NO.	Parameter	Value
#00	61	Th_calc	50°C
#00	62	T3_calc	50°C
#00	63	TL_calc	50°C
#00	64	T4_calc	50°C

Operation parameter

Unit	NO.	Parameter	Value
#00	65	P1_calc	100kPa
#00	66	P2_calc	100kPa

8 USB Function Field Settings

USB function helps you to transmit parameters and program easily. When USB disk connect to CN4 port of main control PCB, the USB function interface appears automatically on the wired controller.

Main control PCB



CN4 USB port

USB function interface

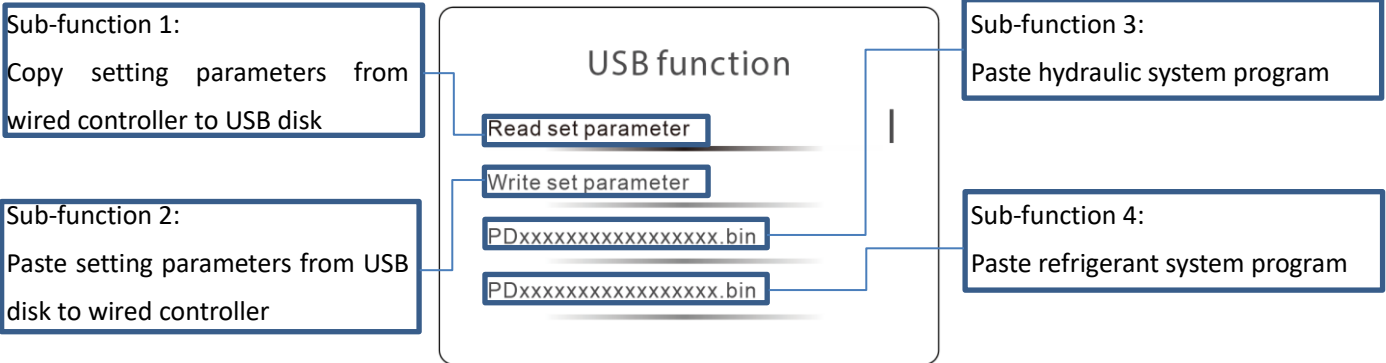

Sub-function 1:

Once the process finishes successfully, the parameter file “M_Thermal_Config(Prohibit to rewrite).csv” will be generated in the USB disk. If you want to change the parameter on computer, please remember only change the value of column C (red frame below) is allowed and do not change any other content or the file name.

Index	Parameter Name	Value	D	E	F	G	H	I	J	K	L	M
3	dT5_on	5										
4	t_interval_DHW	5										

Sub-function 2:

Please make sure there is only one parameter file in the USB disk before using this function.

Sub-function 3:

Please make sure there is only one applicable hydraulic system program in the USB disk before using this function.

Sub-function 4:

Please make sure there is only one applicable refrigerant system program in the USB disk before using this function.

Press \wedge \vee to choose the item and press \circ to confirm your choice, then the rate of process appears like below:

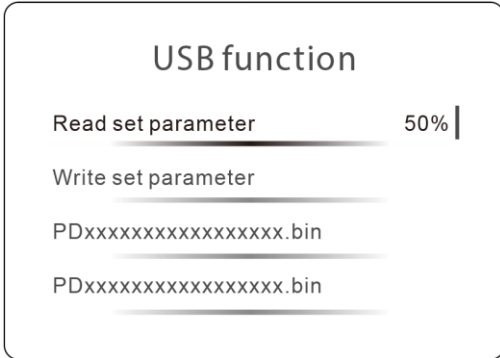

During the process, all the buttons are invalid.

When the process finishes, pop-up window with “Success” cue word appears briefly and unit stops. Please remove the USB disk and restart the unit.

When the process fails, pop-up window with “Fail” cue word appears briefly. The system program remains unchanged.

If the stalled process happens, please remove the USB disk and try to insert the USB disk according to operation above.

Part 4

Diagnosis and Troubleshooting

1 Service Information.....	59
2 Electric wiring diagram.....	67
3 Electric Control Box Layout.....	72
4 Outdoor Unit PCBs	75
5 Error Code Table.....	84
6 Troubleshooting	87
7 Discharge / Suction pressure and temperature range	152
8 Appendix to Part 4	153

1 Service Information

DANGER!

- These instructions are exclusively intended for qualified contractors and authorized installers
- Work on the refrigerant circuit with flammable refrigerant in safety group A3 may only be carried out by authorized heating contractors. These heating contractors must be trained in accordance with EN 378 Part 4 or IEC 60335-2-40, Section HH. The certificate of competence from an industry accredited body.
- Brazing/soldering work on the refrigerant circuit may only be carried out by contractors certified in accordance with ISO 13585 and AD 2000, Datasheet HP 100R. And only by contractors qualified and certified for the processes to be carried out. The work must fall within the range of applications purchased and be carried out in accordance with the prescribed procedures. Soldering/brazing work on accumulator connections requires certification of personnel and processes by a notified body according to the Pressure Equipment Directive (2014/68/EU).
- Work on electrical equipment may only be carried out by a qualified electrician.
- Before initial commissioning, all safety relevant points must be checked by the particular certified heating contractors. The system must be commissioned by the system installer or a qualified person authorized by the installer.

1.1 Label for Refrigerant Presence

Equipment should be provided with a label stating that it has been de-commissioned and emptied of refrigerant. The label should be dated and signed. Ensure that proper labels are pasted on the equipment stating the equipment contains flammable refrigerant

1.2 Leak Detection Methods

The following leak detection methods are deemed acceptable for systems containing flammable refrigerants. An electronic leak detector should be used to detect flammable refrigerants, but its sensitivity may not be adequate, or the detector may need re-calibration. (Detection equipment should be calibrated in a refrigerant-free area.) Ensure that the detector is not a potential source of ignition and is suitable for the refrigerant. Leak detection equipment should be set at a percentage of the LFL of the refrigerant and should be calibrated to be suitable for the refrigerant employed. The appropriate percentage of gas (25% maximum) is confirmed. Leak detection fluids are suitable for use with most refrigerants but detergents containing chlorine should not be used as the chlorine may react with the refrigerant and corrode the copper pipes. If a leak is suspected, all naked flames should be removed or extinguished. If a leakage of refrigerant is found and brazing is required, all of the refrigerant should be recovered from the system, or isolated (by means of shut off valves) in a part of the system that is remote from the leak. Oxygen free nitrogen (OFN) should then be purged through the system both before and during the brazing process.

1.3 Check of Refrigeration Equipment

Where electrical components are to be changed, they should be fit for the intended purpose and comply with the correct specifications. Always follow the manufacturer's maintenance and service guidelines. In case of any doubt, consult the manufacturer's technical department for assistance. Check installations using flammable refrigerants.

- The amount of refrigerant to be charged depends on the size of the room where the refrigerant-containing parts are installed.
- The ventilation machinery and outlets should work adequately and be not obstructed.
- If an indirect refrigerating circuit is used, the secondary circuits should be checked for any refrigerant; Markings on the equipment should be visible and legible.
- Illegible markings and signs should be corrected.
- Refrigeration pipes or components should be installed in positions where they are unlikely to be exposed to any

substance that may corrode refrigerant-containing components, unless the components are constructed of materials that are inherently resistant to corrosion or are suitably protected from corrosion

1.4 Check of Electrical Devices

Repair and maintenance of electrical components should include initial safety checks and component inspection procedures. If a fault exists and could compromise safety, no electrical supply should be connected to the circuit until it is satisfactorily dealt with. If the fault cannot be corrected immediately but it is necessary to continue operation, an adequate temporary solution should be adopted. This should be reported to the owner of the equipment so all parties are advised. Repair and maintenance of electrical components should include initial safety checks and component inspection procedures. If a fault exists and could compromise safety, no electrical supply should be connected to the circuit until it is satisfactorily dealt with. If the fault cannot be corrected immediately but it is necessary to continue operation, an adequate temporary solution should be adopted. This should be reported to the owner of the equipment so all parties are advised. Initial safety checks should include the following:

- The capacitors should be discharged in a safe manner to avoid sparking risks
- No live electrical components and wiring can be exposed during the system charging, recovery or purging. Earth bonding should be continuous
- Earth bonding should be continuous

1.5 Repair of Sealed Components

1. During repair of sealed components, all electrical supplies should be disconnected from the equipment being worked upon prior to any removal of sealed covers. If it is absolutely necessary to have an electrical supply connected with the equipment during servicing, a permanently operating form of leak detection should be located at the most critical point to warn of a potentially hazardous situation.
2. Particular attention should be paid to the following to ensure that, by working on electrical components, the casing is not altered in such a way that Protection is compromised. This should include damage to cables, an excessive number of connections, terminals not made as per original specifications, damage to seals, and incorrect fitting of glands.
 - Ensure that all apparatuses are mounted securely.
 - Ensure that seals or sealing materials have not degraded such that they can no longer prevent the ingress of flammable atmospheres. Parts for replacement should be in accordance with the manufacturer's specifications.
 - The use of silicon sealant may inhibit the effectiveness of some types of leak detection equipment. Intrinsically safe components do not have to be isolated prior to working on them.

1.6 Repair of Intrinsically Safe Components

Do not apply any permanent inductive or capacitance loads to the circuit without ensuring that such loads will not exceed the permissible voltage or current permitted for the equipment in use. Intrinsically safe components are the only types that can be worked on when the components live in a flammable atmosphere. The test apparatus should be provided with the correct rating. Replace components only with parts specified by the manufacturer. Other parts may result in the ignition of refrigerant in the atmosphere caused by a leak.

1.7 Transportation and Marking

Transport the equipment containing flammable refrigerants in accordance with the transport regulations. Mark the equipment with signs in compliance with local regulations.

1.8 Disposal

1.8.1 General

- Components and accessories of the unit are not ordinary domestic wastes.
- The unit, compressors, and motors, etc. can only be disposed of by qualified specialists.
- This unit uses hydrofluorocarbon that can only be disposed of by qualified specialists

1.8.2 Packaging

- Dispose of the packaging properly.
- Observe all relevant regulations



1.8.3 Refrigerant Removal, Evacuation, Charge, Recovery, and Unit Decommissioning

WARNING !

Due to the feature of the R290 refrigerant, only carry out work when you have specific expert refrigeration knowledge and are competent for handling R290 refrigerant.

Work on the refrigerant circuit with flammable refrigerant in safety group A3 may only be carried out by authorized heating contractors.

1.8.3.1 Removal and evacuation

When breaking into the refrigerant circuit for repair or any other purpose, follow the conventional procedures. However, it is important to follow the best practice since flammability should be considered. Operate as per the following procedure:

- Remove refrigerant;
- Purge the circuit with inert gas;
- Evacuate;
- Purge the circuit again with inert gas;
- Open the circuit by cutting or brazing

The refrigerant charged should be recovered and put in correct recovery cylinders. The system should be flushed with OFN to guarantee the unit safety. This process may need to be repeated several times. Compressed air or oxygen should not be used.

Flushing should be achieved by filling the system with OFN until the working pressure is achieved before venting to the atmosphere, and recovering the system to a vacuum. This process should be repeated until no refrigerant exists in the system. Upon the final OFN charge, the system should be vented down to reach the atmospheric pressure to start the work.

This operation is absolutely vital if brazing operations on the pipe-work are to take place.

Ensure that the outlet of the vacuum pump is not closed to any ignition sources and adequate ventilation is available.

1.8.3.2 Charging procedures

In addition to conventional charging procedures, the following requirements should be followed:

- Ensure that contamination of different refrigerants does not occur when charging equipment is used. Hoses or lines should be as short as possible to minimize the amount of refrigerant contained in them.
- Earth the refrigeration system prior to charging the system with refrigerant.
- Label the system upon completion of the charging (if the system has not been labeled).
- Extreme care should be taken not to overfill the refrigeration system.
- Prior to recharging the system, test it with OFN. The system should be leak tested upon completion of charging but prior to commissioning. Carry out a follow-up leak test before leaving the site.

1.8.3.3 Recovery

When removing refrigerant from the system, either for service or decommissioning, we recommend you remove all refrigerants safely by following the best practice.

When transferring refrigerant into cylinders, only use appropriate refrigerant recovery cylinders. Ensure that a proper number of cylinders are available for accommodating all the refrigerant. All cylinders to be used are designated and labeled for the recovered refrigerant (i.e., special cylinders for the recovery of refrigerant). The cylinders should be complete with pressure relief valves and associated shut-off valves that work properly.

Empty recovery cylinders should be evacuated and, if possible, cooled before the recovery starts.

The recovery equipment should work properly with a set of instructions concerning the equipment at hand, and should be suitable for the recovery of flammable refrigerants. In addition, a set of calibrated weighting scales should be available and

M thermal Nature Plus Series

work properly. Hoses should be complete with leak-free disconnection couplings and in good conditions. Before using the recovery equipment, check and verify that it works properly and has been properly maintained, and that any associated electrical components are sealed to prevent ignition in the event of a refrigerant leakage. Consult the manufacturer in case of any doubt.

The recovered refrigerant should be returned to the refrigerant supplier in correct recovery cylinders, with the relevant Waste Transfer Note arranged. Do not mix refrigerants in recovery units, especially in cylinders.

If compressors or compressor oils are to be removed, ensure that they have been evacuated to an acceptable level to ensure that flammable refrigerant does not remain within the lubricant. Carry out the evacuation process before returning the compressor to the suppliers. To accelerate this process, you can only heat the compressor body electrically. Safety drain oil from the system.

1.8.3.4 Decommissioning

Prior to this procedure, the technician should be completely familiar with the equipment and all its details. It is recommended that all refrigerants be recovered safely. Prior to the recovery, an oil and refrigerant sample should be taken for case analysis before re-use of reclaimed refrigerant. Electrical power should be available before the task is commenced.

1. Be familiar with the equipment and its operation.
2. Isolate the system electrically
3. Before attempting the procedure ensure that:
 - Mechanical handling equipment is available, if required, for handling refrigerant cylinders.
 - All personal protective equipment should be available and used securely.
 - The recovery process should be supervised at all time by a competent person.
 - Recovery equipment and cylinders should conform to the appropriate standards.
4. Pump down the refrigerant system, if possible.
5. If a vacuum is not possible, provide a manifold to remove the refrigerant from various parts of the system.
6. Ensure that the cylinders are situated on the scales before the recovery starts.
7. Start the recovery machine and operate it in accordance with the manufacturer's instructions.
8. Do not overfill the cylinders (for no more than 80% of the volume).
9. Do not exceed the maximum working pressure of the cylinders, even temporarily.
10. When the cylinders have been filled securely and the process is completed, immediately remove the cylinders and the equipment from the site and close all isolation valves on the equipment.
11. The recovered refrigerant should not be re-used in any other refrigeration system unless it has been cleaned and checked.

1.9 R290 System Service

When repairing systems that use R290 refrigerant, the following warnings and operating requirements should be noted.

1.9.1 Warning about the R290 refrigerant



The following information indicates a hazard with a medium level of risk which, if not avoided, could result in death or serious injury.

The following applies to R290 refrigerant systems.

Prior to beginning work on systems containing flammable refrigerants, safety checks are necessary to ensure that the risk of ignition is minimized.

For repair to the refrigerating system, the following precautions shall be complied with prior to conducting work on the system.

Work shall be undertaken under a controlled procedure so as to minimize the risk of a flammable gas or vapour being present while the work is being performed.

All maintenance staff and others working in the local area shall be instructed on the nature of work being carried out. Work in confined spaces shall be avoided. The area around the workspace shall be sectioned off. Ensure that the conditions within the area have been made safe by control of flammable material.

The area shall be checked with an appropriate refrigerant detector prior to and during work, to ensure the technician is aware of potentially flammable atmospheres.

Ensure that the leak detection equipment being used is suitable for use with flammable refrigerants, i.e. non-sparking, adequately sealed or intrinsically safe.

If any hot work is to be conducted on the refrigeration equipment or any associated parts, appropriate fire extinguishing equipment shall be available to hand. Have a dry powder or CO₂ fire extinguisher adjacent to the charging area.

No person carrying out work in relation to a refrigeration system which involves exposing any pipe work that contains or has contained flammable refrigerant shall use any sources of ignition in such a manner that it may lead to the risk of fire or explosion.

All possible ignition sources, including cigarette smoking, should be kept sufficiently far away from the site of installation, repairing, removing and disposal, during which flammable refrigerant can possibly be released to the surrounding space.

Prior to work taking place, the area around the equipment is to be surveyed to make sure that there are no flammable hazards or ignition risks. "No Smoking" signs shall be displayed.

Ensure that the area is in the open or that it is adequately ventilated before breaking into the system or conducting any hot work. A degree of ventilation shall continue during the period that the work is carried out. The ventilation should safely disperse any released refrigerant and preferably expel it externally into the atmosphere.

Where electrical components are being changed, they shall be fit for the purpose and to the correct specification. At all times the manufacturer's maintenance and service guidelines shall be followed. If in doubt consult the manufacturer's technical department for assistance.

The following checks shall be applied to installations using flammable refrigerants:

- the charge size is in accordance with the room size within which the refrigerant containing parts are installed;
- the ventilation machinery and outlets are operating adequately and are not obstructed;

M thermal Nature Plus Series

- if an indirect refrigerating circuit is being used, the secondary circuit shall be checked for the presence of refrigerant;
- marking to the equipment continues to be visible and legible. Markings and signs that are illegible shall be corrected;
- refrigeration pipe or components are installed in a position where they are unlikely to be exposed to any substance which may corrode refrigerant containing components, unless the components are constructed of materials which are inherently resistant to being corroded or are suitably protected against being so corroded.

Repair and maintenance to electrical components shall include initial safety checks and component inspection procedures.

If a fault exists that could compromise safety, then no electrical supply shall be connected to the circuit until it is satisfactorily dealt with. If the fault cannot be corrected immediately but it is necessary to continue operation, an adequate temporary solution shall be used. This shall be reported to the owner of the equipment so all parties are advised.

Initial safety checks shall include:

- that capacitors are discharged: this shall be done in a safe manner to avoid possibility of sparking;
- that no live electrical components and wiring are exposed while charging, recovering or purging the system;
- that there is continuity of earth bonding.

During repairs to sealed components, all electrical supplies shall be disconnected from the equipment being worked upon prior to any removal of sealed covers, etc. If it is absolutely necessary to have an electrical supply to equipment during servicing, then a permanently operating form of leak detection shall be located at the most critical point to warn of a potentially hazardous situation.

Particular attention shall be paid to the following to ensure that by working on electrical components, the casing is not altered in such a way that the level of protection is affected. This shall include damage to cables, excessive number of connections, terminals not made to original specification, damage to seals, incorrect fitting of glands, etc.

Ensure that seals or sealing materials have not degraded such that they no longer serve the purpose of preventing the ingress of flammable atmospheres.

Replacement parts shall be in accordance with the manufacturer's specifications.

Do not apply any permanent inductive or capacitance loads to the circuit without ensuring that this will not exceed the permissible voltage and current permitted for the equipment in use.

Intrinsically safe components are the only types that can be worked on while live in the presence of a flammable atmosphere. The test apparatus shall be at the correct rating.

Replace components only with parts specified by the manufacturer. Other parts may result in the ignition of refrigerant in the atmosphere from a leak.

Check that cabling will not be subject to wear, corrosion, excessive pressure, vibration, sharp edges or any other adverse environmental effects. The check shall also take into account the effects of ageing or continual vibration from sources such as compressors or fans.

When breaking into the refrigerant circuit to make repairs – or for any other purpose – conventional procedures shall be used. However, it is important that best practice is followed.

Since flammability is a consideration. The following procedure shall be adhered to:

- remove refrigerant;
- purge the circuit with inert gas;
- evacuate;
- purge again with inert gas;
- open the circuit by cutting or brazing.

The refrigerant charge shall be recovered into the correct recovery cylinders. The system shall be "flushed" with OFN to

render the unit safe. This process may need to be repeated several times. Compressed air or oxygen shall not be used for this task.

Flushing shall be achieved by breaking the vacuum in the system with OFN and continuing to fill until the working pressure is achieved, then venting to atmosphere, and finally pulling down to a vacuum.

This process shall be repeated until no refrigerant is within the system. When the final OFN charge is used, the system shall be vented down to atmospheric pressure to enable work to take place.

This operation is absolutely vital if brazing operations on the pipe-work are to take place.

Ensure that the outlet for the vacuum pump is not close to any ignition sources and there is ventilation available. Ensure that contamination of different refrigerants does not occur when using charging equipment. Hoses or lines shall be as short as possible to minimize the amount of refrigerant contained in them. Prior to recharging the system it shall be pressure tested with OFN.

DD.12 Decommissioning:

Before carrying out this procedure, it is essential that the technician is completely familiar with the equipment and all its detail. It is recommended good practice that all refrigerants are recovered safely. Prior to the task being carried out, an oil and refrigerant sample shall be taken in case analysis is required prior to re-use of reclaimed refrigerant. It is essential that electrical power is available before the task is commenced.

- a) Become familiar with the equipment and its operation.
- b) Isolate system electrically.
- c) Before attempting the procedure ensure that:
 - mechanical handling equipment is available, if required, for handling refrigerant cylinders;
 - all personal protective equipment is available and being used correctly;
 - the recovery process is supervised at all times by a competent person;
 - recovery equipment and cylinders conform to the appropriate standards.
- d) Pump down refrigerant system, if possible.
- e) If a vacuum is not possible, make a manifold so that refrigerant can be removed from various parts of the system.
- f) Make sure that cylinder is situated on the scales before recovery takes place.
- g) Start the recovery machine and operate in accordance with manufacturer's instructions.
- h) Do not overfill cylinders. (No more than 80 % volume liquid charge).
- i) Do not exceed the maximum working pressure of the cylinder, even temporarily.
- j) When the cylinders have been filled correctly and the process completed, make sure that the cylinders and the equipment are removed from site promptly and all isolation valves on the equipment are closed off.
- k) Recovered refrigerant shall not be charged into another refrigeration system unless it has been cleaned and checked.

Equipment shall be labelled stating that it has been de-commissioned and emptied of refrigerant. The label shall be dated and signed. Ensure that there are labels on the equipment stating the equipment contains flammable refrigerant.

When removing refrigerant from a system, either for servicing or decommissioning, it is recommended good practice that all refrigerants are removed safely.

When transferring refrigerant into cylinders, ensure that only appropriate refrigerant recovery cylinders are employed. Ensure that the correct number of cylinders for holding the total system charge are available. All cylinders to be used are designated for the recovered refrigerant and labelled for that refrigerant (i.e. special cylinders for the recovery of refrigerant). Cylinders shall be complete with pressure relief valve and associated shut-off valves in good working order. Empty recovery cylinders are evacuated and, if possible, cooled before recovery occurs.

The recovery equipment shall be in good working order with a set of instructions concerning the equipment that is at hand and shall be suitable for the recovery of flammable refrigerants. In addition, a set of calibrated weighing scales shall be available and in good working order. Hoses shall be complete with leak-free disconnect couplings and in good condition.

M thermal Nature Plus Series

Before using the recovery machine, check that it is in satisfactory working order, has been properly maintained and that any associated electrical components are sealed to prevent ignition in the event of a refrigerant release. Consult manufacturer if in doubt.

The recovered refrigerant shall be returned to the refrigerant supplier in the correct recovery cylinder, and the relevant Waste Transfer Note arranged. Do not mix refrigerants in recovery units and especially not in cylinders.

If compressors or compressor oils are to be removed, ensure that they have been evacuated to an acceptable level to make certain that flammable refrigerant does not remain within the lubricant. The evacuation process shall be carried out prior to returning the compressor to the suppliers. Only electric heating to the compressor body shall be employed to accelerate this process. When oil is drained from a system, it shall be carried out safely.

Warning: disconnect the appliance from its power source during service and when replacing parts.

These units are partial unit air conditioners, complying with partial unit requirements of this International Standard, and must only be connected to other units that have been confirmed as complying to corresponding partial unit requirements of this International Standard.

1.9.2 Qualification requirements for maintenance personnel



The following information indicates a hazard with a high level of risk which, if not avoided, will result in death or serious injury.

These instructions are exclusively intended for qualified contractors and authorized installers

Work on the refrigerant circuit with flammable refrigerant in safety group A3 may only be carried out by authorized heating contractors. These heating contractors must be trained in accordance with EN 378 Part 4 or IEC 60335-2-40, Section HH. The certificate of competence from an industry accredited body.

Brazing/soldering work on the refrigerant circuit may only be carried out by contractors certified in accordance with ISO 13585 and AD 2000, Datasheet HP 100R. And only by contractors qualified and certified for the processes to be carried out. The work must fall within the range of applications purchased and be carried out in accordance with the prescribed procedures. Soldering/brazing work on accumulator connections requires certification of personnel and processes by a notified body according to the Pressure Equipment Directive (2014/68/EU).

Work on electrical equipment may only be carried out by a qualified electrician.

Before initial commissioning, all safety relevant points must be checked by the particular certified heating contractors. The system must be commissioned by the system installer or a qualified person authorized by the installer.

2 Electric wiring diagram

1Ph 8-16kW

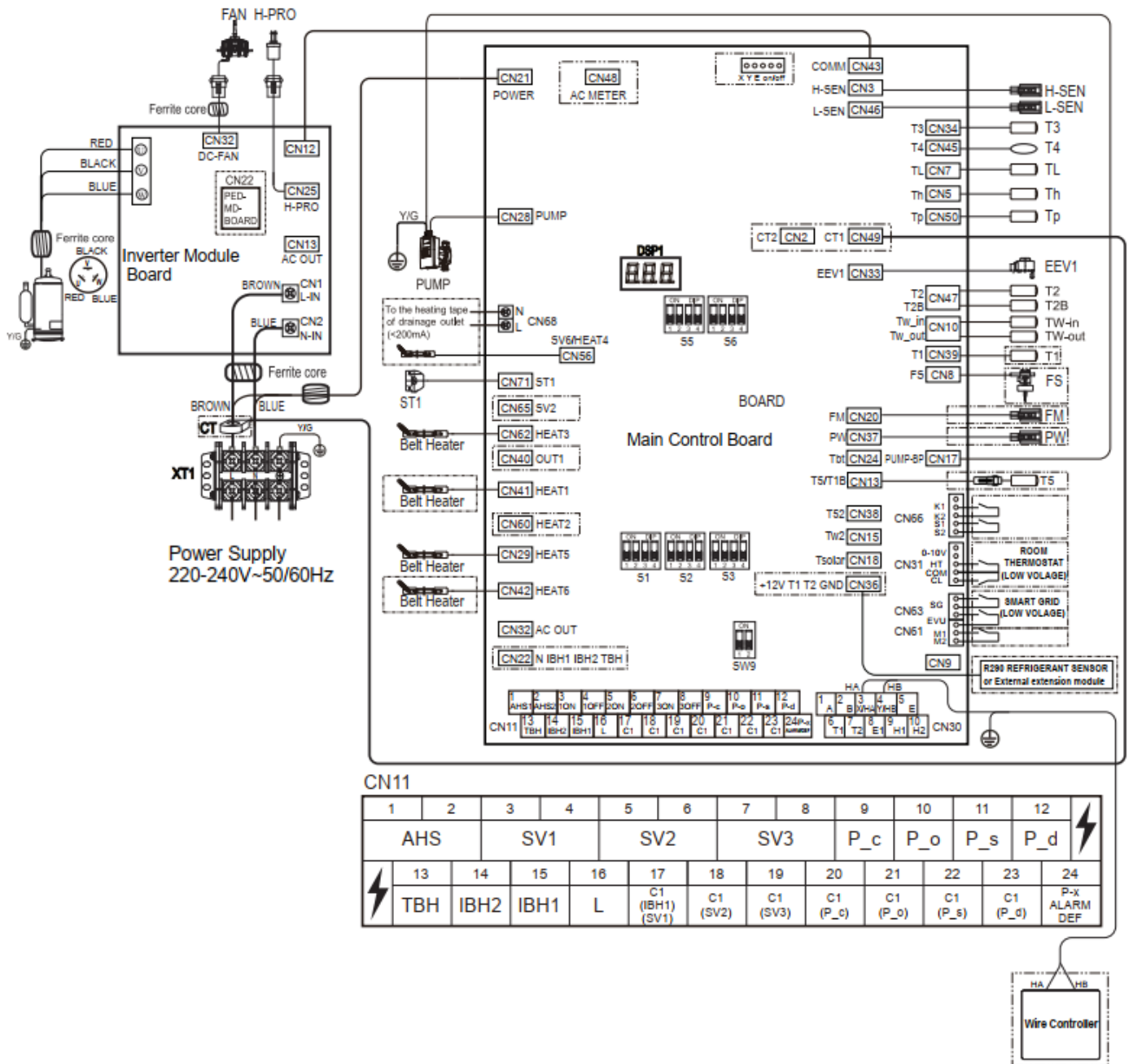
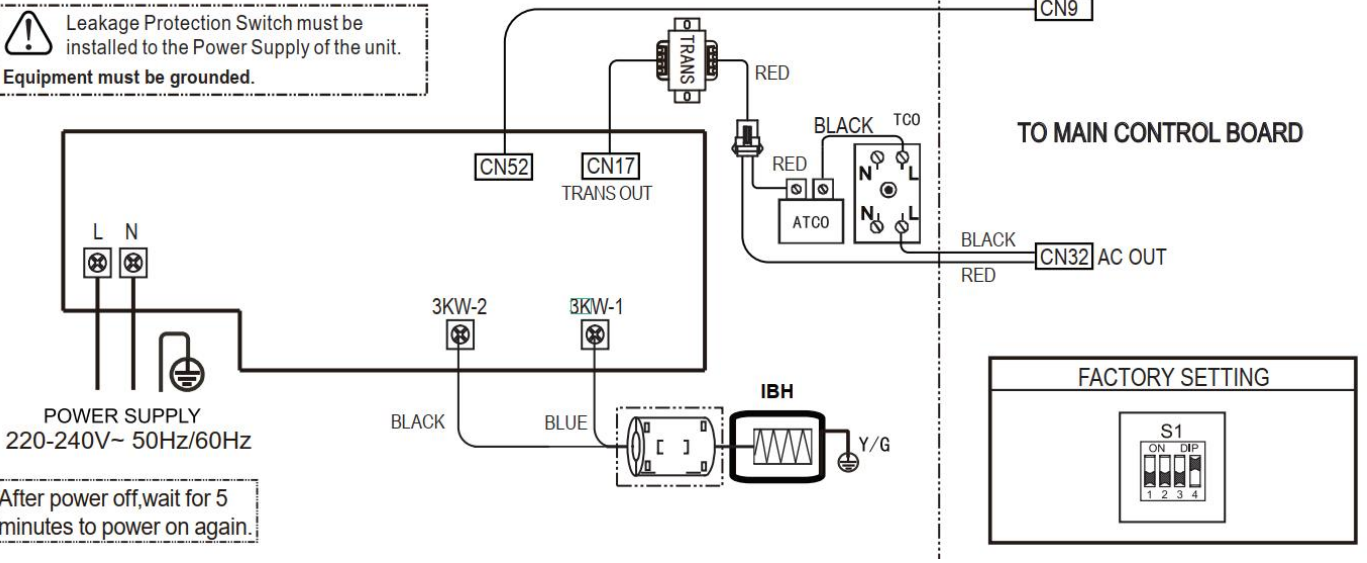

Figure2: 3kW IBH(One step control)

⚠ Leakage Protection Switch must be installed to the Power Supply of the unit.
Equipment must be grounded.



After power off, wait for 5 minutes to power on again.

Figure1: 9kW IBH(Three step control)

⚠ Leakage Protection Switch must be installed to the Power Supply of the unit.
Equipment must be grounded.

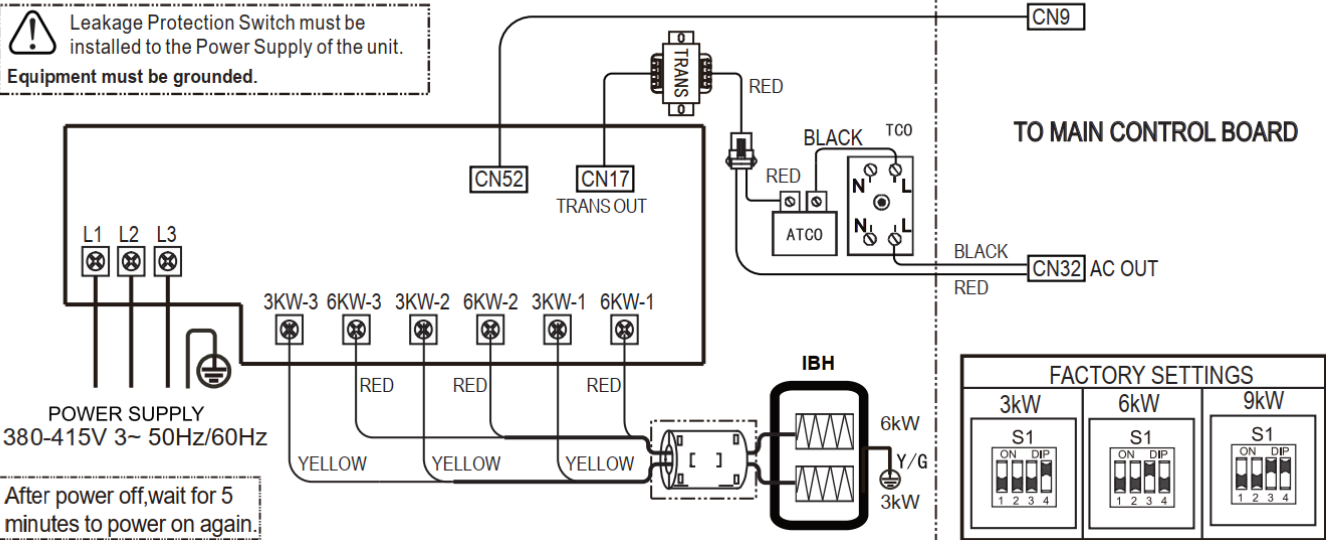

After power off, wait for 5 minutes to power on again.

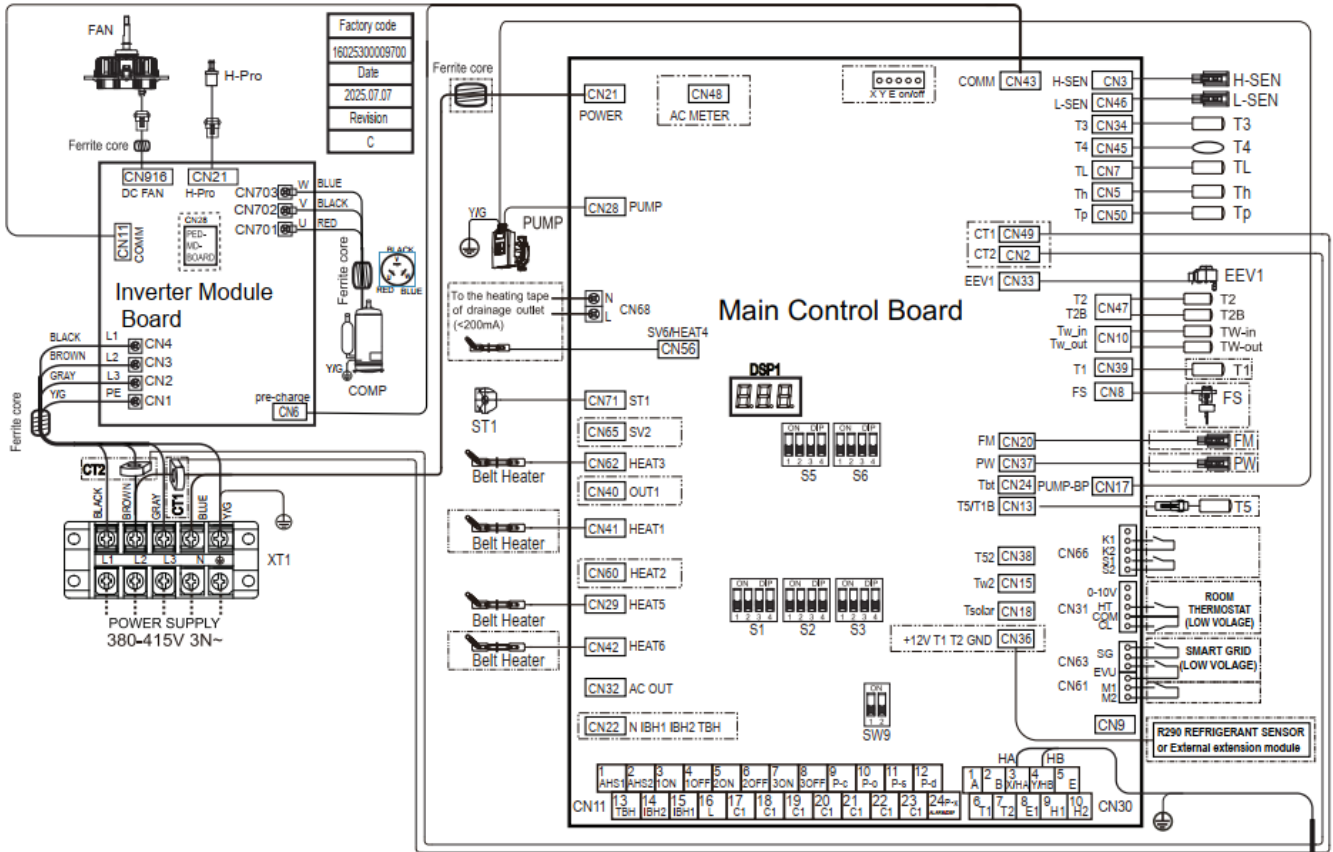

CN11

1	2	3	4	5	6	7	8	9	10	11	12	
AHS		SV1		SV2		SV3		P_c	P_o	P_s	P_d	⚡
⚡	13	14	15	16	17	18	19	20	21	22	23	24
	TBH	IBH2	IBH1	L	C1 (IBH1) (SV1)	C1 (SV2)	C1 (SV3)	C1 (P_c)	C1 (P_o)	C1 (P_s)	C1 (P_d)	P-x ALARM DEF

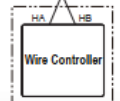

Figure2: 3kW IBH(One step control)

⚠ Leakage Protection Switch must be installed to the Power Supply of the unit.
Equipment must be grounded.

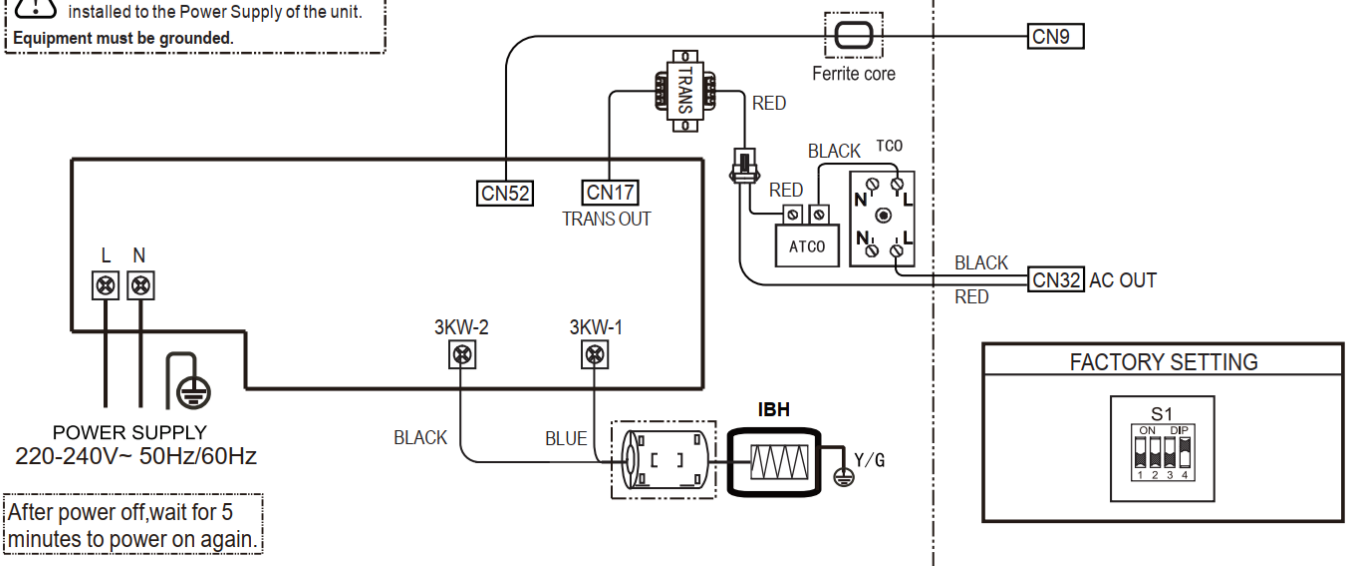
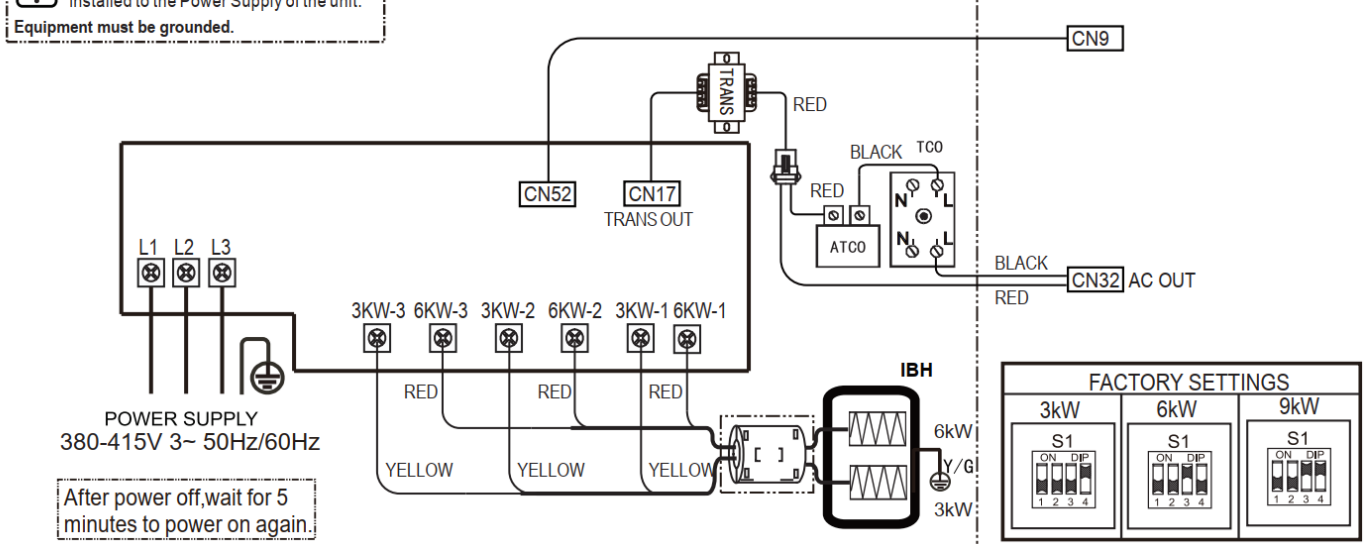
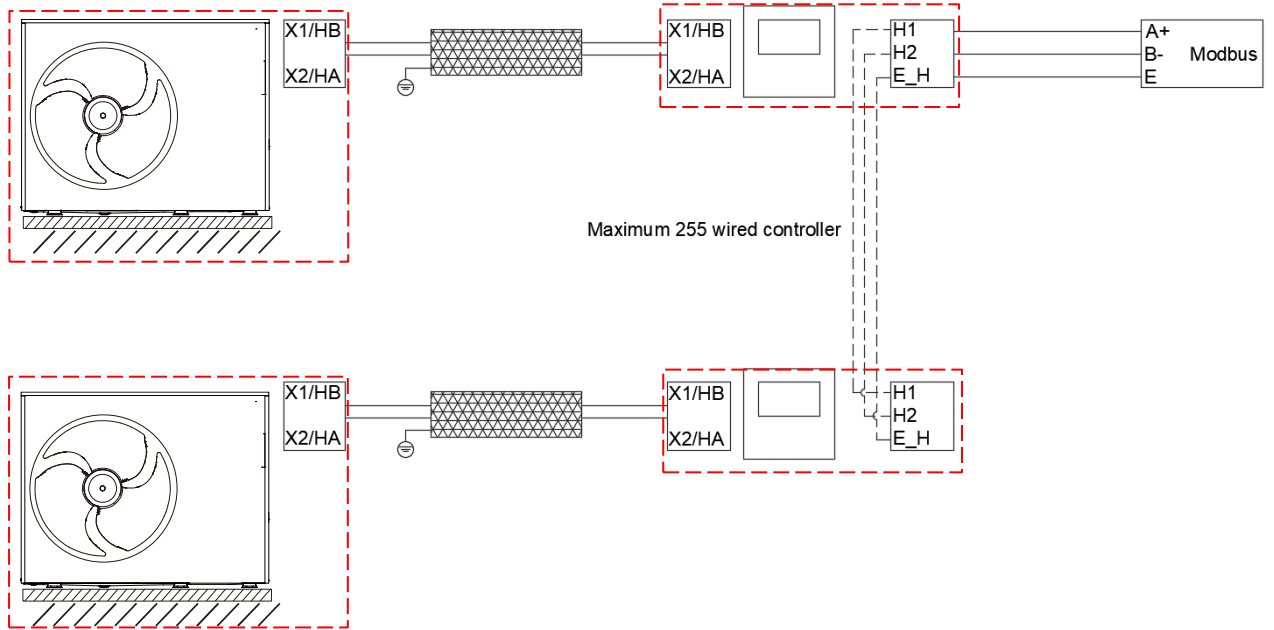

Figure1: 9kW IBH(Three step control)

⚠ Leakage Protection Switch must be installed to the Power Supply of the unit.
Equipment must be grounded.



BMS application



3 Electric Control Box Layout

1Ph 8-10kW

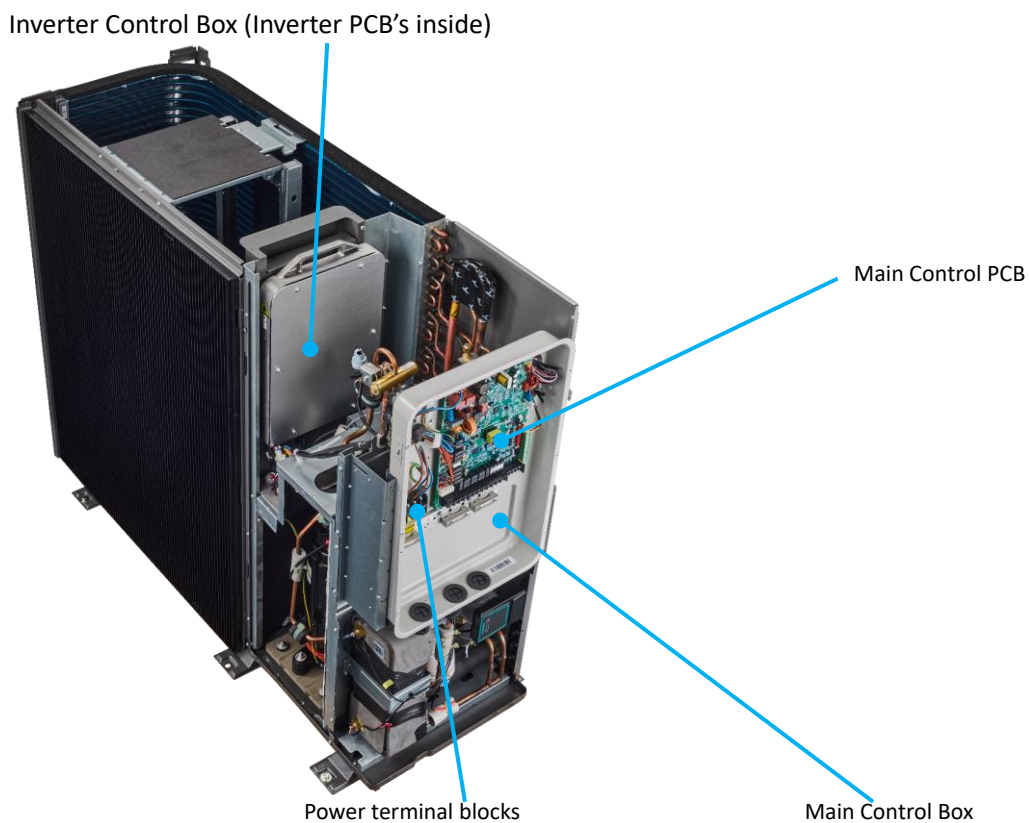

3Ph 8-10kW

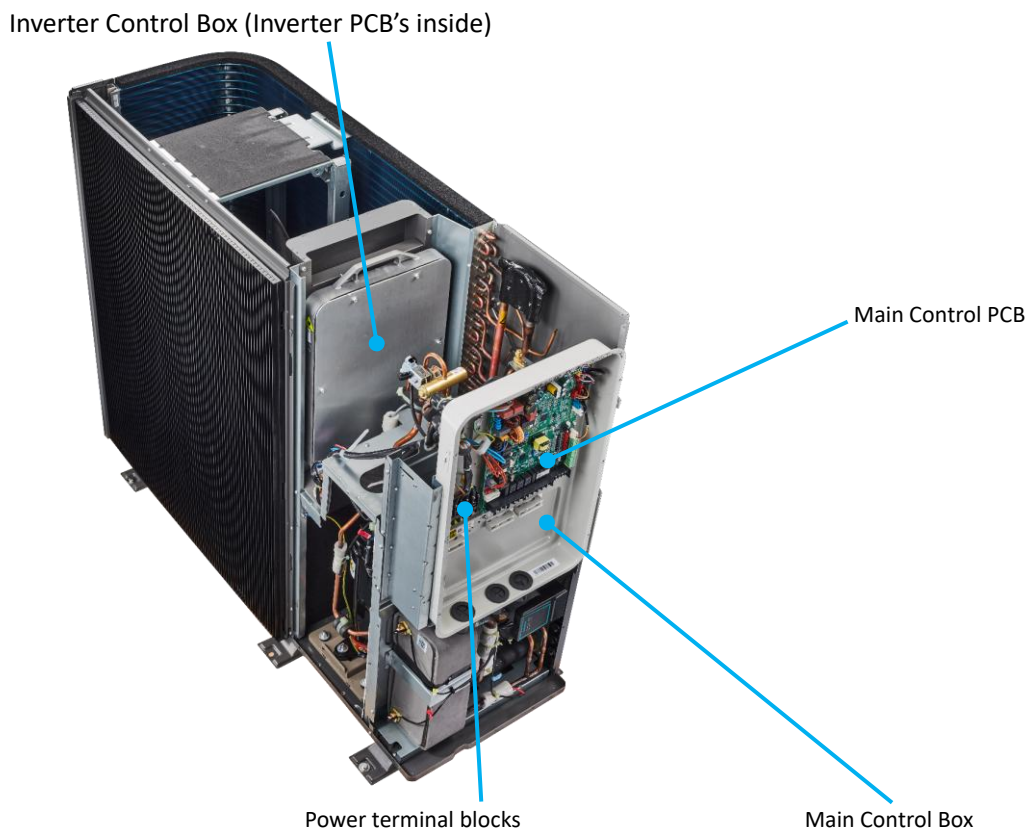

1Ph 12-16kW

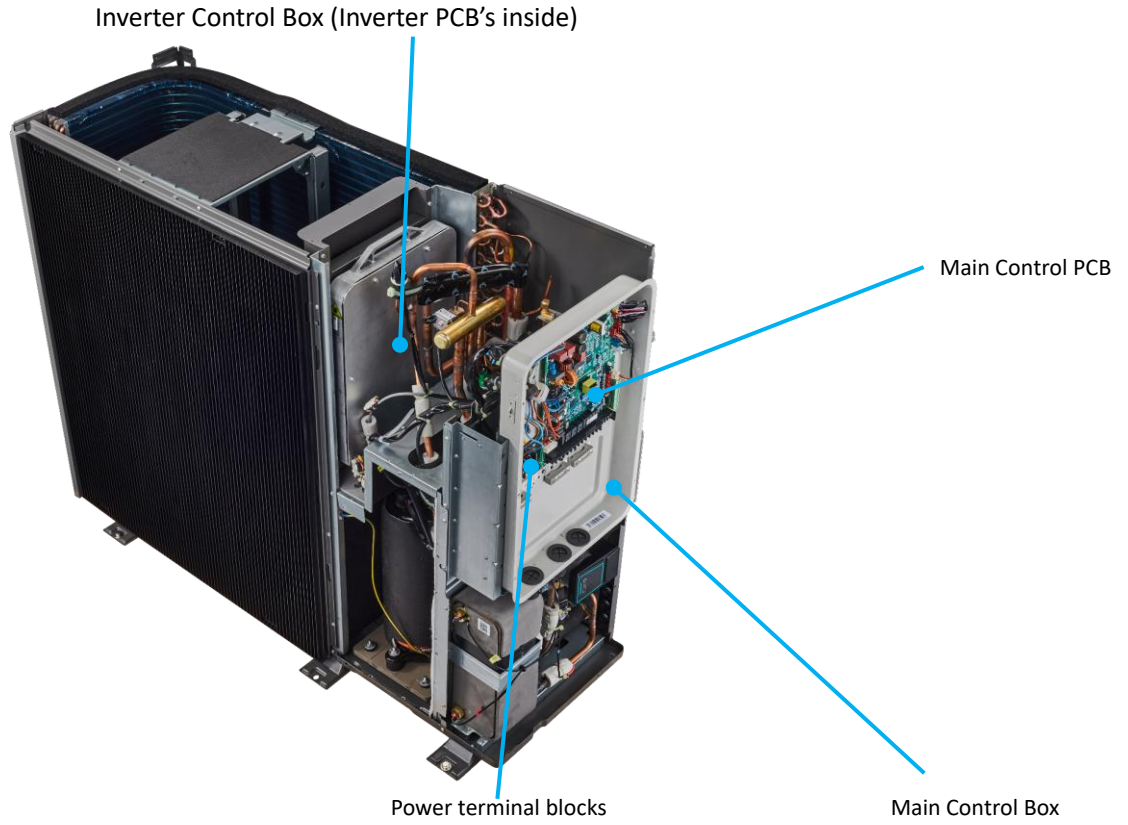

3Ph 12-16kW

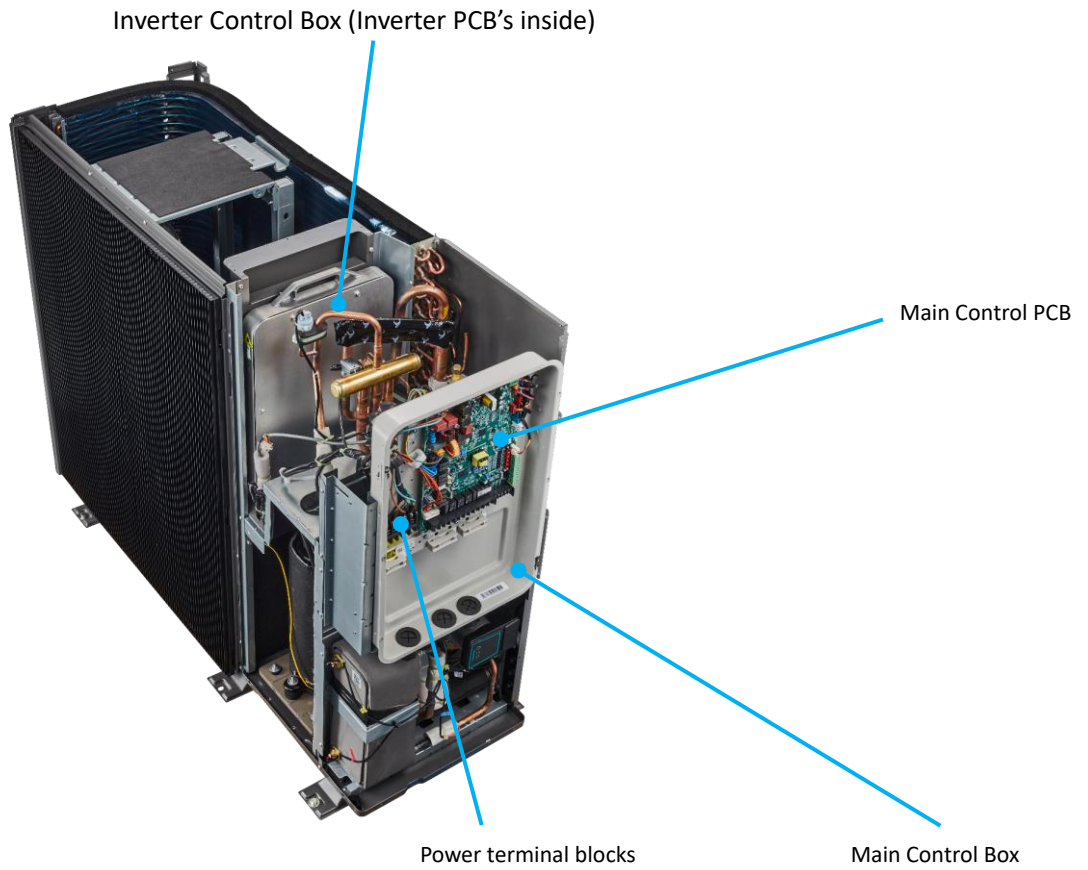

Note:

1. For maintenance, the unit has retrofitted its structure for better after-service experience.



Without removing the top cover, the aftersales personnel can maintain and troubleshoot the unit by just removing the right-side panel.

2. Main Control PCB consists of Refrigerant system and hydronic system, which is sealed in the hermetic electric control box and placed vertically for safety consideration.
3. The hermetic electric control box of inverter PCB is available to be took out entirely. If there's something wrong with inverter PCB, it's suggested to unscrew the cover to Determine possible inverter PCB failure (Refer to part 4 Appendix: Guide for identifying inverter PCB failure) and replace the whole inverter control box entirely.

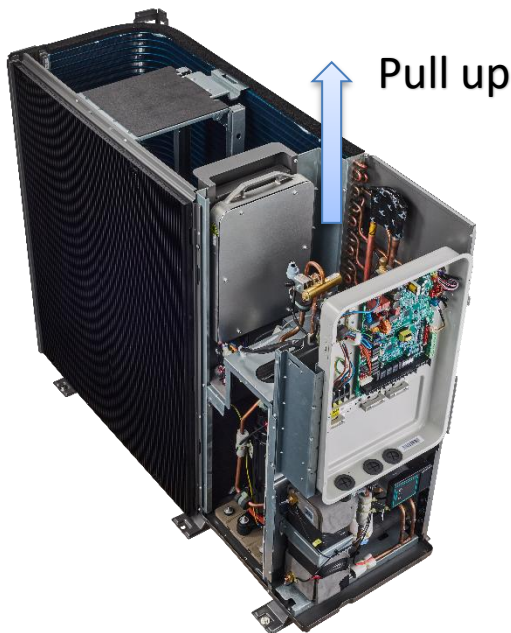

This electric control box is consists of inverter PCB and metal box with air cooling heatsink design and thermally conductive silicone encapsulant, which makes it integrated for better thermal and reliable performance.

*The photos on the left are for illustration only.

4 Outdoor Unit PCBs

4.1 Main Control PCB

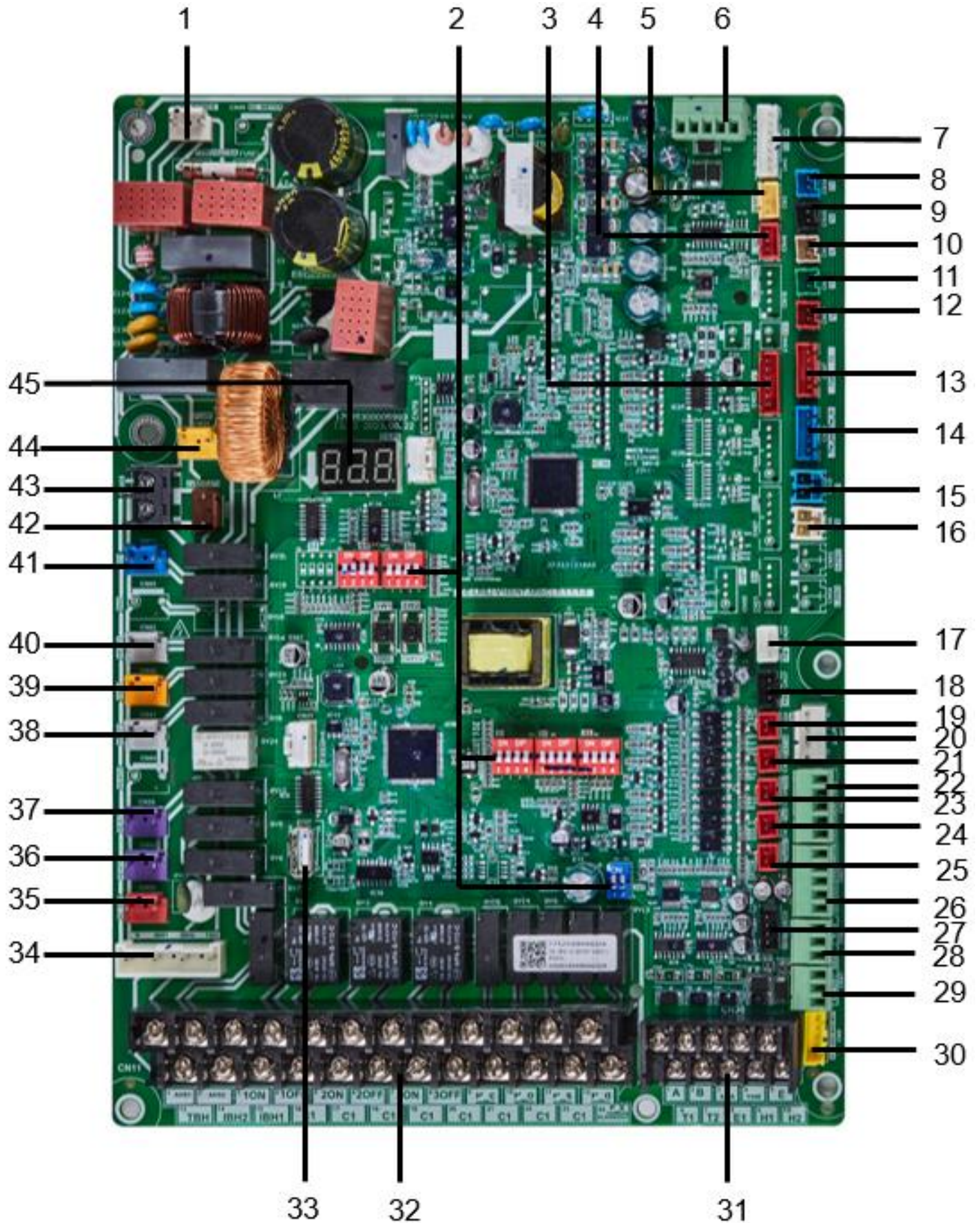

Label	Port	Code	Content	Rated Voltage
1	CN21	POWER	Port for power supply	230VAC
2	S1, S2, S3, S5, S6, SW9	/	Dip switch	/
3	CN33	EEV1	Port for electrical expansion valve1	0-12V DC
4	CN3	H-SEN	Port for high-pressure sensor	0-5V DC
5	CN46	L-SEN	Port for low-pressure sensor	0-5V DC
6	CN35	RS485 ; on/off	Reserved	0-5V DC
7	CN43	COMM	Port for communication with Inverter PCB	0-5V DC
8	CN34	T3	Port for T3 temp. sensor	0-3.3V DC
9	CN45	T4	Port for T4 temp. sensor	0-3.3V DC
10	CN7	TL	Port for TL temp. sensor	0-3.3V DC
11	CN5	Th	Port for Th temp. sensor	0-3.3V DC
12	CN50	Tp	Port for Tp temp. sensor	0-3.3V DC
13	CN47	T2 T2B	Port for T2, T2B temp. sensor	0-5V DC
14	CN10	Tw_in ; Tw_out	Port for Tw_in, Tw_out temp. sensor	0-5V DC
15	CN39	T1	Port for T1 temp. sensor	0-5V DC
16	CN8	FS	Port for flow switch	0-12V DC
17	CN20	FM	Port for sensor of water flow	0-5V DC
18	CN37	PW	Port for sensor of water pressure	0-5V DC
19	CN24	Tbt	Port for Tbt temp. sensor	0-5V DC
20	CN17	PUMP_BP	Port for internal pump	0-5V DC
21	CN13	T5/T1B	Port for T5/T1B temp. sensor	0-5V DC
22	CN66	K1 K2 S1 S2	Reserved	0-5V DC
23	CN38	T52	Port for T52 temp. sensor	0-5V DC
24	CN15	Tw2	Port for Tw2 temp. sensor	0-5V DC
25	CN18	Tsolar	Port for Tsolar temp. sensor	0-5V DC
26	CN31	0-10V ; HT ; COM ; CL	(0-10V) - Output port for 0-10V (HT) - Control port for room thermostat (heating mode) (COM) - Power port for room thermostat (CL) - Control port for room thermostat (cooling mode)	0-12V DC To dry contact signal
27	CN36	+12V T1 T2 GND	Port for refrigerant sensor	0-12V DC
28	CN63	SG EVU	(SG) - Port for smart grid (photovoltaic signal) (EVU) - Port for smart grid (grid signal)	0-12V DC To dry contact signal
29	CN61	M1 M2	Port for remote switch	0-12V DC To dry contact signal
30	CN9	NOP GND IBH2 IBH1	Control port for internal backup heater1/2	0-5V DC
31	CN30	A B X/HA Y/HB E T1 T2 E1 H1 H2	(Port, 3, 4) - Port for communication with the User Interface (Port 6.7) - Port for thermostat transfer board (Port 8, 9, 10) - Port for Internal machine Parallel	AB:12VDC X/HA Y/HB:18VDC T1 T2 E1 H1 H2: 0-5VDC

Label	Port	Code	Content	Rated Voltage
32	CN11	/	(Port1, 2) - Additional heat source (Port3, 4) - Port for SV1(3-way valve) (Port5, 6) - Port for SV2(3-way valve) (Port7, 8) - Port for SV3(3-way valve) (Port9, 10, 11, 12) - Port for zone 2 pump(P_c)/ zone 1 pump(P_o)/ solar energy pump(P_s)/ pipe pump(P_d) (Port13) - Control port for tank booster heater (Port14) - Control port for internal backup heater 1 (Port15) - Control port for internal backup heater (Port24) - Reserved	230V AC
33	CN4	USB	Port for USB	/
34	CN22	N IBH1 BH2 TBH	Control port for backup heater/booster heater	230V AC
35	CN32	AC OUT	Port for transformer power input	230V AC
36	CN42	HEAT6	Port for anti-freeze electric heating tape of plate heat exchanger	230V AC
37	CN29	HEAT5	Port for anti-freeze electric heating tape of plate heat exchanger	230V AC
38	CN41	HEAT1	Reserved port for electric heating tape	230V AC
39	CN40	OUT1	Reserved	230V AC
40	CN62	HEAT3	Port for electrical heating tape of crankshaft	230V AC
41	CN71	ST1	Port for 4-way valve	230V AC
42	CN56	HEAT4	Port for the electrical heating tape of chassis	230V AC
43	CN68	/	Port for electrical heating tape of drainage pipeline	230V AC
44	CN28	PUMP	Port for inverter pump power input	/
45	DSP1	DSP1	Digital display On standby: 0 Normal operation: The current frequency of compressor Error or protection: Error or protection code	/

M thermal Nature Plus Series



DIP switch settings

DIP switch: ON=1 OFF=0		Description	Default factory setting
S1 	1	Reserved	OFF
	2	0= Integrated electric heater 1= External electric heater	OFF
	3/4	0/0= Without backup heater 0/1= With backup heater(One step control) 1/0= With backup heater(Two step control) 1/1= With backup heater(Three step control)	3: OFF 4: OFF
S2 	1/2	Reserved	1: OFF 2: OFF
	3/4	0/0= Variable speed pump 1 0/1= Variable speed pump 2 1/0= Fixed speed pump 1/1= Reserved	3: OFF 4: OFF
S3 	1/2/3	0/0/0= Address 0#(master unit) 1/0/0= Address 1#(slave unit) 0/1/0= Address 2#(slave unit) 0/0/1= Address 3#(slave unit) 1/1/0= Address 4#(slave unit) 1/0/1= Address 5#(slave unit) 0/1/1= Address 6#(slave unit) (Reserved) 1/1/1= Address 7#(slave unit) (Reserved)	1: OFF 2: OFF 3: OFF
	4	Reserved	OFF
S5 	1/2/3/4	1/0/0/0= M thermal Nature Other settings= Reserved	1: ON 2: OFF 3: OFF 4: OFF
S6 	1/2/3/4	0/0/1/1= 1-phase for 8kW unit 0/1/0/0= 1-phase for 10kW unit 0/1/0/1= 1-phase for 12kW unit 0/1/1/0= 1-phase for 14kW unit 0/1/1/1= 1-phase for 16kW unit 1/0/1/1= 3-phase for 8kW unit 1/1/0/0= 3-phase for 10kW unit 1/1/0/1= 3-phase for 12kW unit 1/1/1/0= 3-phase for 14kW unit 1/1/1/1= 3-phase for 16kW unit	Depends on units

4.2 Inverter PCB

Single Phase 8-10kW Inverter PCB

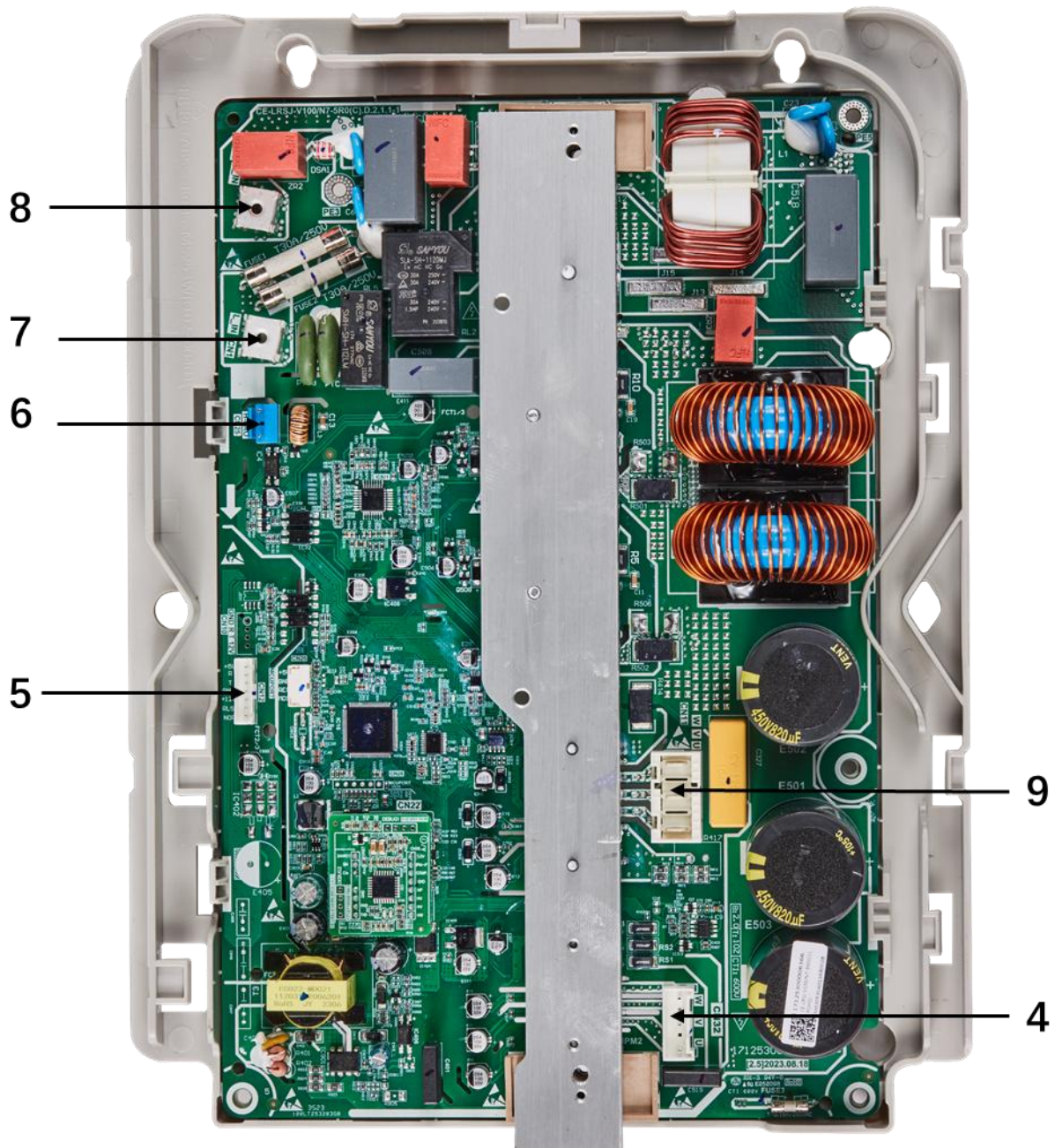

Label	Port	Code	Content	Voltage
4	CN32	/	DC fan power ports	Above 30V AC (varying according to frequency)
5	CN12	/	Port for communication with Main control board	0-12V DC
6	CN25	H-pro	Connect to high-pressure switch	0-5V DC(strong current)
7	CN1	L_IN	Power input L of inverter module	230V AC
8	CN2	N_IN	Power input N of inverter module	230V AC
9	CN11	/	Power output of inverter module to compressor	Above 90V AC (varying according to frequency)

M thermal Nature Plus Series

Single Phase 12-16kW Inverter PCB

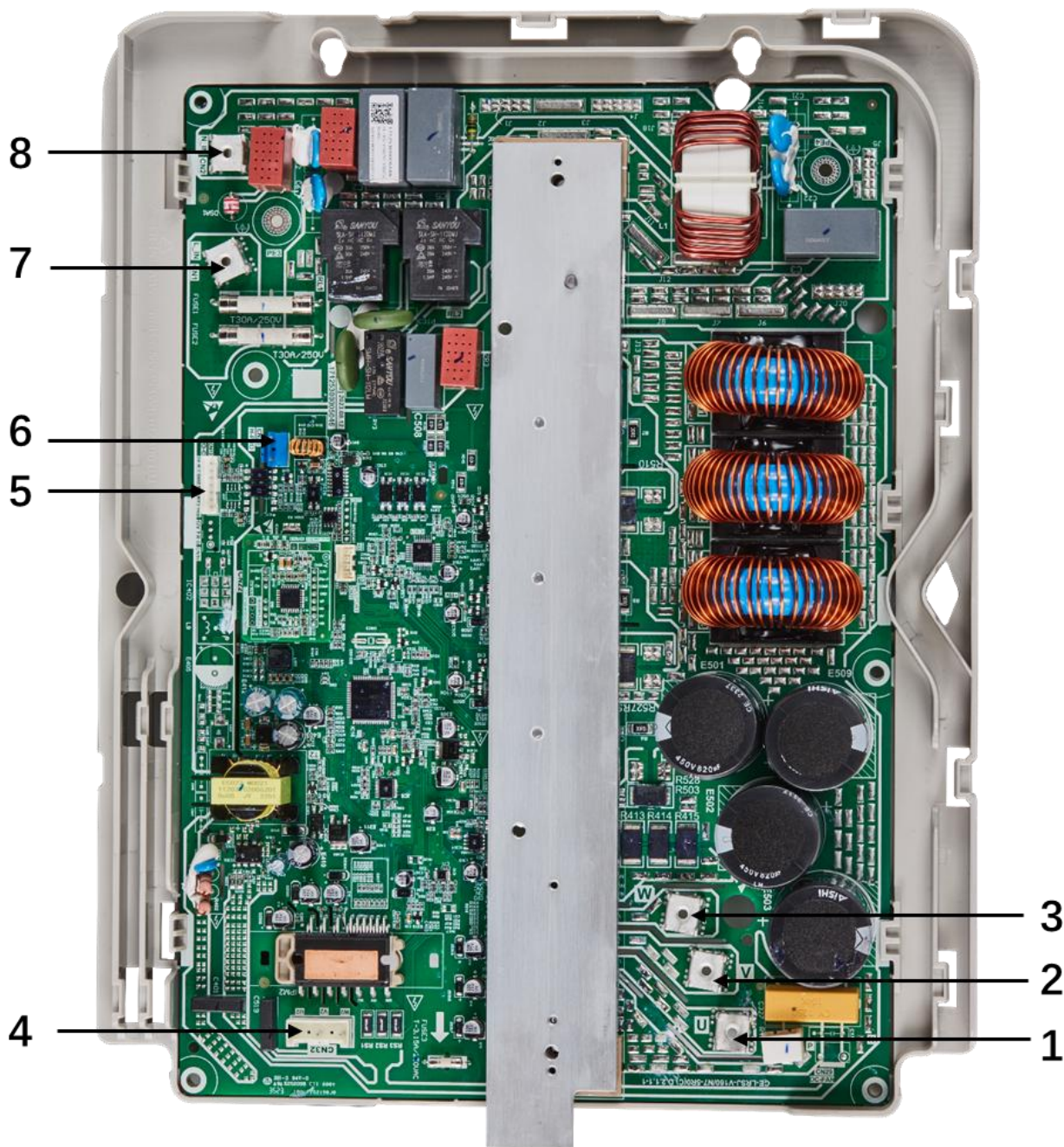

Label	Port	Code	Content	Voltage
1	U	U	Power output U of inverter module to compressor	Above 90V AC (varying according to frequency)
2	V	V	Power output V of inverter module to compressor	Above 90V AC (varying according to frequency)
3	W	W	Power output W of inverter module to compressor	Above 90V AC (varying according to frequency)
4	CN32	/	DC fan power ports	Above 30V AC (varying according to frequency)
5	CN12	/	Port for communication with Main control board	0-12V DC
6	CN25	H-pro	Connect to high-pressure switch	0-5V DC(strong current)
7	CN1	L_IN	Power input L of inverter module	230V AC
8	CN2	N_IN	Power input N of inverter module	230V AC

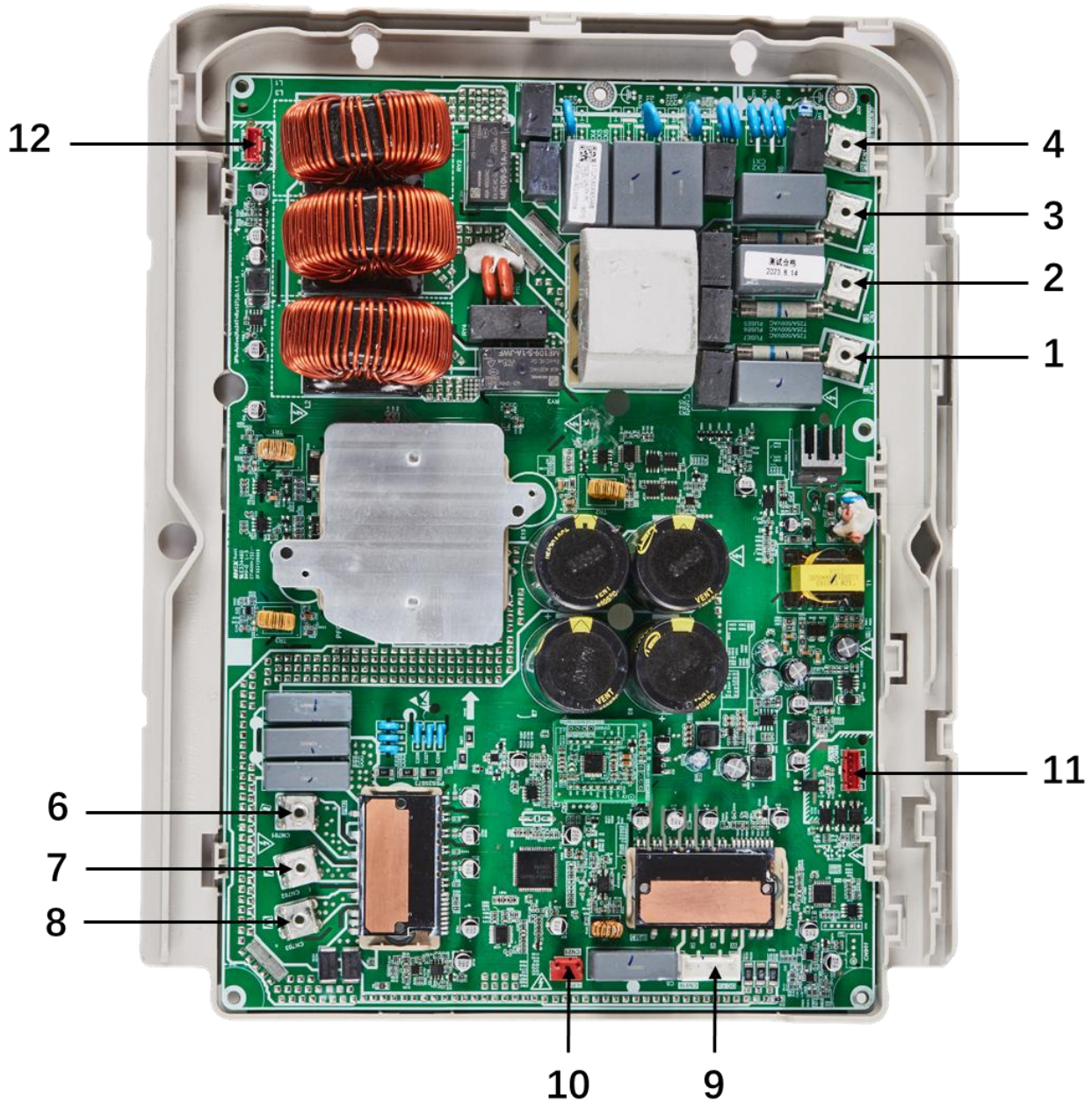

Label	Port	Code	Content	Voltage
1	CN4	L1	Power input L1 of inverter PCB	Phase to phase voltage 380VAC
2	CN3	L2	Power input L2 of inverter PCB	Phase to phase voltage 380VAC
3	CN2	L3	Power input L3 of inverter PCB	Phase to phase voltage 380VAC
4	CN1	PE	Earth	/
6	CN701	U	Power output U of inverter PCB to compressor	46-415VAC(varying according to frequency)
7	CN702	V	Power output V of inverter PCB to compressor	46-415VAC(varying according to frequency)
8	CN703	W	Power output W of inverter PCB to compressor	46-415VAC(varying according to frequency)
9	CN916	DCFAN	DC fan power ports	46-415VAC(varying according to frequency)
10	CN21	H-Pro	Connect to high-pressure switch	On: 0V; Off: 6V
11	CN11	COMM	Port for communication with Main Control PCB	0-5V DC
12	CN6	Pre-charge	Low-power dissipation relay control port	ON: 12V; OFF: 0V

4.3 IBH PCB

1Ph 3kW IBH PCB

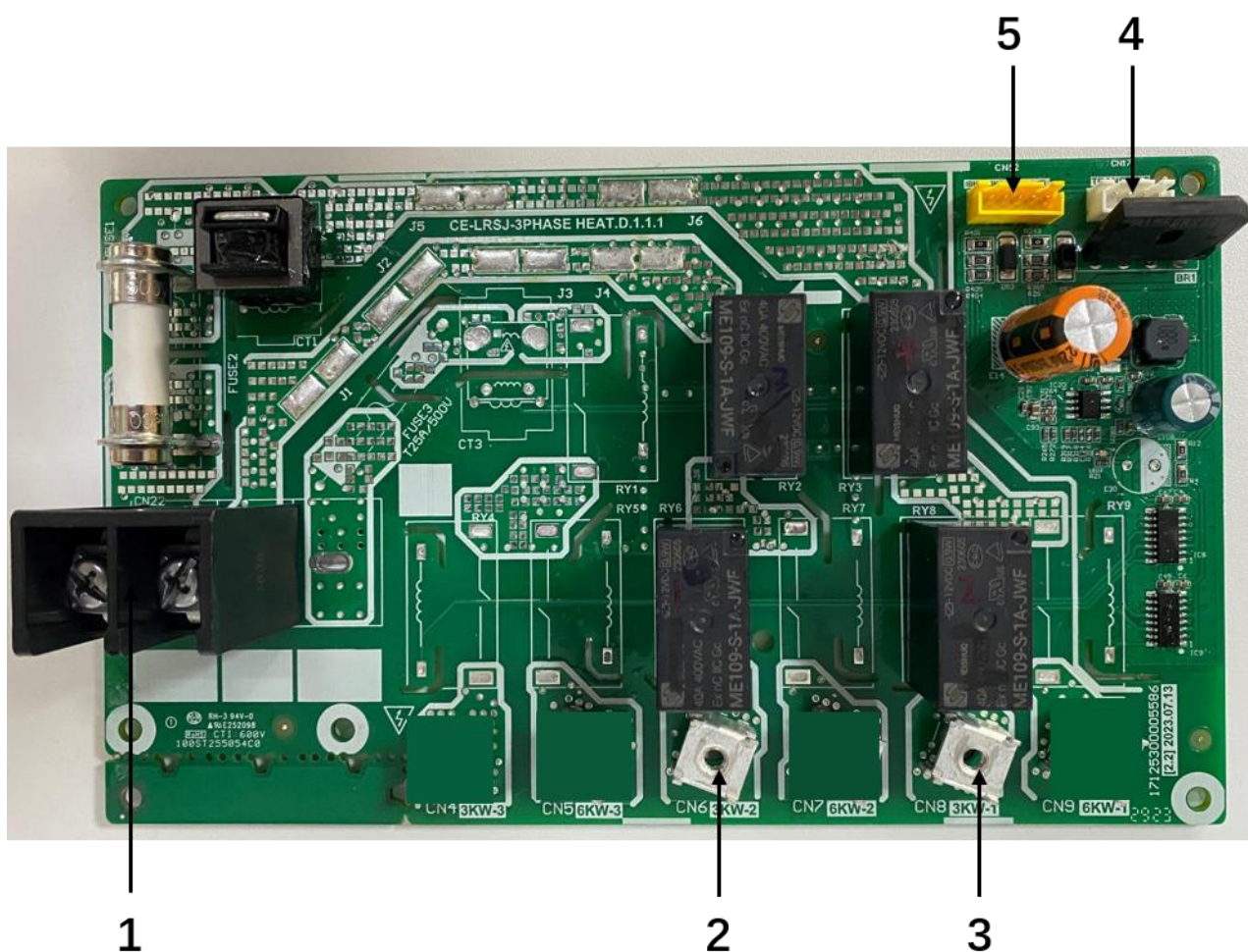

Label	Port	Code	Content	Voltage
1	CN22	L	Power input L of IBH PCB	Phase to phase voltage 230VAC
2	CN6	3KW-2	Power input N of 3KW IBH	Phase to phase voltage 230VAC
3	CN8	3KW-1	Power input L of 3KW IBH	Phase to phase voltage 230VAC
4	CN17	TRANS OUT	Transformer outputs to IBH	13.5VAC
5	CN52	IBH1 IBH2 GND IA IB	Main board and IBH control port	5VDC(varying);

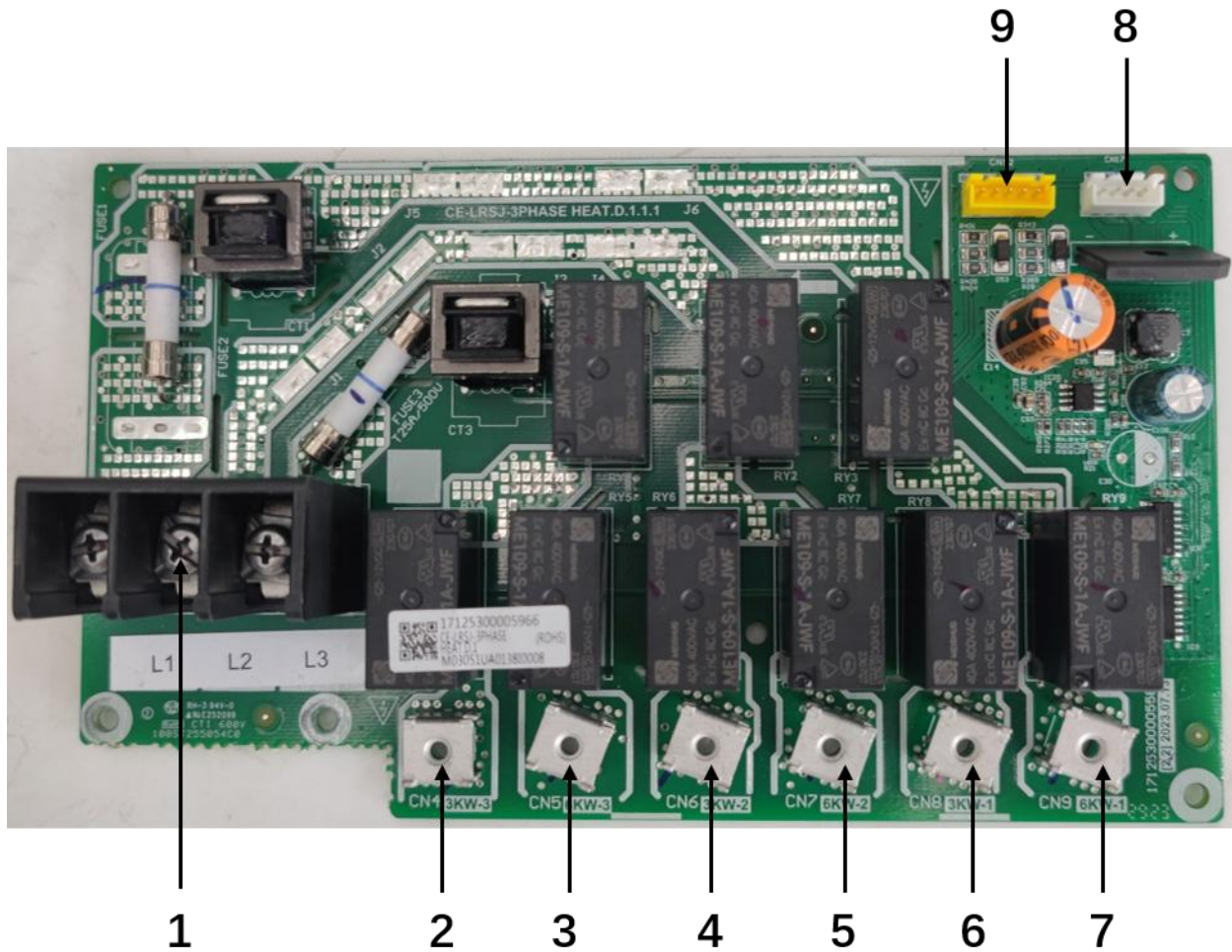

Label	Port	Code	Content	Voltage
1	CN22	L1 L2 L3	Power input L1/L2/L3 of IBH PCB	Phase to phase voltage 380VAC
2	CN4	3KW-3	Power input L3 of 3KW IBH	Phase to phase voltage 380VAC
3	CN5	6KW-3	Power input L3 of 6KW IBH	Phase to phase voltage 380VAC
4	CN6	3KW-2	Power input L2 of 3KW IBH	Phase to phase voltage 380VAC
5	CN7	6KW-2	Power input L2 of 6KW IBH	Phase to phase voltage 380VAC
6	CN8	3KW-1	Power input L1 of 3KW IBH	Phase to phase voltage 380VAC
7	CN9	6KW-1	Power input L1 of 6KW IBH	Phase to phase voltage 380VAC
8	CN17	TRANS OUT	Transformer outputs to IBH	13.5VAC
9	CN52	IBH1 IBH2 GND IA IB	Main board to IBH board control port	5VDC(varying);

5 Error Code Table

Water circuit error			
Error code	Description	Displayed on	
E0	water flow failure (10 times of E8)	User Interface and Main Control PCB	
E8	water flow protection	User Interface and Main Control PCB	
Communication error			
Error code	Description	Displayed on	
E2	Communication fault between User Interface and Main Control PCB	User Interface and Main Control PCB	
H0	Communication error of Main Control PCB	User Interface and Main Control PCB	
H1	Communication error between Main Control PCB and inverter PCB	User Interface and Main Control PCB	
Hd	Communication fault between master unit and slave unit.	User Interface and Main Control PCB	
Sensor error			
Error code	Description	Displayed on	
E3	T1 Electric Heater/AHS water outlet temperature sensor error	User Interface and Main Control PCB	
E4	T5 Water tank temperature sensor error	User Interface and Main Control PCB	
E5	T3 Outdoor unit heat exchanger bottom temperature sensor error	User Interface and Main Control PCB	
E6	T4 Ambient temperature sensor error	User Interface and Main Control PCB	
E7	Tbt Balance tank temperature sensor/ Final outlet water temperature of cascade system sensor error	User Interface and Main Control PCB	
E9	Th Return-air temperature sensor error	User Interface and Main Control PCB	
EA	Tp Discharge temperature sensor error	User Interface and Main Control PCB	
Eb	Tsolar Solar panel temperature sensor error	User Interface and Main Control PCB	
EC	T5_2 Water tank temperature sensor error (Reserved)	User Interface and Main Control PCB	
Ed	Tw_in Plate heat exchanger inlet water temperature sensor error	User Interface and Main Control PCB	
FC1	TL Outdoor unit heat exchanger outlet temperature sensor error	User Interface and Main Control PCB	
H2	T2 Plate heat exchanger outlet refrigerant temperature sensor error	User Interface and Main Control PCB	
H3	T2B Plate heat exchanger inlet refrigerant temperature sensor error	User Interface and Main Control PCB	
H5	Ta room temperature sensor error	User Interface and Main Control PCB	
H8	H-SEN High-pressure sensor error	User Interface and Main Control PCB	
H9	Tw2 Zone 2 water flow temperature sensor error	User Interface and Main Control PCB	
HA	Tw_out Plate heat exchanger outlet water temperature sensor error	User Interface and Main Control PCB	
P21	L-SEN Low-pressure sensor error	User Interface and Main Control PCB	
P27	H-SEN and L-SEN connected reversely (Detect when compressor is off)	User Interface and Main Control PCB	

Voltage error			
Error code	Description	Displayed on	
E1	Phase loss or phase reversal	User Interface and Main Control PCB	For 3Ph units
H7	Power overvoltage and Power under-voltage protection	User Interface and Main Control PCB	
Protection code			
Error code	Description	Displayed on	
P0	Low-pressure protection	User Interface and Main Control PCB	
P1	High-pressure switch protection	User Interface and Main Control PCB	
P3	Overcurrent protection	User Interface and Main Control PCB	
P4	Compressor protection against excessively-high discharge temperature	User Interface and Main Control PCB	
Pd	Protection for over-high condensing temperature in cooling mode	User Interface and Main Control PCB	
HP	Low-pressure protection in cooling mode	User Interface and Main Control PCB	
bA	T4 sensor out of operation range protection	User Interface and Main Control PCB	
PP	Protection for abnormal temperature difference between outlet water and inlet water	User Interface and Main Control PCB	
Hb	PP occurs 3 times in heating/DHW mode	User Interface and Main Control PCB	
P5	The big temperature difference between outlet water temp. and inlet water temp.	User Interface and Main Control PCB	
F75	Protection for insufficient discharge overheating degree	User Interface and Main Control PCB	
Inverter module error/ protection			
Error code	Description	Displayed on	
F1	Protection for DC bus undervoltage	User Interface and Main Control PCB	For 1Ph units
C7	Over-high temperature protection for IPM module	User Interface and Main Control PCB	
H4	3 times of "L1*" in 60 mins	User Interface and Main Control PCB	
L1E	Hardware overcurrent protection	Main Control PCB	
L11	Phase current instantaneous overcurrent protection	Main Control PCB	
L12	Phase current continuous 30s overcurrent protection	Main Control PCB	
L2E	Over-temperature protection	Main Control PCB	
L3E	Bus voltage too low error	Main Control PCB	
L31	Bus voltage too high error	Main Control PCB	
L32	Bus voltage excessively high error	Main Control PCB	
L34	Phase loss error of three-phase power supply	Main Control PCB	For 3Ph units
L43	Abnormal phase current sampling bias	Main Control PCB	
L45	Fan motor code mismatch error	Main Control PCB	
L46	IPM protection (FO)	Main Control PCB	
L47	Module type mismatch	Main Control PCB	
L5E	Motor failed to start	Main Control PCB	
L52	Motor stalling protection	Main Control PCB	
L6E	Phase loss protection	Main Control PCB	
L61	compressor terminals short circuit protection	Main Control PCB	
L65	IPM short circuit protection	Main Control PCB	
LBE	Action of high-pressure switch	Main Control PCB	
LB7	PED bH error	Main Control PCB	

LCE	PFC hardware overcurrent protection	Main Control PCB	For 3Ph units
LC1	Instantaneous overcurrent of PFC software protection	Main Control PCB	For 3Ph units
LC3	PFC low voltage protection	Main Control PCB	For 3Ph units
LC9	Over-temperature protection of PFC module	Main Control PCB	For 3Ph units
LCA	PFC module CBC overcurrent error protection	Main Control PCB	For 3Ph units
LCB	Overvoltage of PFC bus or PFC half bus	Main Control PCB	For 3Ph units
LCC	Short circuit of PFC IGBT	Main Control PCB	For 3Ph units
LCD	Abnormal PFC Ad sampling bias	Main Control PCB	For 3Ph units
H6	Fan failure	User Interface and Main Control PCB	
HH	10 times of H6 in 120mins	User Interface and Main Control PCB	
J1E	Hardware overcurrent protection	Main Control PCB	
J11	Phase current instantaneous overcurrent protection	Main Control PCB	
J12	Phase current continuous 30s overcurrent protection	Main Control PCB	
J2E	Over-temperature protection	Main Control PCB	
J3E	Bus voltage too low error	Main Control PCB	
J31	Bus voltage too high error	Main Control PCB	
J32	Bus voltage excessively high error	Main Control PCB	
J43	Abnormal phase current sampling bias	Main Control PCB	
J45	Fan motor code mismatch error	Main Control PCB	
J46	IPM Protection (FO)	Main Control PCB	
J47	Module type mismatch (after module resistance tested)	Main Control PCB	
J5E	Motor failed to start	Main Control PCB	
J52	Motor stalling protection	Main Control PCB	
J6E	Phase loss protection	Main Control PCB	
J61	Fan terminals short circuit protection	Main Control PCB	
J65	IPM short circuit protection	Main Control PCB	
HF	Outdoor unit EEPROM error	User Interface and Main Control PCB	
Others			
Error code	Description	Displayed on	
Pb	Pb is the indicator that shows the system is running in anti-freezing control	Main Control PCB	
CL	Water pump communication wire fault	Main Control PCB	
IBH-related error			
Error code	Description	Displayed on	
C2	Relay adhesion on IBH PCB	User Interface and Main Control PCB	For Units with IBH
C3	Current transformer failure or circuit failure of IBH PCB	User Interface and Main Control PCB	For Units with IBH
C4	C3 ≥ 3 times	User Interface and Main Control PCB	For Units with IBH
Refrigerant sensor -related error			
Error code	Description	Displayed on	
A1	The refrigerant leakage detected.	User Interface and Main Control PCB	For units DIP set refrigerant sensor available
A21	The refrigerant sensor malfunction.	User Interface and Main Control PCB	
A22	The refrigerant sensor communication fault.	User Interface and Main Control PCB	
A23	The refrigerant sensor ends of life fault	User Interface and Main Control PCB	

6 Troubleshooting

6.1 Warning

WARNING!

- All electrical work must be carried out by competent and suitably qualified, certified and accredited professionals and in accordance with all applicable legislation (all national, local and other laws, standards, codes, rules, regulations and other legislation that apply in a given situation).
- Power-off the outdoor units before connecting or disconnecting any connections or wiring, otherwise electric shock (which can cause physical injury or death) may occur or damage to components may occur.

6.2 E0, E8 Troubleshooting

6.2.1 Digital display output

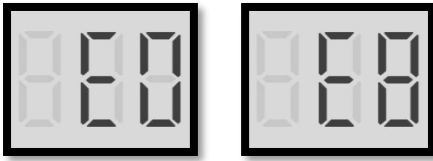

6.2.2 Description

Error code		E0	E8
Description		water flow failure	water flow protection
Triggering		5 times of No-water detection failures in a row before pump on Or 10 times of E8 in a row when do running-water detection after pump on	No-water detection failures before pump on or water flow switch breaks after pump on within 10 times
Relative ports and Locations	CN28 PUMP (To supply power for water pump)		
	CN17 PUMP BP (feedback signal of water pump)		
	CN8 FS (signal of water flow switch)		

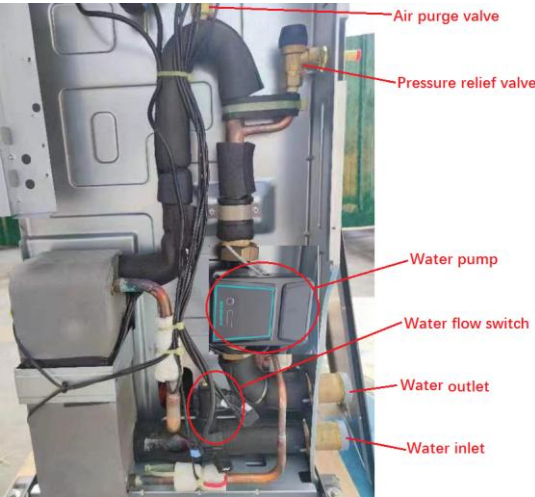
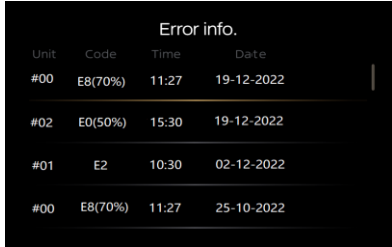
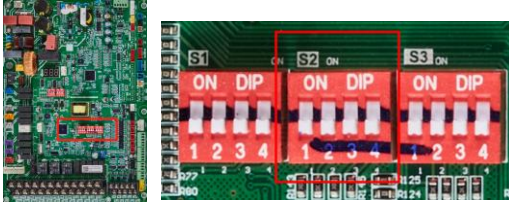
<p>Layout of main component</p>																					
<p>User Interface</p>	<p>E0(**%) /E8(**%) is displayed on the User Interface. The percentage indicates possible cause of water flow failure, which is illustrated as note 1.</p>  <table border="1"> <thead> <tr> <th>Unit</th> <th>Code</th> <th>Time</th> <th>Date</th> </tr> </thead> <tbody> <tr> <td>#00</td> <td>E8(70%)</td> <td>11:27</td> <td>19-12-2022</td> </tr> <tr> <td>#02</td> <td>E0(50%)</td> <td>15:30</td> <td>19-12-2022</td> </tr> <tr> <td>#01</td> <td>E2</td> <td>10:30</td> <td>02-12-2022</td> </tr> <tr> <td>#00</td> <td>E8(70%)</td> <td>11:27</td> <td>25-10-2022</td> </tr> </tbody> </table>	Unit	Code	Time	Date	#00	E8(70%)	11:27	19-12-2022	#02	E0(50%)	15:30	19-12-2022	#01	E2	10:30	02-12-2022	#00	E8(70%)	11:27	25-10-2022
Unit	Code	Time	Date																		
#00	E8(70%)	11:27	19-12-2022																		
#02	E0(50%)	15:30	19-12-2022																		
#01	E2	10:30	02-12-2022																		
#00	E8(70%)	11:27	25-10-2022																		
<p>Correct Dip switch</p>	 <table border="1"> <tr> <td rowspan="2">S2</td> <td>1/2</td> <td>Reserved</td> <td>1:OFF 2:OFF</td> </tr> <tr> <td>3/4</td> <td>0/0=variable speed pump 1 0/1=variable speed pump 2 1/0=Fixed speed pump 1/1=Reserved</td> <td>3:OFF 4:OFF</td> </tr> </table>	S2	1/2	Reserved	1:OFF 2:OFF	3/4	0/0=variable speed pump 1 0/1=variable speed pump 2 1/0=Fixed speed pump 1/1=Reserved	3:OFF 4:OFF													
S2	1/2		Reserved	1:OFF 2:OFF																	
	3/4	0/0=variable speed pump 1 0/1=variable speed pump 2 1/0=Fixed speed pump 1/1=Reserved	3:OFF 4:OFF																		

6.2.3 Procedure

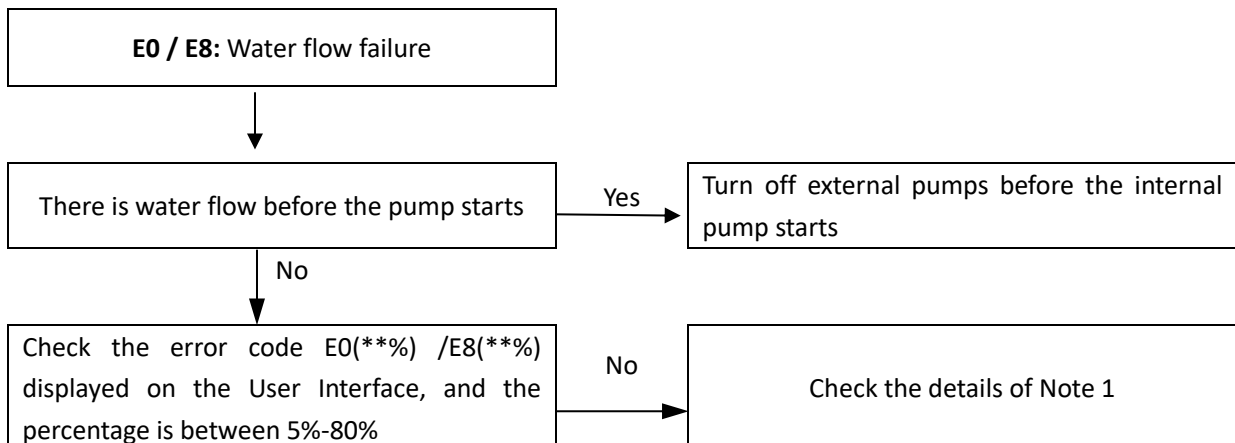

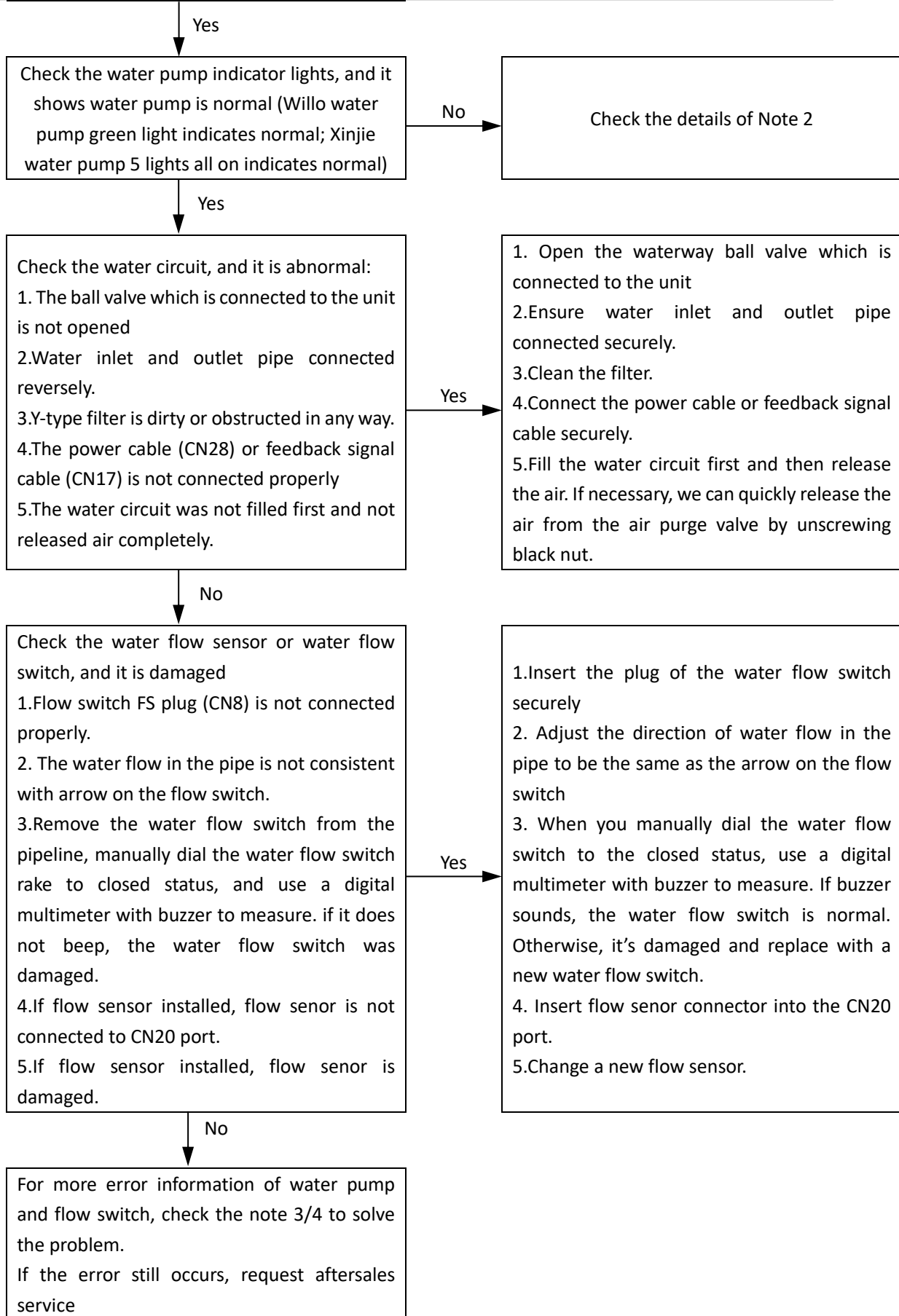

Note 1 :

The meaning of percentage of water pump output(displayed on the user interface)			
Percentage	Water pump model	Brand	Description
0%	Para 25/9 IPWM-130-1	WILO	IPWM connection port short circuited
	APM25-9-130/180	SHIMGE	PWM feedback signal loss
2%	Para 25/9 IPWM-130-1	WILO	Pump Standby
	APM25-9-130/180	SHIMGE	Pump Standby
	APM25-9-130/180	SHIMGE	Pump Standby
80%	Para 25/9 IPWM-130-1	WILO	Undervoltage < 160/170-194V, and Pump keeps running
	APM25-9-130/180	SHIMGE	Alarm, and Pump keeps running (Low voltage: 170-194V; High voltage: 250-270V)
85%	Para 25/9 IPWM-130-1	WILO	Undervoltage < 160/170V; Overvoltage > 253V-264V; Motor overload; module overheat; external pump flow rate larger than internal pump flow rate, Pump shuts off
	APM25-9-130/180	SHIMGE	Alarm, and pump shuts off (Low voltage: <170V/ High voltage: >270V)
90%	Para 25/9 IPWM-130-1	WILO	Motor overspeed; over current; underspeed; pump stalling, and pump shuts off
	APM25-9-130/180	SHIMGE	Alarm (Pump idling , pump stalling) and pump shuts off
95%	Para 25/9 IPWM-130-1	WILO	Pump damaged; circuit damaged; terminal damaged, and pump shuts off
	APM25-9-130/180	SHIMGE	Alarm; Phase loss; Overcurrent error, and pump shuts off
100%	Para 25/9 IPWM-130-1	WILO	IPWM connection port open circuited
	APM25-9-130/180	SHIMGE	No PWM signal input

Note 2 – Indicator lights on Xinjie water pump :

Indicator lights on Xinjie water pump		
Name	Indicator lights	Description
motor stalling protection		When motor stalling happens, the pump tries to reboot every 5s, and indicator lights shows the error. After 5 times reboot, pump shuts off
Overcurrent/ Undercurrent protection		When low voltage: <165V/ high voltage: >275V, pump shuts off and indicator lights shows the error. When the voltage is back to 160V-270V, pump resume running
Phase loss protection		When phase loss happens, the pump tries to reboot every 1s, and indicator lights shows the error. After 5 times reboot, pump shuts off
Overcurrent (Short circuit) protection		When overcurrent / overheat happens, the pump tries to reboot every 1s, and indicator lights shows the error. After 5 times reboot, pump shuts off
Overheat protection		When power module overheat, pump shuts off and indicator lights shows the error.

M thermal Nature Plus Series



Note 3: The possible error and solutions of water pump

The possible causes of water pump failure and solutions		
Description	Possible cause	Solution
Error occurs at the first time running	Water pump leak	Replace the sealing ring
	Water inlet and outlet pipe connected reversely.	Connect the pipe securely.
	The power cable (CN28) is not connected properly	Connect the power cable securely.
	The feedback signal cable (CN17) is not connected properly	Connect the feedback signal cable securely.
	The dip switch is not correct.	Correct the dip switch as the illustration above
Error occurs at the first time running or after running for a while	Pump idling	Fill the water circuit first and then release the air
	Pump stalling	Remove the water pump, Rotate the impeller manually until it can move freely. And then install it back. (If it's too hard to rotate the impeller manually, replace the water pump)
	Power supply is abnormal	Check the power supply
Error occurs after running for a while	E8 occurs after water pump running for a while	Fill the water circuit first and then release the air.
Error occurs at the first time running or after running for a while	Motor stall, and it can not be rotated manually	Replace water pump
Error occurs at the first time running	Water pump connection is correct, the water pump icon on the User Interface is lit, while no indicator lights on water pump is lit.	Replace water pump

Note 4: The possible error and solutions of water flow switch failure

The possible causes of water flow switch failure and solutions		
Description	Possible cause	Solution
Error occurs at the first time running	The water flow in the pipe is not consistent with arrow on the flow switch.	Adjust the direction of water flow in the pipe to be the same as the arrow on the flow switch
	Flow switch FS plug (CN8) is not connected properly.	Insert the plug of the water flow switch securely
	External pump starts before internal pump (PUMPI) starts	Start internal pump first, Ensure water flow is sufficient for external pump
Error occurs at the first time running or after running for a while	Flow switch not installed properly	Reinstall the flow switch securely
	Flow switch leak	Replace the sealing ring
	flow switch rake blocked	Clean the obstacles
	flow switch rake damaged	Replace the flow switch
	The flow switch contact can not be completely closed	Replace the flow switch
	The flow switch contact can not be completely open	Replace the flow switch
The flow switch model did not match	Replace the flow switch	

6.3 E2 Troubleshooting

6.3.1 Digital display output

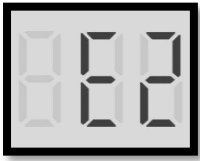

6.3.2 Description

Error code		E2
Description		Communication fault between User Interface and Main Control PCB
Triggering		Main Control PCB side: Communication failure with User Interface lasts 2 mins Or User Interface side: No communication reply from Main Control PCB for 1 min
Relative ports and Locations	X/HA、Y/HB	

6.3.3 Procedure

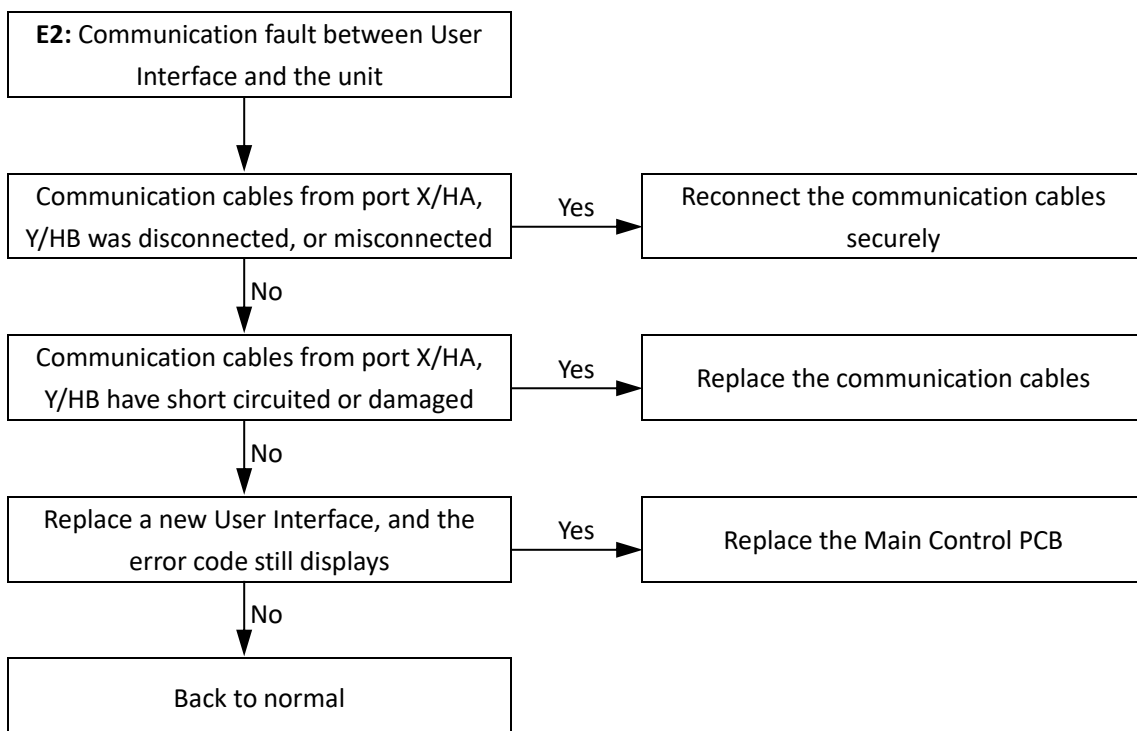

6.4 H0 Troubleshooting

6.4.1 Digital display output



6.4.2 Description

Error code	H0
Description	Communication error of Main Control PCB
Triggering	Communication failure lasts 1 min

6.4.3 Procedure

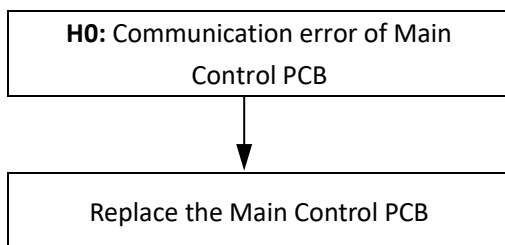

6.5 H1 Troubleshooting

6.5.1 Digital display output



6.5.2 Description

Error code		H1
Description		Communication error between Main Control PCB and inverter PCB
Triggering		Communication failure occurs after powering on the unit for 2 mins
Relative ports and Locations	CN43 COMM (Main Control PCB)	
	LED2 & BUS voltage(P-N) (1 Ph Inverter PCB)	
	LED2 & BUS voltage(P-N) (3 Ph inverter PCB)	<p>You can see the slim light of LED2 through the gap at the back of inverter PCB</p>

6.5.3 Procedure

For 1Ph models

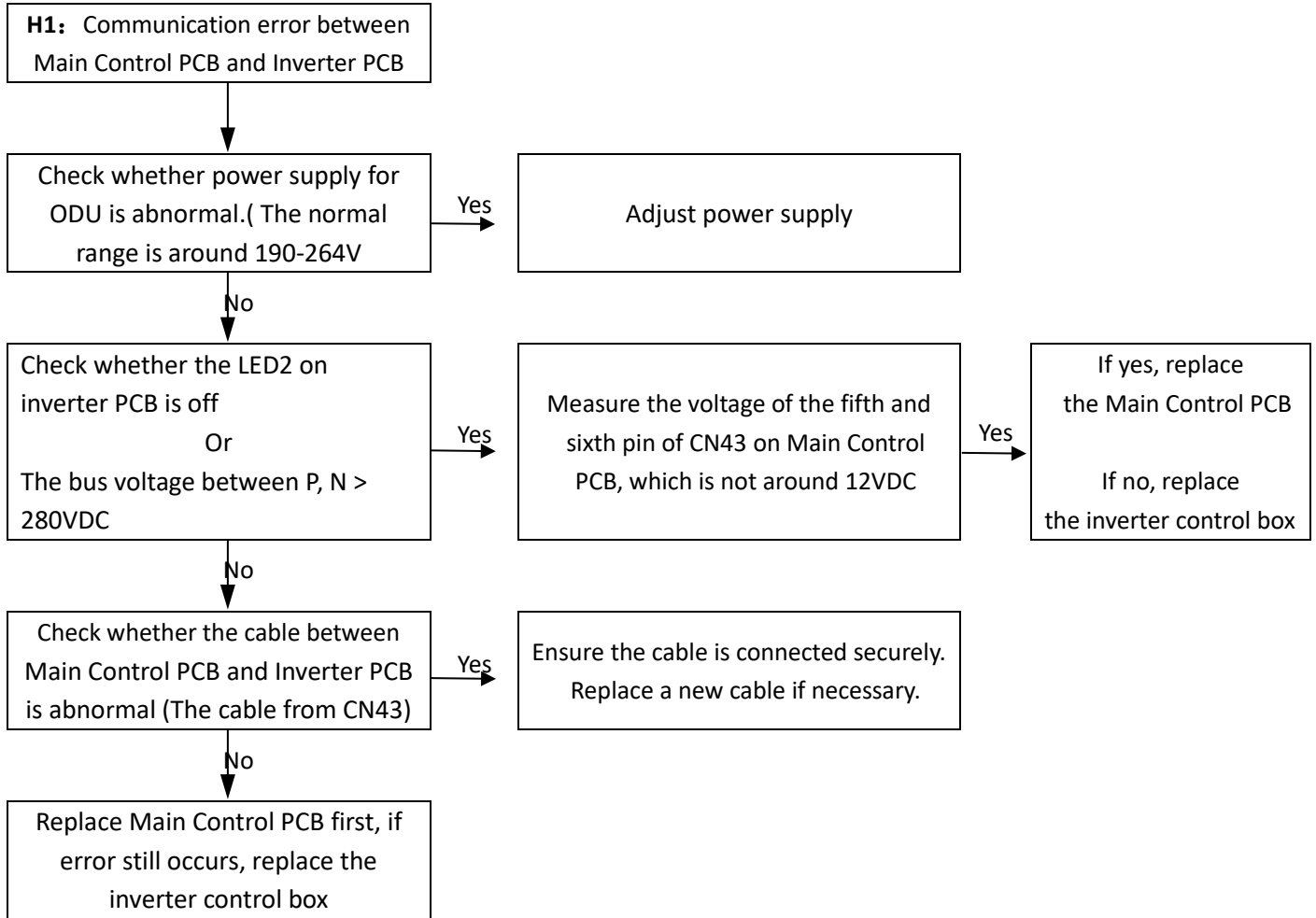

For 3Ph units

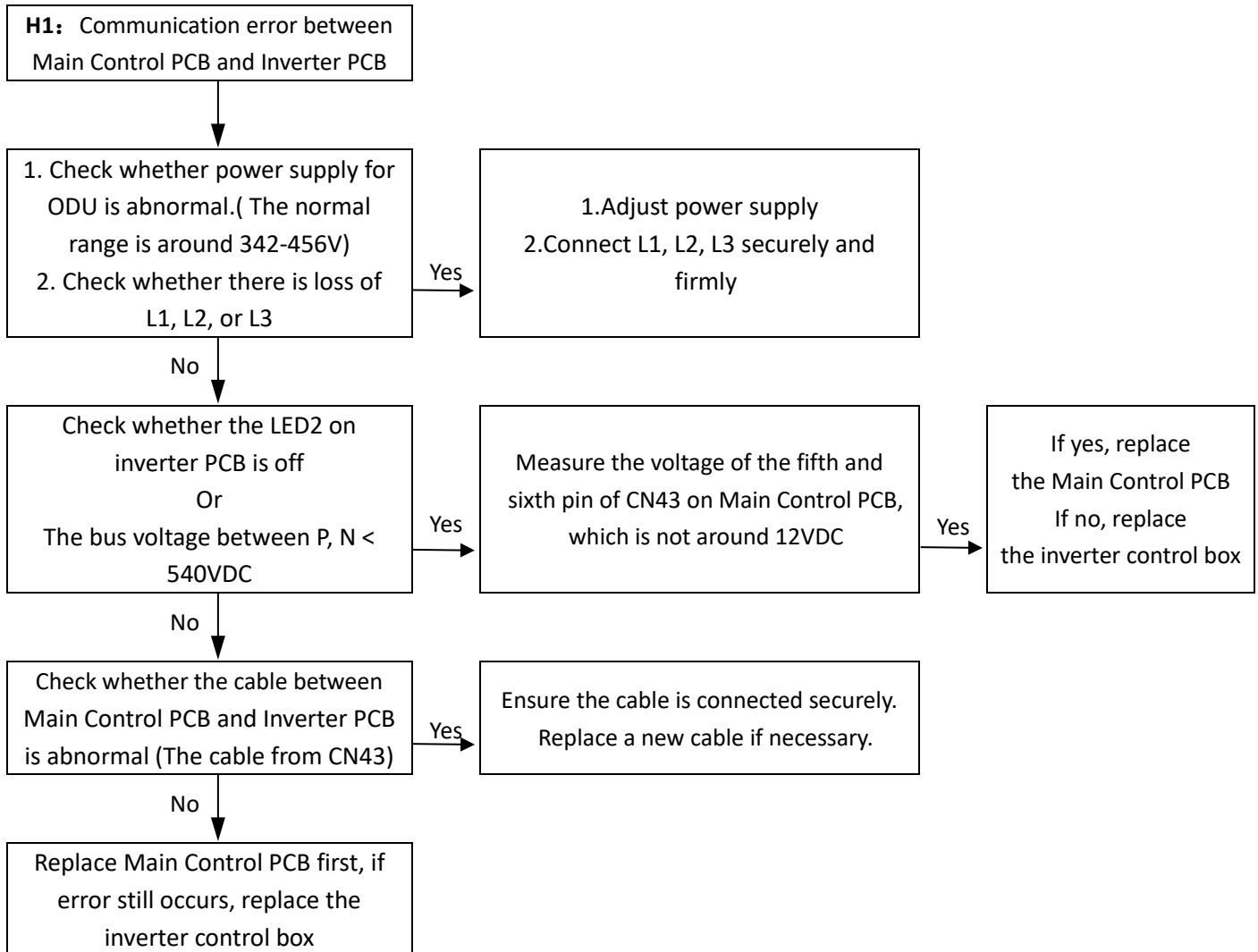



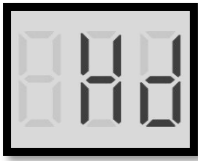

6.6 Hd Troubleshooting

6.6.1 Digital display output

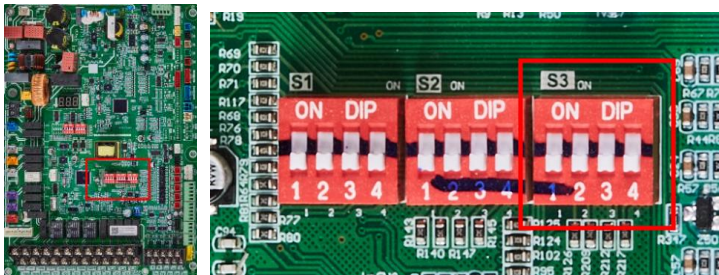

6.6.2 Description

Error code		Hd
Description		Communication fault between master unit and slave unit.
Triggering		For cascade system, the communication failure between master unit and slave unit lasts 2mins and above
Relative ports and Locations	Communication port E1/H1/H2	 
	Dip switch S3-1/2/3 0/0/0=address 0# (Master) 1/0/0=address 1# (Slave) 0/1/0=address 2# (Slave) 0/0/1=address 3# (Slave) 1/1/0=address 4# (Slave) 1/0/1=address 5# (Slave) 0/1/1=address 6# (Slave) 1/1/1=address 7# (Slave)	
	SW9 1/1=master unit 0/0=slave unit	 

6.6.3 Procedure

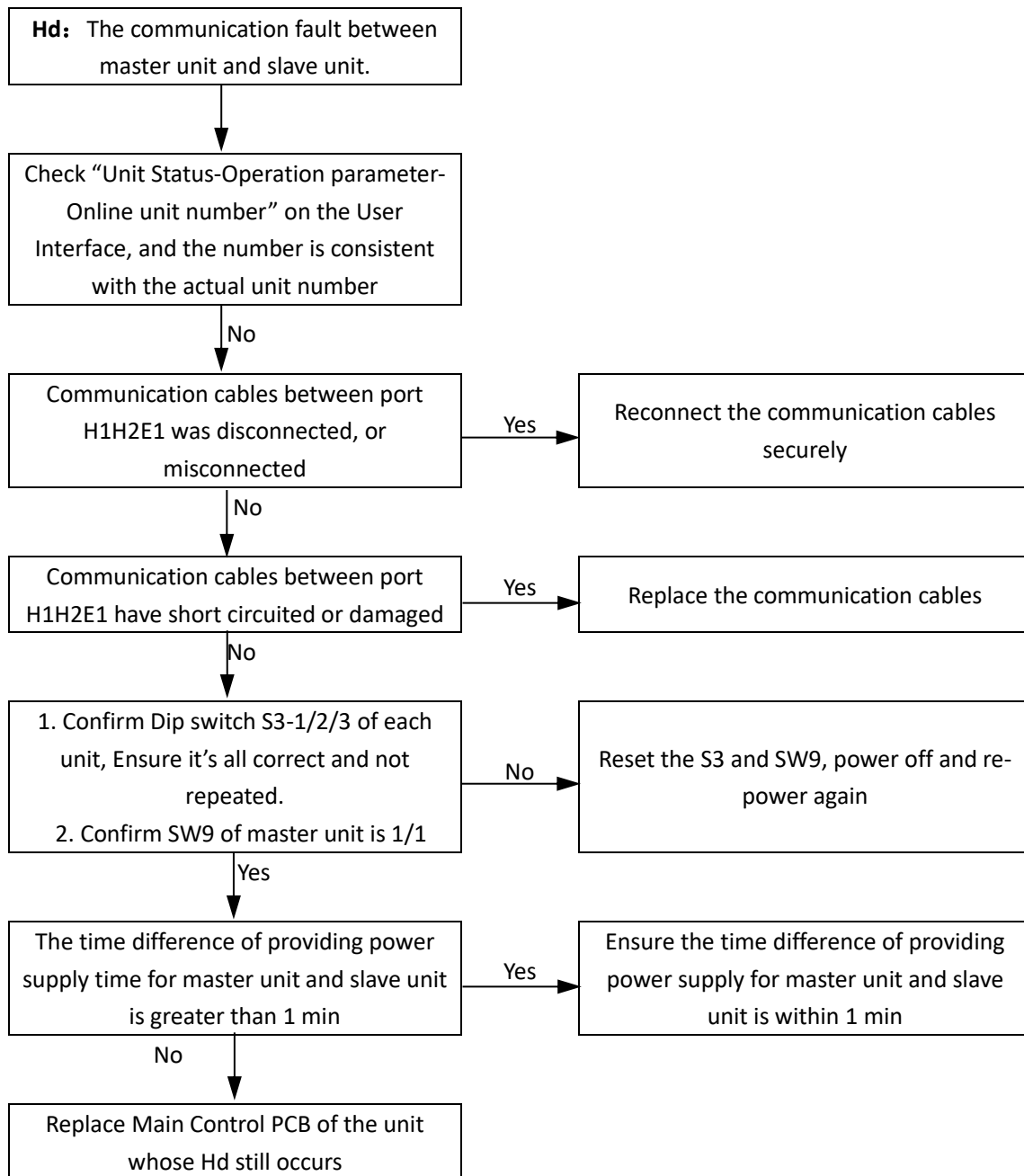

6.7.3 Procedure

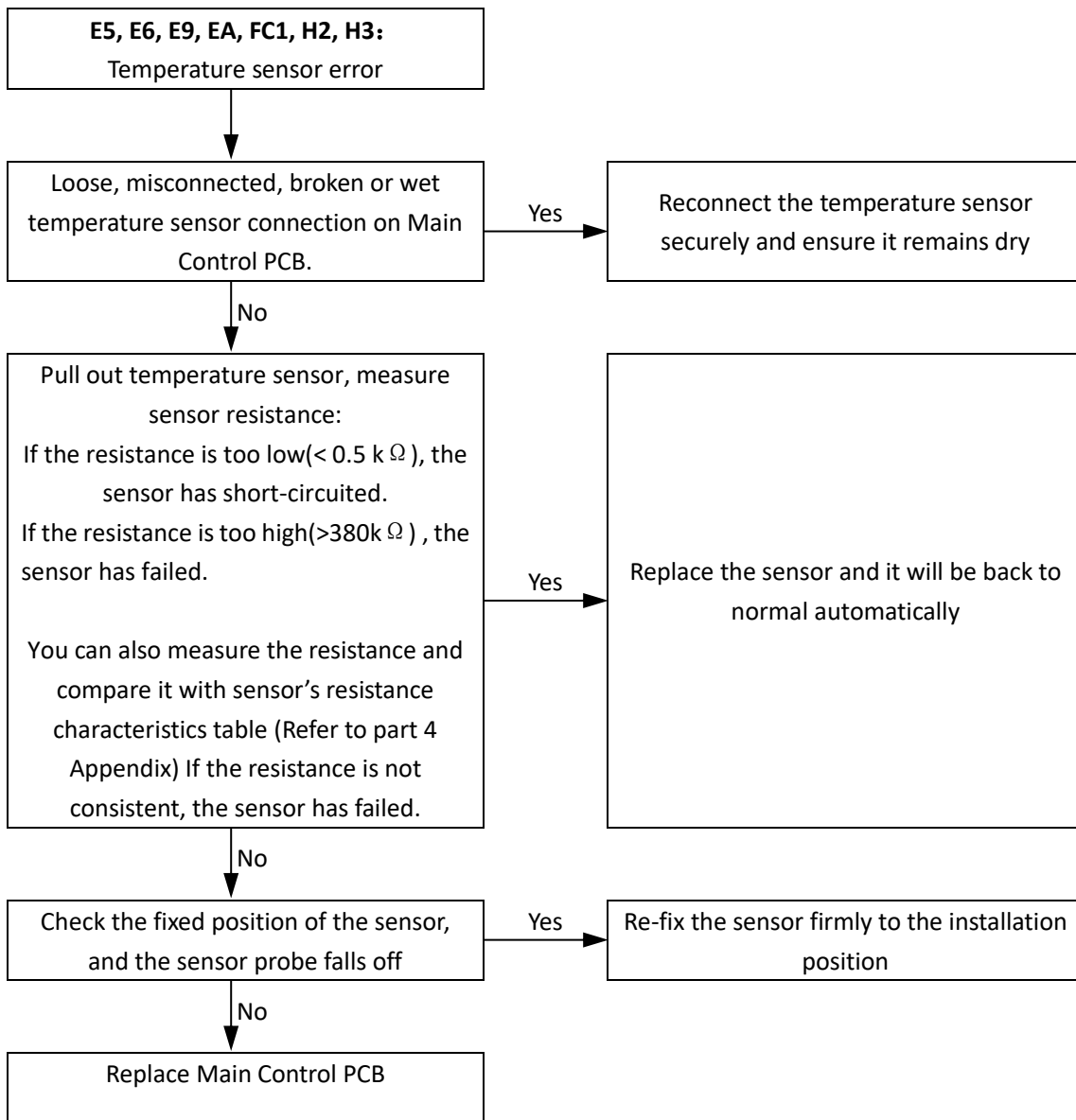

6.8 E3, E4, E7, Eb, EC, Ed, HA, H9 Troubleshooting

6.8.1 Digital display output

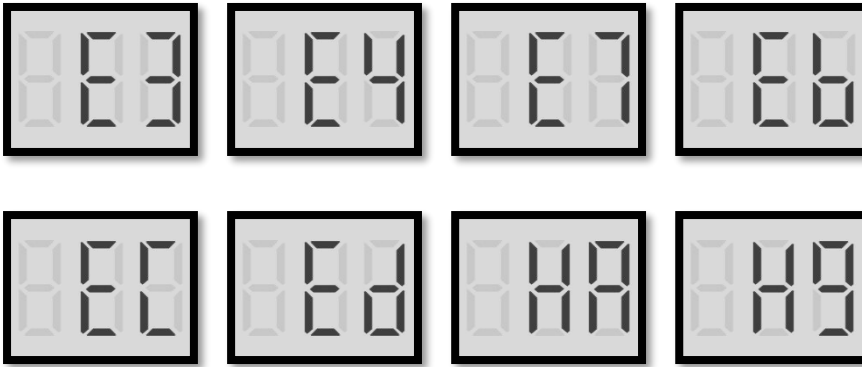

6.8.2 Description

Code	Description	Port	Locations (Main Control PCB)
E3	T1 Electric Heater/AHS water outlet temperature sensor error	CN39	
E4	T5 Water tank temperature sensor error	CN13	
E7	Tbt Balance tank temperature sensor/ Final outlet water temperature of cascade system sensor error	CN24	
Eb	Tsolar Solar panel temperature sensor error	CN18	
EC	T5_2 Water tank temperature sensor error (Reserved)	CN38	
Ed	Tw_in Plate heat exchanger inlet water temperature sensor error	CN10	
HA	Tw_out Plate heat exchanger outlet water temperature sensor error		
H9	Tw2 Zone 2 water flow temperature sensor error	CN15	

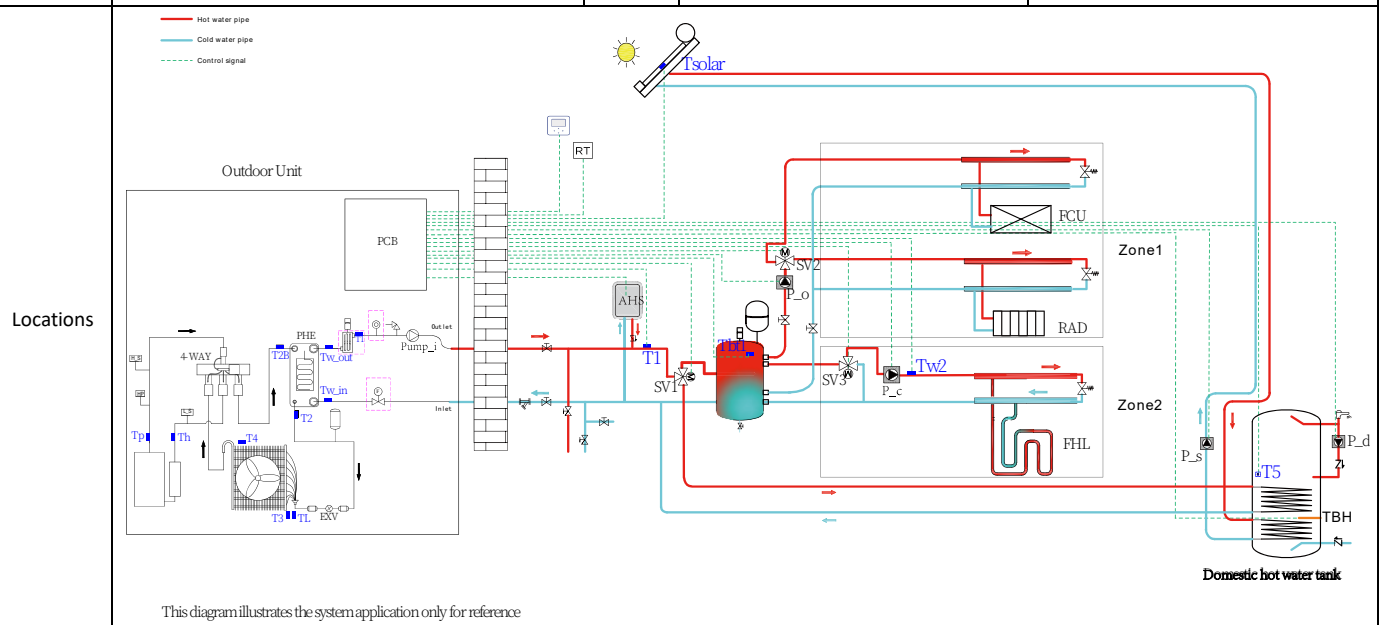

Dip Switch S1	IBH Dip switch																
		<table border="1"> <thead> <tr> <th>DIP switch</th> <th>ON=1</th> <th>OFF=0</th> <th>FACTORY SETTINGS</th> </tr> </thead> <tbody> <tr> <td rowspan="4">S1</td> <td>1</td> <td>Reserved</td> <td>1:OFF</td> </tr> <tr> <td>2</td> <td>0= Integrated electric heater 1= External electric heater</td> <td>2:OFF</td> </tr> <tr> <td rowspan="2">3/4</td> <td>0/0=No IBH 0/1=With IBH (One-step control)</td> <td rowspan="2">3:OFF 4:OFF</td> </tr> <tr> <td>1/0=With IBH (Two-step control) 1/1=With IBH (Three-step control)</td> </tr> </tbody> </table>	DIP switch	ON=1	OFF=0	FACTORY SETTINGS	S1	1	Reserved	1:OFF	2	0= Integrated electric heater 1= External electric heater	2:OFF	3/4	0/0=No IBH 0/1=With IBH (One-step control)	3:OFF 4:OFF	1/0=With IBH (Two-step control) 1/1=With IBH (Three-step control)
DIP switch	ON=1	OFF=0	FACTORY SETTINGS														
S1	1	Reserved	1:OFF														
	2	0= Integrated electric heater 1= External electric heater	2:OFF														
	3/4	0/0=No IBH 0/1=With IBH (One-step control)	3:OFF 4:OFF														
		1/0=With IBH (Two-step control) 1/1=With IBH (Three-step control)															

Note 1: Dip switch settings or User Interface settings

Code	Description
Ed	Main Control PCB can not detect the right sensor value.
HA	
E3	IBH function is on(Dip switch S1-3/4 is set IBH available, and User Interface- For Serviceman - Other heat source – IBH function=1) , while Main Control PCB can not detect the right T1 sensor value. AHS function is on (User Interface- For Serviceman - Other heat source - AHS function=1), while Main Control PCB can not detect the right T1 sensor value.
E4	DHW mode is on (User Interface- For Serviceman – DHW setting- DHW mode=1), while Main Control PCB can not detect the right T5 sensor value.
E7	Tbt is on (User Interface- For Serviceman- Input definition- Tbt=1), while Main Control PCB can not detect the right Tbt sensor value.
Eb	Solar function is on and Solar control is on (User Interface- For Serviceman - Other heat source - Solar function=1 & Solar control=1), while Main Control PCB can not detect the right Tsolar sensor value.
EC	T5_2 is on (User Interface- For Serviceman- Input definition- Tbt=1), while Main Control PCB can not detect the right T5_2 sensor value. (Reserved)
H9	Double zone is on(User Interface- For Serviceman –Temp. type setting – Double zone=1), while Main Control PCB can not detect the right Tw2 sensor value.

6.8.3 Procedure

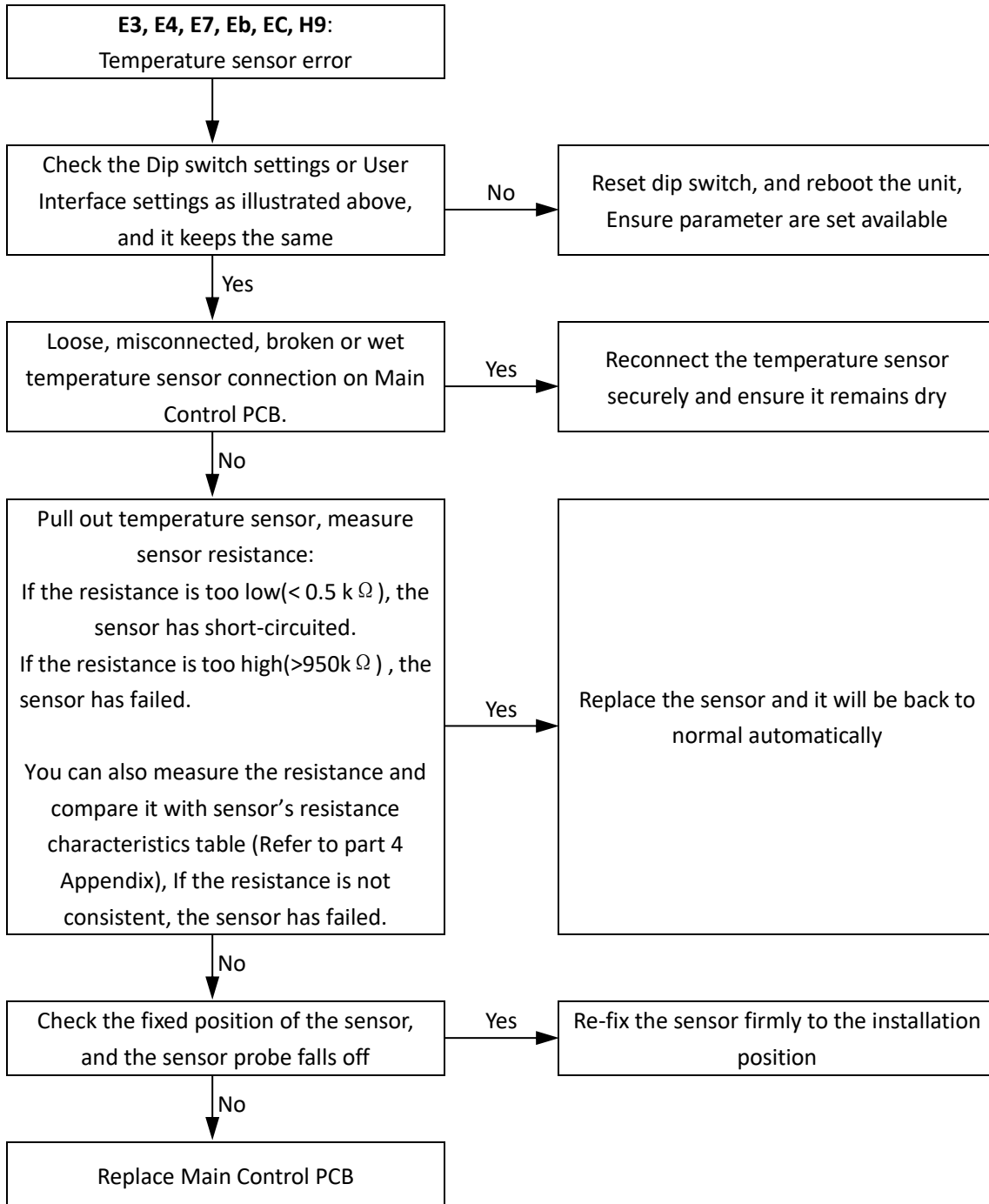

6.9 H5 Troubleshooting

6.9.1 Digital display output



6.9.2 Description

Code	Description	Locations
H5	Ta room temperature sensor error	Inserted on User Interface PCB

6.9.3 Procedure

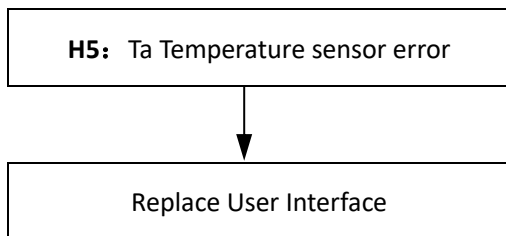

6.10 H8, P21, P27 Troubleshooting

6.10.1 Digital display output



6.10.2 Description

Code	Description	Port	Locations(Main Control PCB)
H8	H-SEN High-pressure sensor error	CN3	
P21	L-SEN Low-pressure sensor error	CN46	
P27	H-SEN and L-SEN connected in reverse (detect when compressor is off)	CN3/ CN46	

6.10.3 Procedure

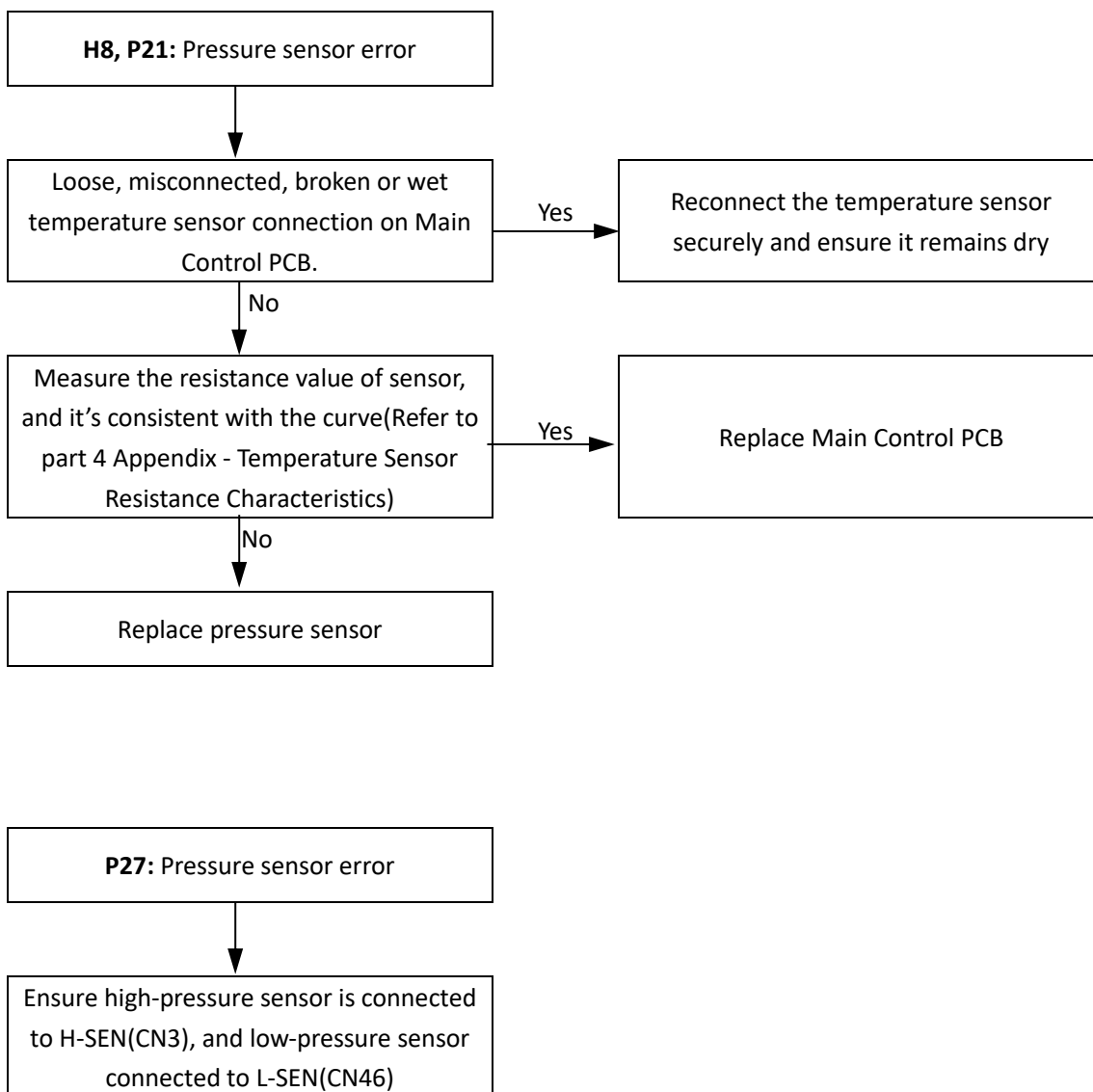

6.11 E1 Troubleshooting

6.11.1 Digital display output



6.11.2 Description

Error code		E1 (For 3Ph units)
Description		Phase loss or phase reversal
Triggering		At least one of L1/L2/L3/N is misconnected or disconnected
Relative ports and Locations	Terminal blocks	

6.11.3 Procedure

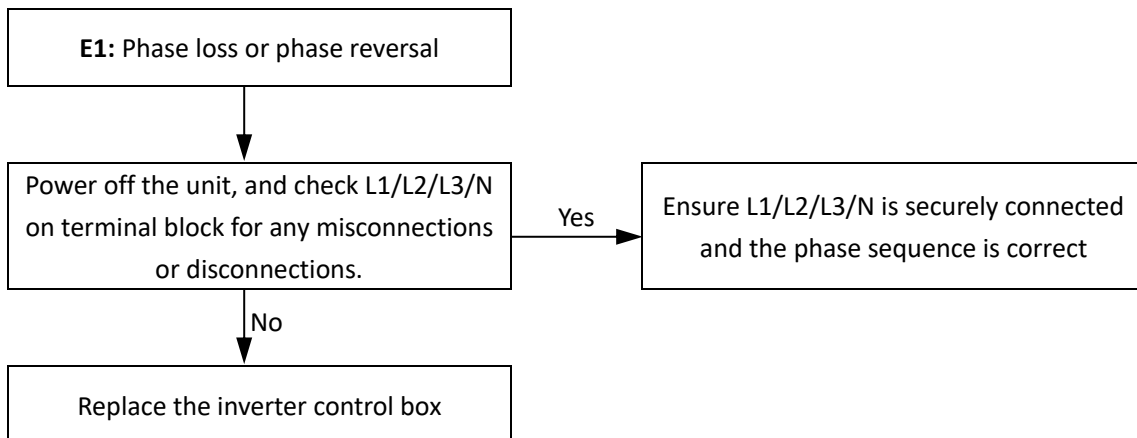

6.12 H7 Troubleshooting

6.12.1 Digital display output



6.12.2 Description

Error code	H7
Description	Power overvoltage and power undervoltage protection
Triggering	Input voltage <math><170V</math> or Input voltage $\geq 265V</math>(The unit operating normally if 250V \geq \text{input voltage} \geq 180V</math>)$

6.12.3 Procedure

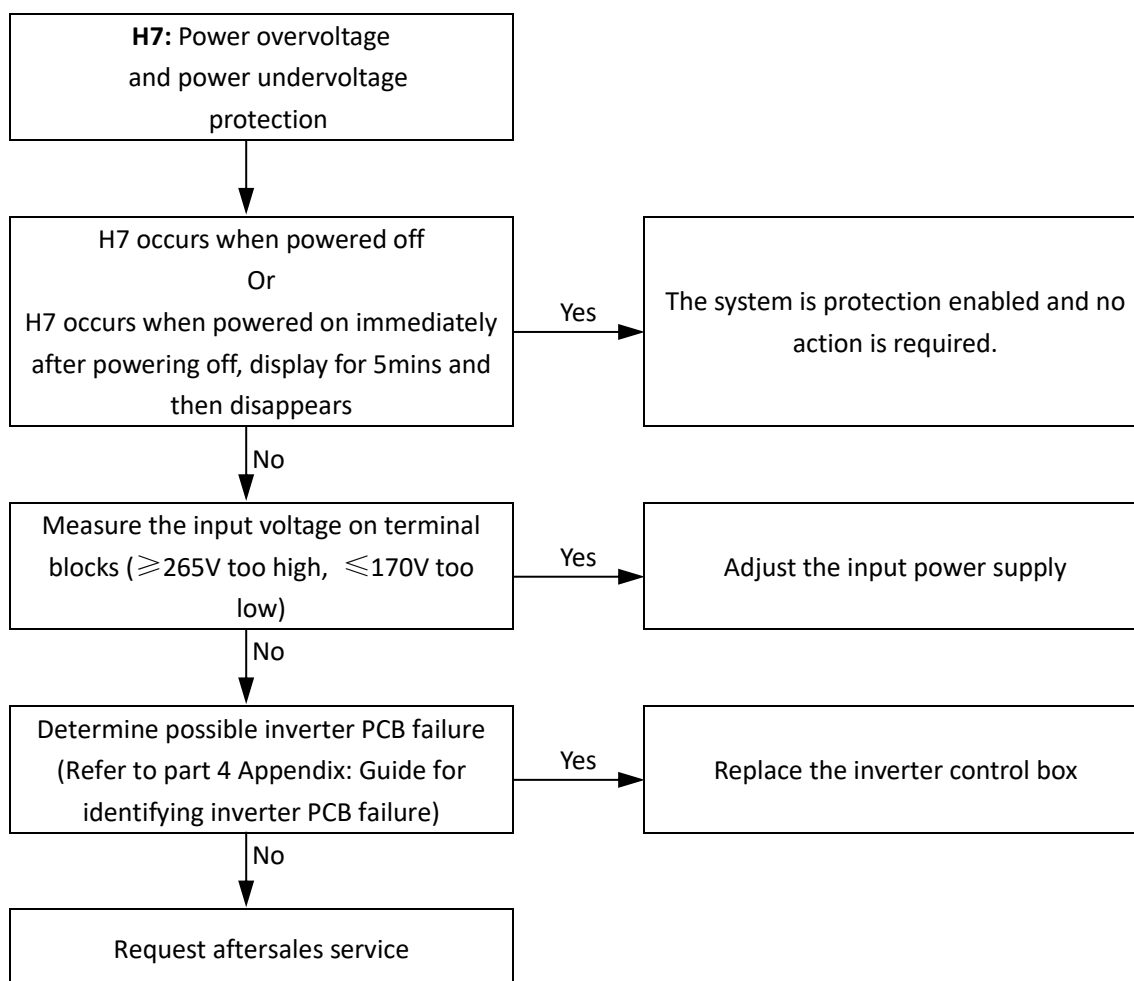

6.13 P0 Troubleshooting

6.13.1 Digital display output

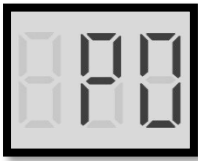

6.13.2 Description

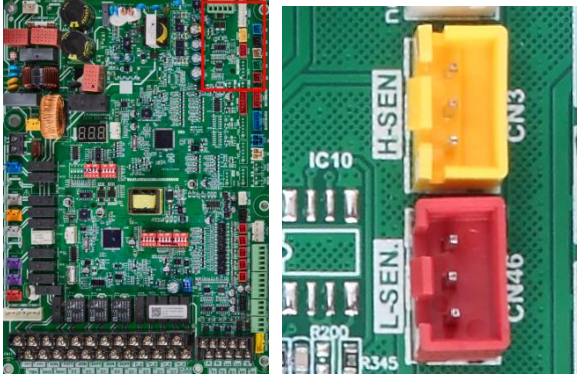
Error code	P0
Description	Low-pressure protection
Triggering	<ol style="list-style-type: none"> 1. Main Control PCB detected that the low pressure <0.12MPa lasting more than 30 mins 2. Main Control PCB detected that low pressure <0.13MPa & compressor shutting off more than 2 mins at the same time. 3. Main Control PCB detected that low pressure <0.13MPa & compressor is running ($T_4 \geq -10^{\circ}\text{C}$ ambient condition) except defrost and forced cooling operation status
H-SEN and L-SEN Locations	

6.13.3 Procedure

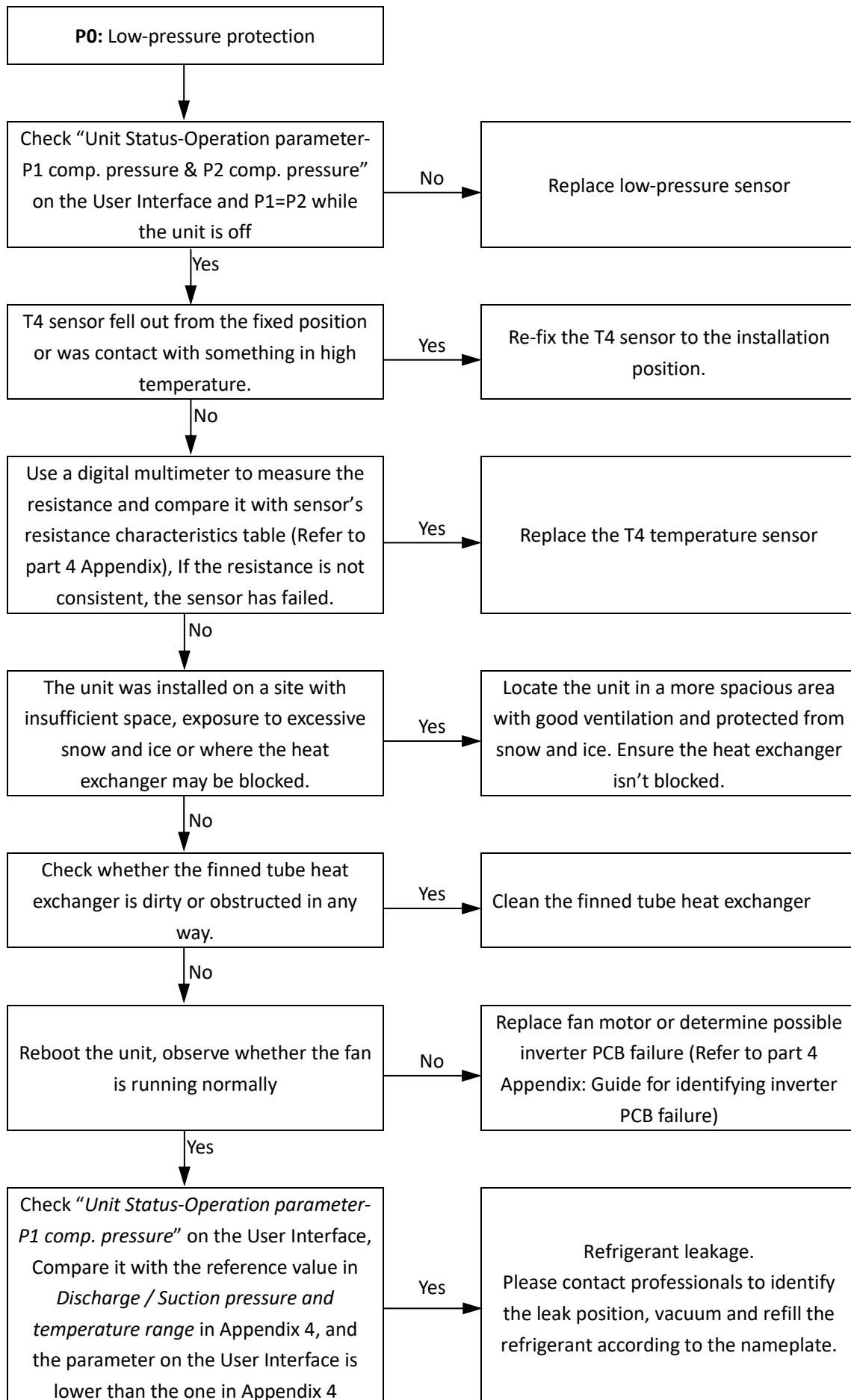

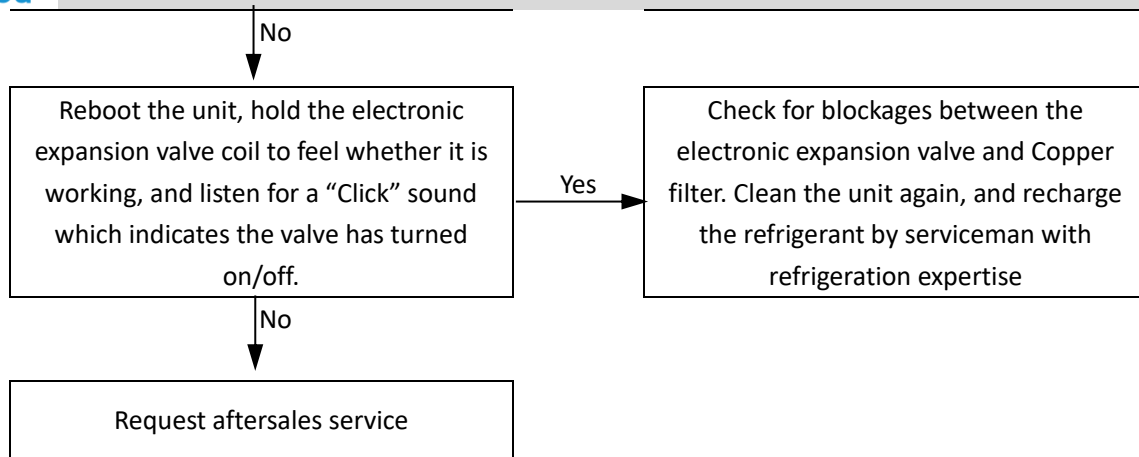

6.14 P1 Troubleshooting

6.14.1 Digital display output



6.14.2 Description

Error code	P1
Description	High-pressure switch protection
Triggering	Main Control PCB detected high-pressure ≥ 3.5 Mpa
High-pressure switch Locations	The Locations of high-pressure switch refer to Part 2, Component Layout and Refrigerant Circuits
High-pressure switch plug	<p>The Cables from Inverter Control box</p> <p>Note: cable locations may vary depending on model.</p>

6.14.3 Procedure

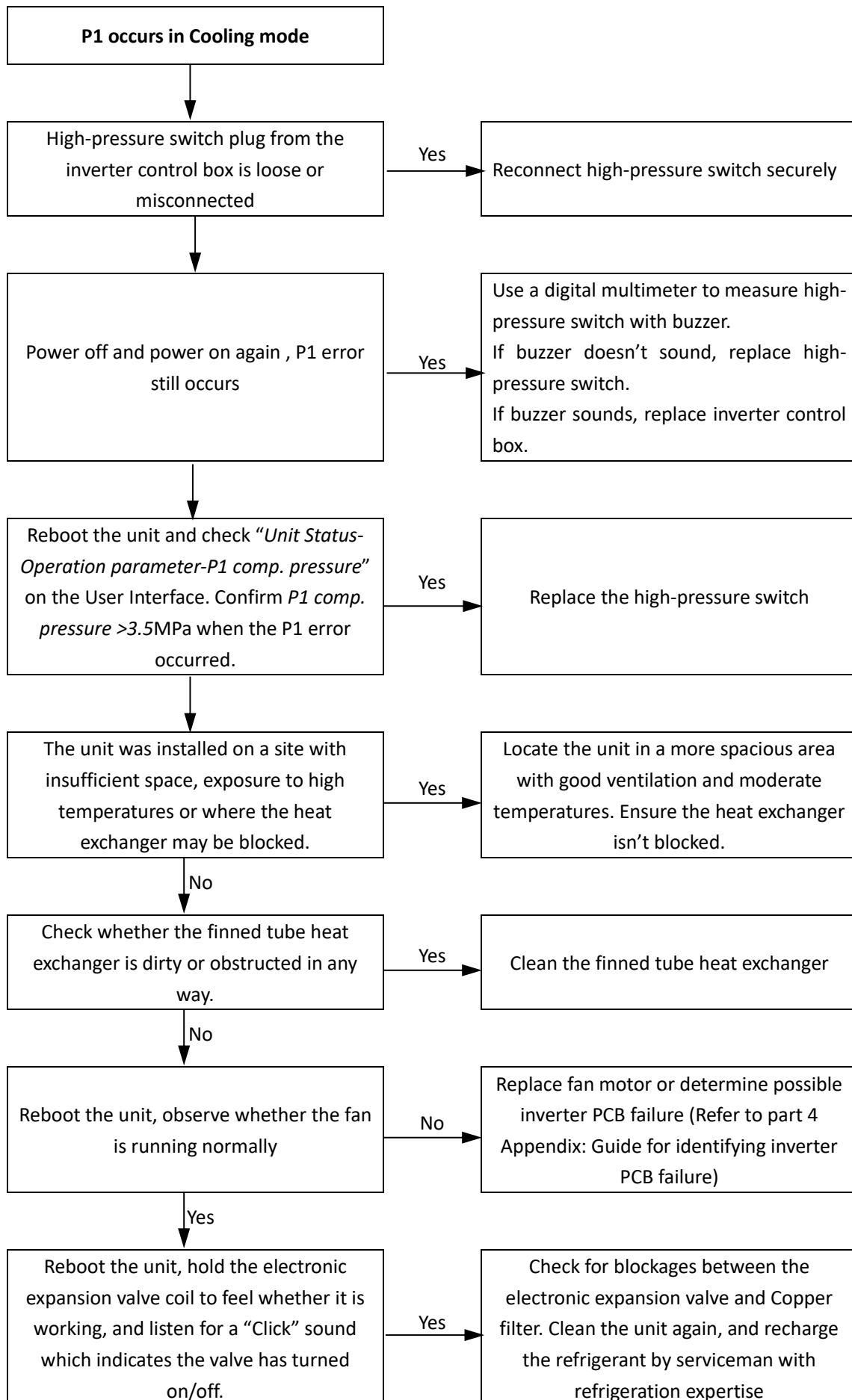

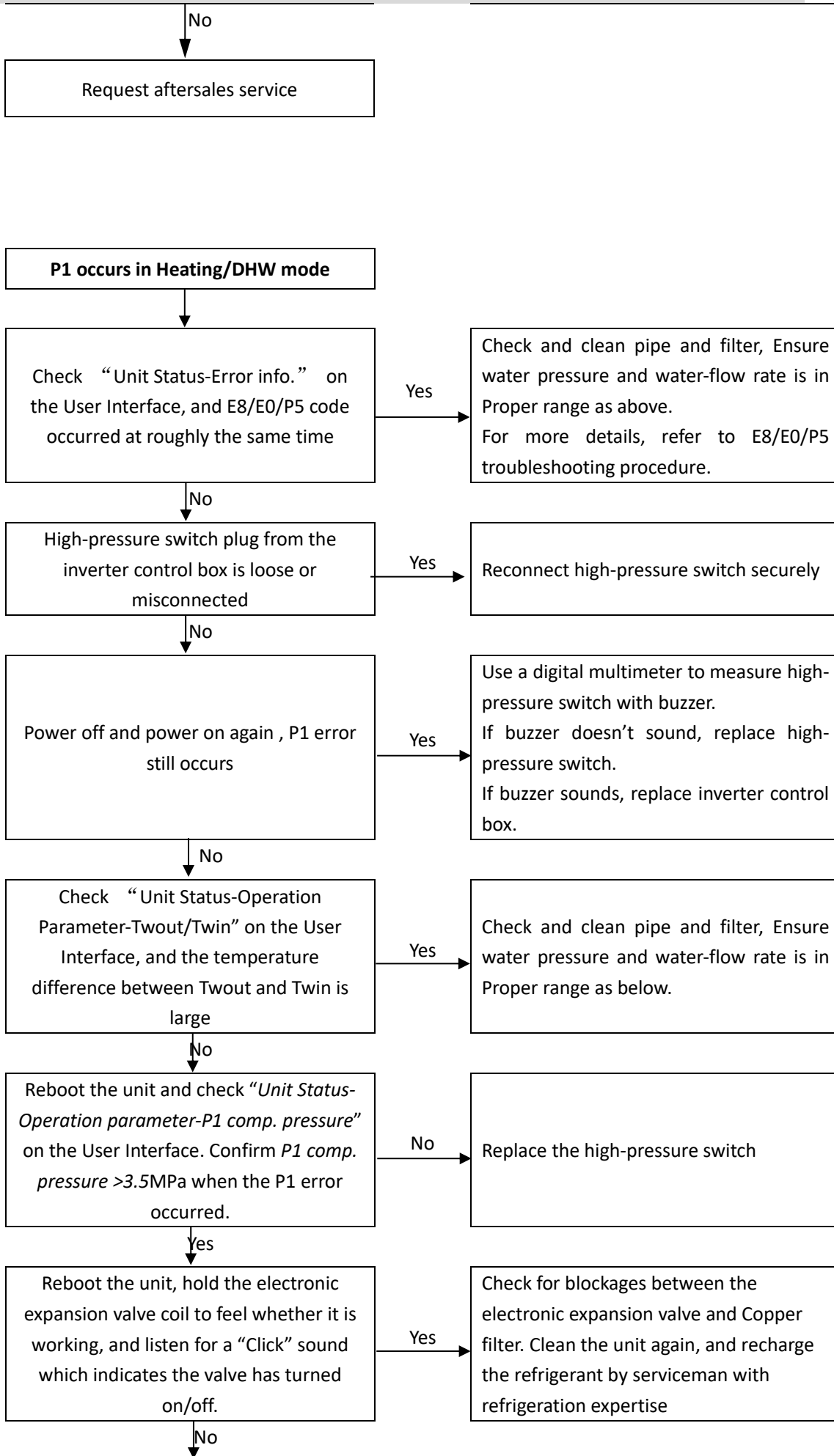

Replace the inverter control box

The proper water pressure range:(0.3bar-3bar)

- The water pressure will vary with the water temperature (a higher pressure at a higher water temperature). Always keep the water pressure above 0.03 MPa(0.3 bar) to prevent air from entering the loop.
- The unit might drain off too much water through the pressure relief valve.

Maximum water pressure 0.3 MPa(3 bar)

The proper water flow rate range

Unit	Flow rate range(m ³ /h)
8 kW	0.40 - 1.65
10 kW	0.40 - 2.10
12 kW	0.70 - 2.50
14 kW	0.70 - 2.75
16 kW	0.70 - 3.00

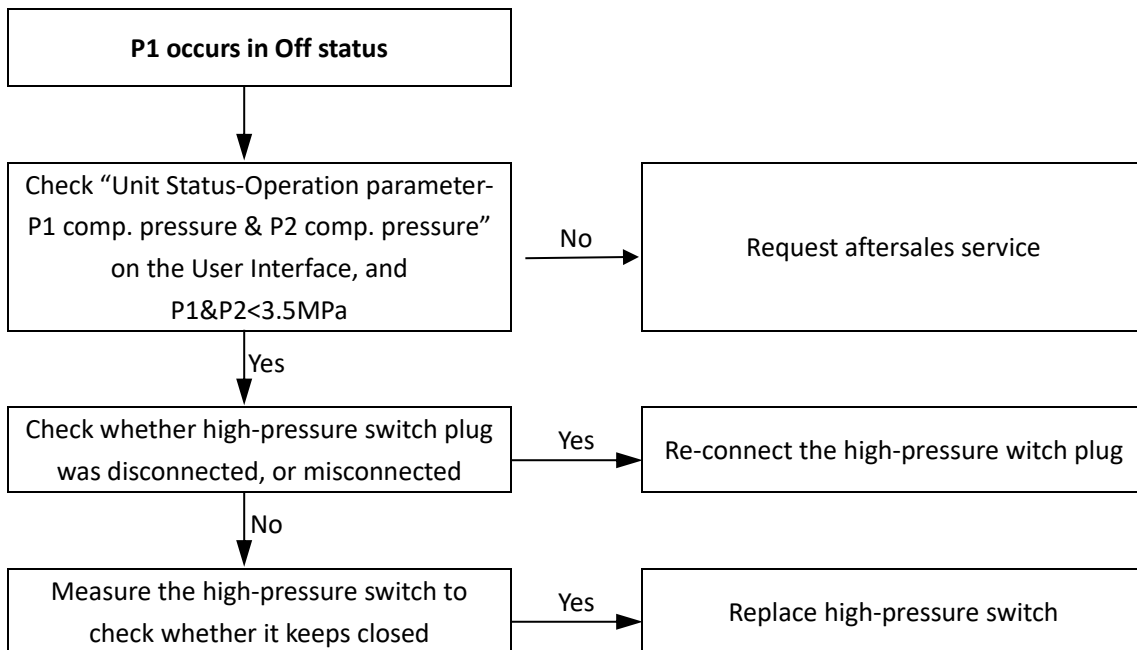

6.15 P3 Troubleshooting

6.15.1 Digital display output



6.15.2 Description

Error code	P3
Description	Overcurrent protection
Triggering	Main Control PCB detected that the input current is higher than protection value
Terminal block	

6.15.3 Procedure

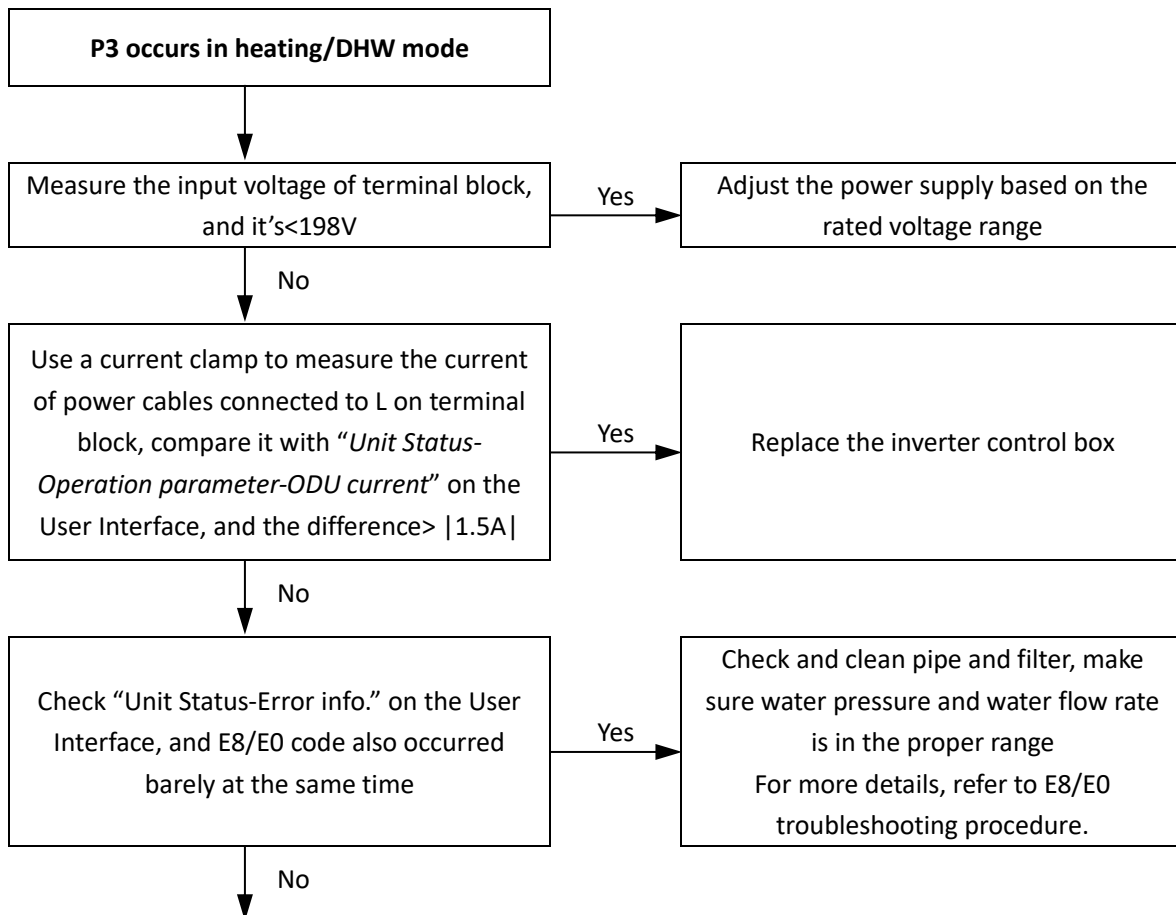

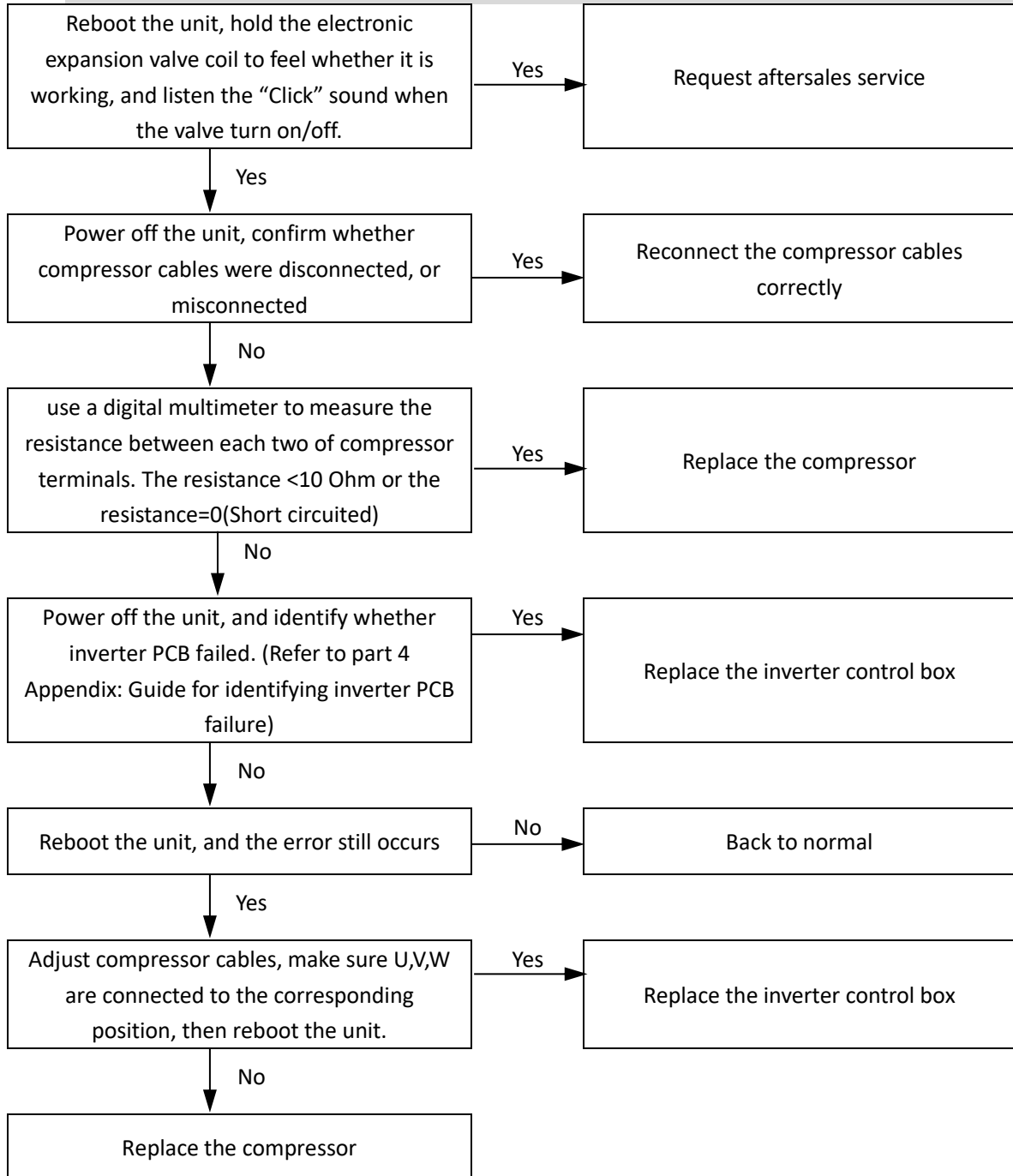



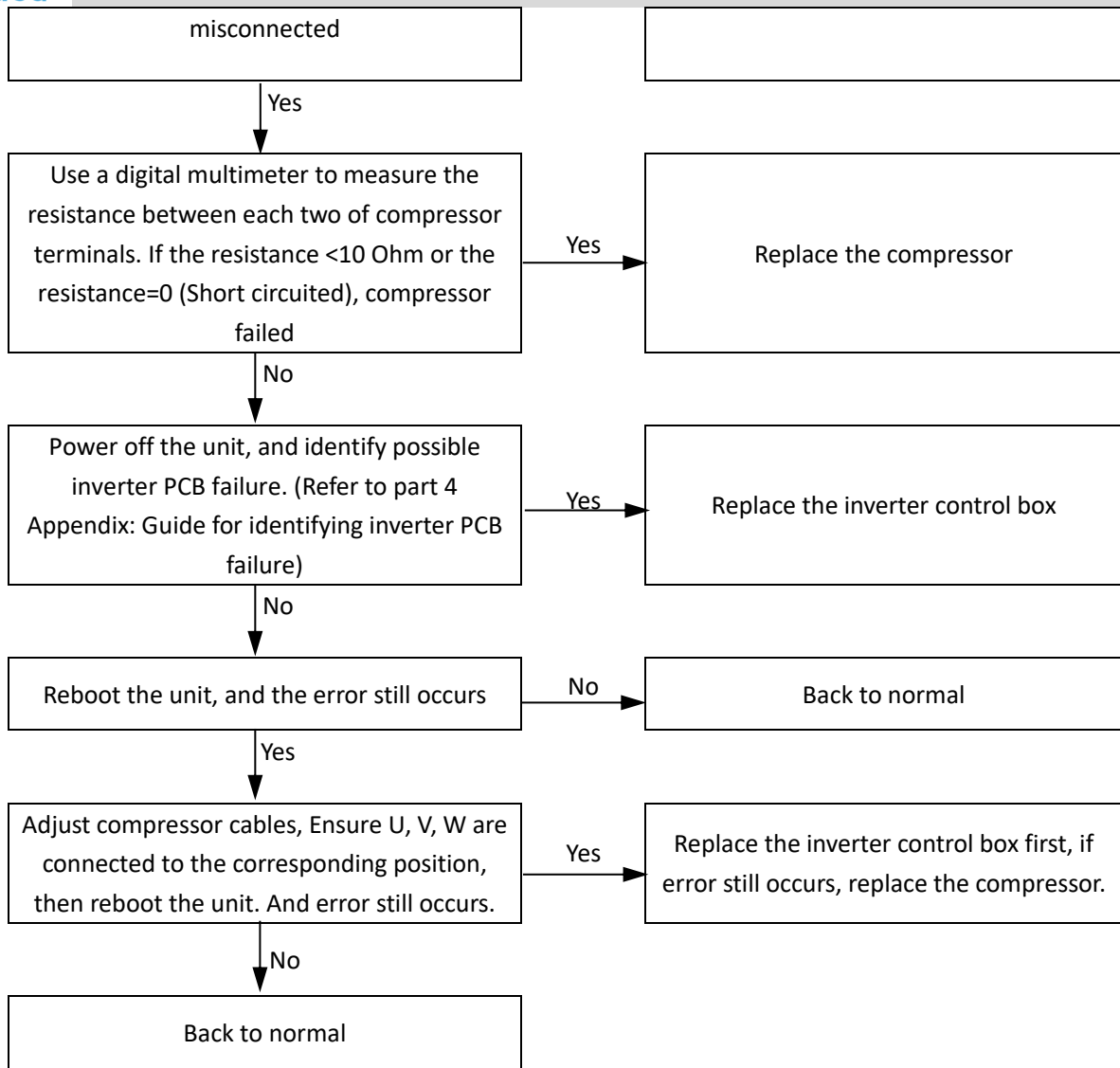

6.16 P4 Troubleshooting

6.16.1 Digital display output



6.16.2 Description

Error code		P4
Description		Compressor protection against excessively-high discharge temperature
Triggering		Main Control PCB detected that the compressor discharge temperature was $\geq 115^{\circ}\text{C}$
Relative ports and Locations	Tp discharge temp. sensor	
	Tw_in Tw_out	

6.16.3 Procedure

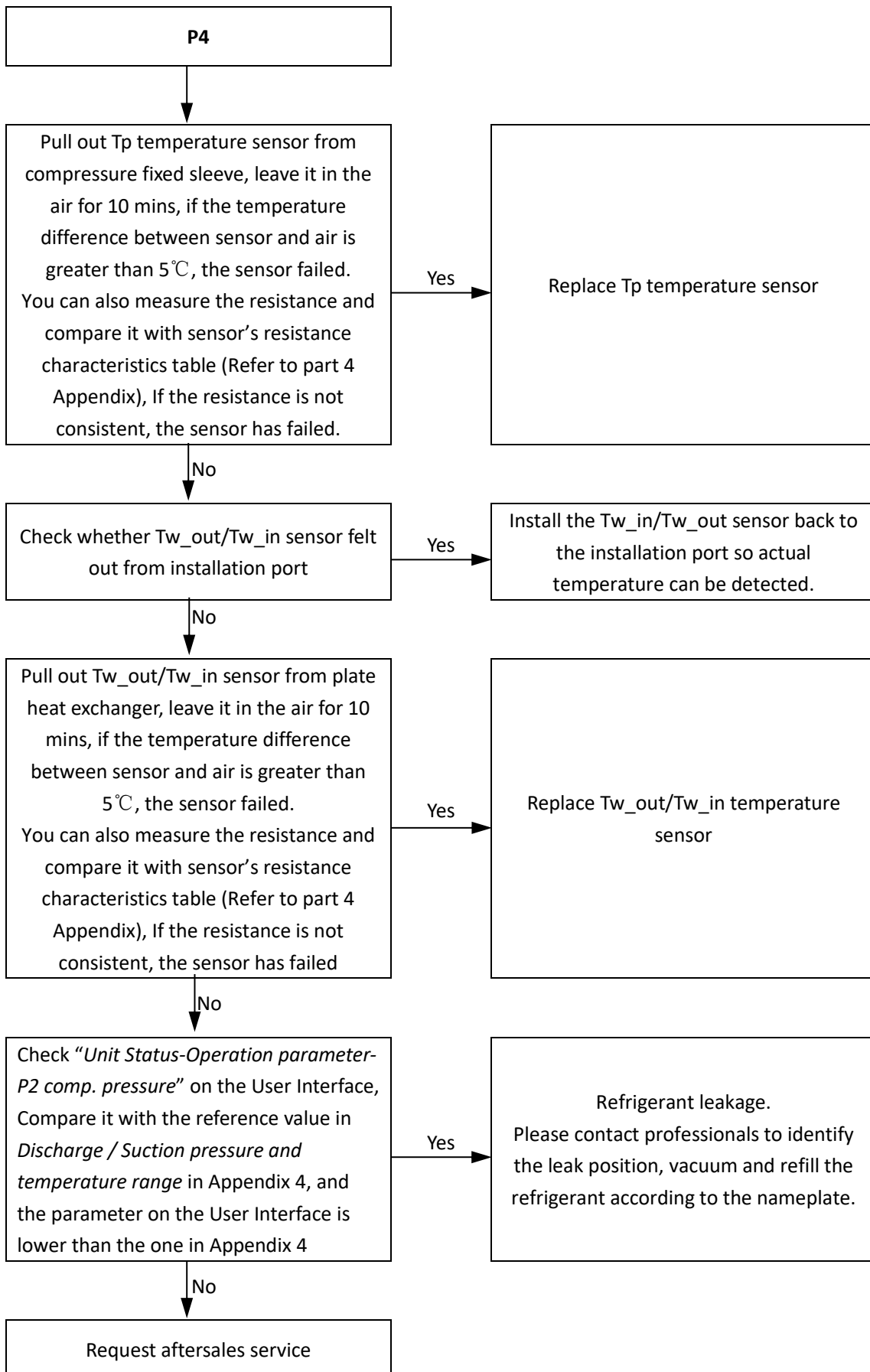

6.17 Pd Troubleshooting

6.17.1 Digital display output



6.17.2 Description

Error code	Pd
Description	Protection for excessively-high condensing temperature in cooling mode
Triggering	Main Control PCB detected that the condensing temperature was $\geq 65^{\circ}\text{C}$ in cooling mode
Relative ports and Locations	<p>The image shows two views of the main control PCB. The left view is a full view of the board with a digital display showing '888'. The right view is a close-up of the sensor connector area, showing a yellow connector labeled 'H-SEN' and a red connector labeled 'L-SEN'. Other components labeled include 'CN3', 'CN46', 'IC10', 'R200', and 'R345'.</p>

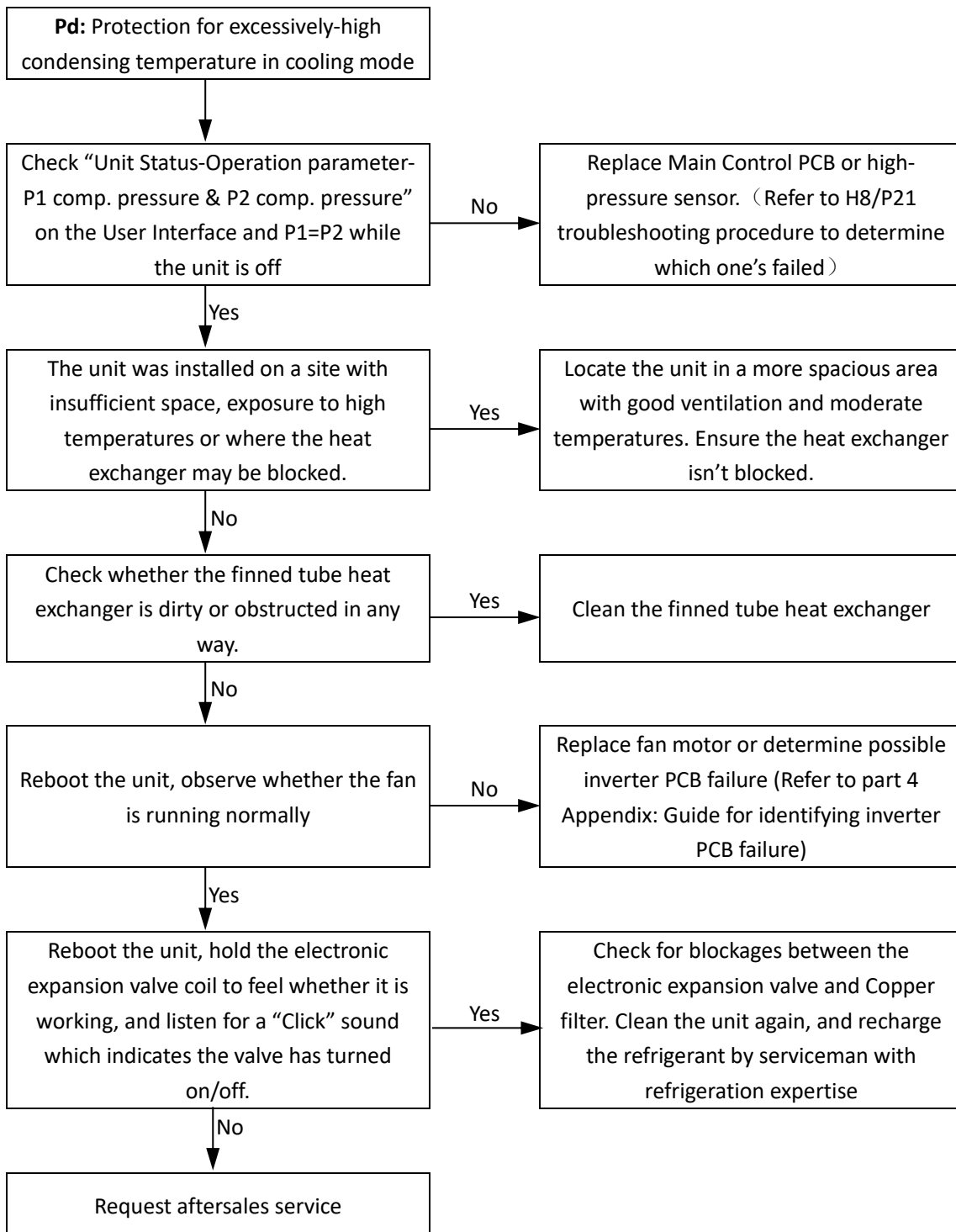
6.17.3 Procedure

6.18 HP Troubleshooting

6.18.1 Digital display output



6.18.2 Description

Error code	HP
Description	Low-pressure protection in cooling mode
Triggering	Main Control PCB detected that the suction pressure $P2 < 0.35\text{Mpa}$ for 5 seconds in cooling mode and compressor running over 300 seconds.
Tw_in Tw_out	

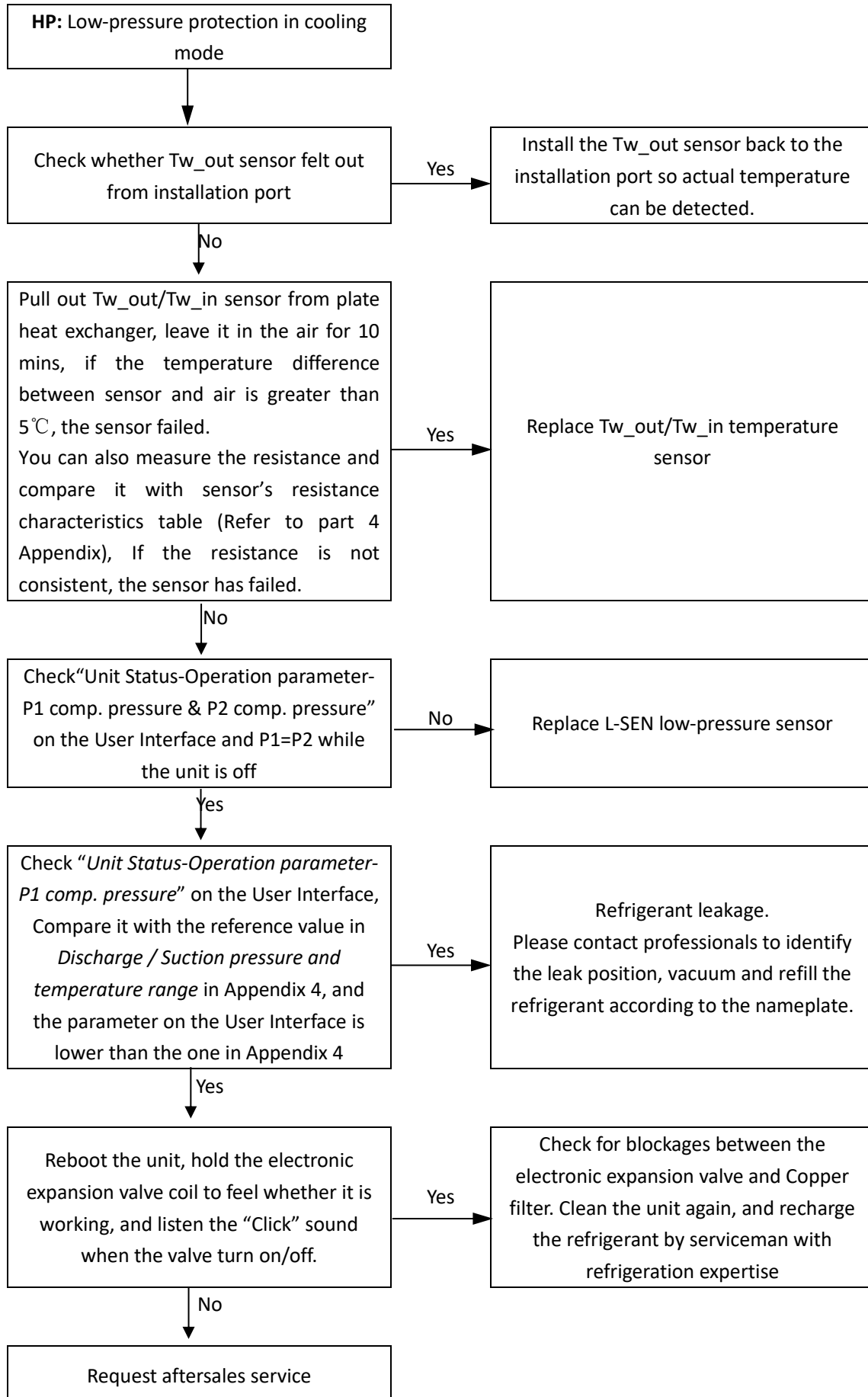
6.18.3 Procedure

6.19 bA Troubleshooting

6.19.1 Digital display output

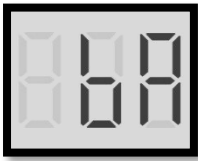

6.19.2 Description

Error code	bA
Description	T4 sensor out of operation range protection
Triggering	In heating/ DHW mode, the error occurs when $T4 \geq 65^{\circ}\text{C}$ or $T4 < -25^{\circ}\text{C}$ In cooling mode, the error occurs when $T4 \geq 65^{\circ}\text{C}$ or $T4 < -5^{\circ}\text{C}$
T4	A photograph showing a white plastic T4 sensor component mounted on a metal surface.

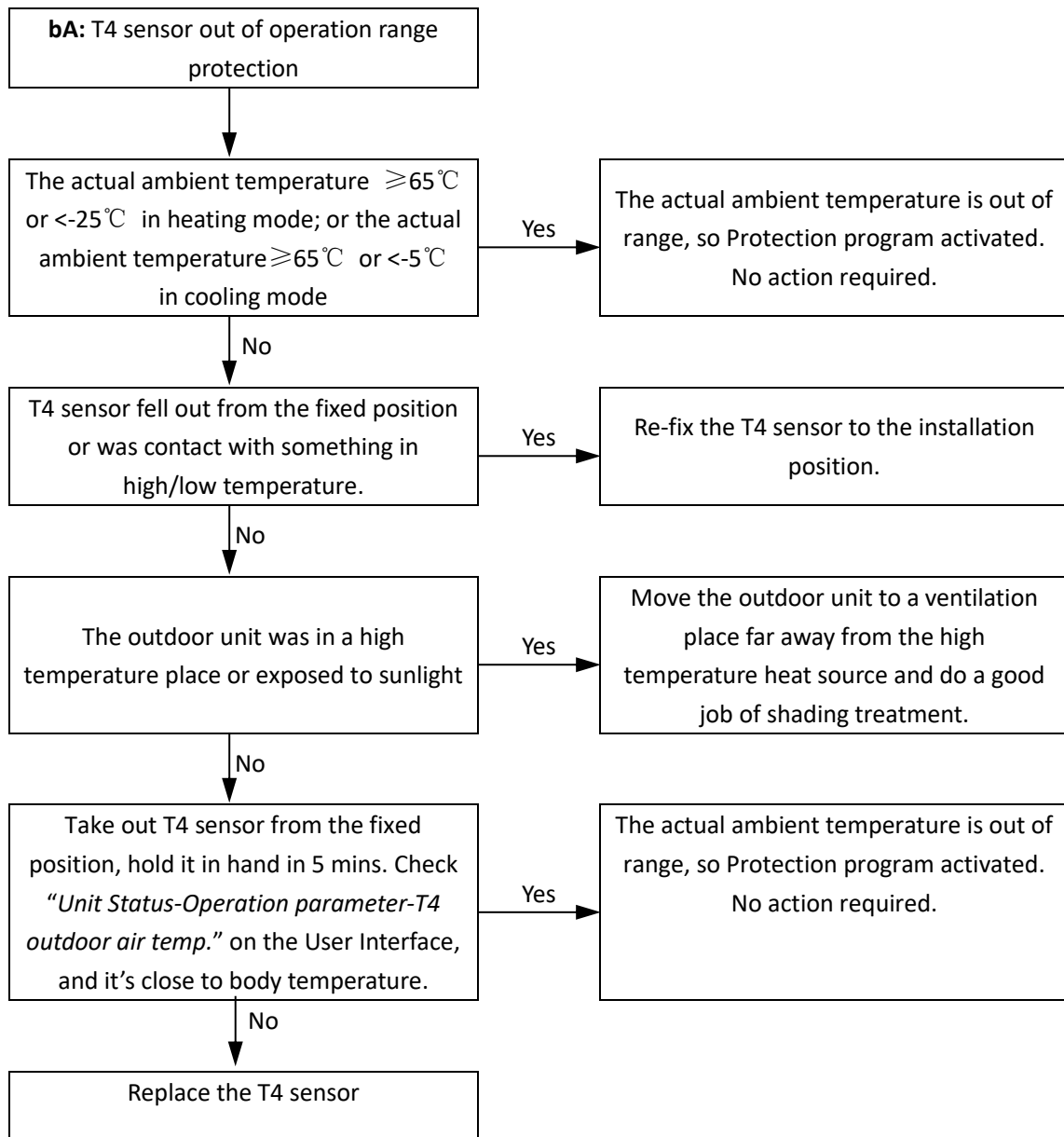
6.19.3 Procedure

6.20 PP, Hb Troubleshooting

6.20.1 Digital display output

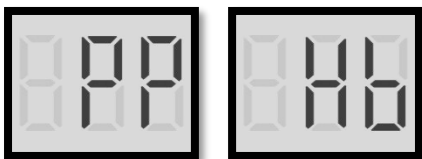

6.20.2 Description

Error code	PP	Hb
Description	Protection for abnormal temperature difference between outlet water and inlet water	PP occurs 3 times in heating/DHW mode
Triggering	$Tw_{out} - Tw_{in} \geq 3^{\circ}\text{C}$ and lasts 15 mins in cooling mode $Tw_{in} - Tw_{out} \geq 3^{\circ}\text{C}$ and lasts 15 mins in heating/DHW mode	PP occurs 3 times in heating/DHW mode; When $Tw_{out} < 7^{\circ}\text{C}$ occurs, the number of PP failures increases by one
Outlet pipe and inlet pipe		
Tw_in Tw_out		
CN71 ST1 Port for 4-way valve		
For-way valve E S C		

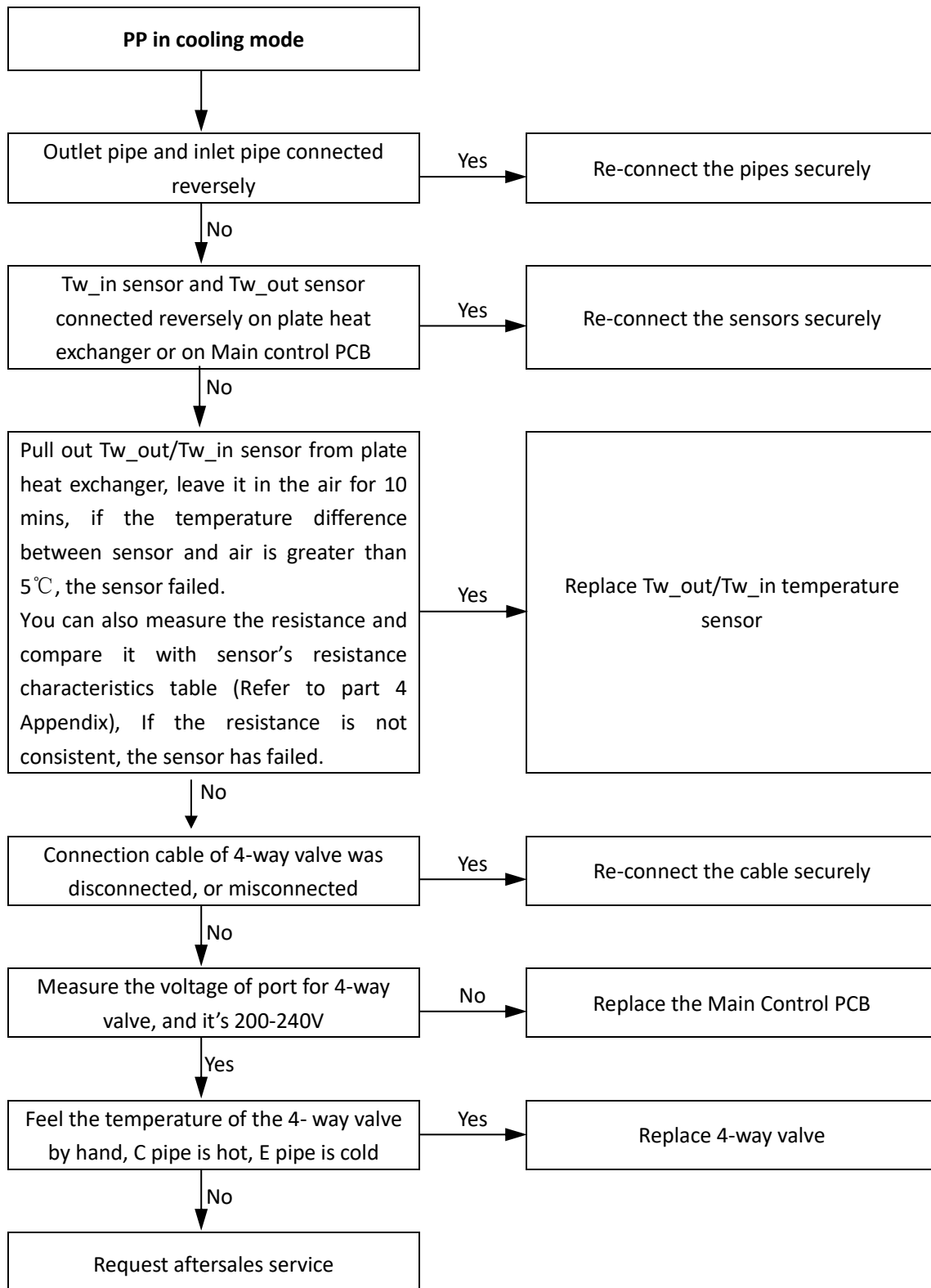
6.20.3 Procedure

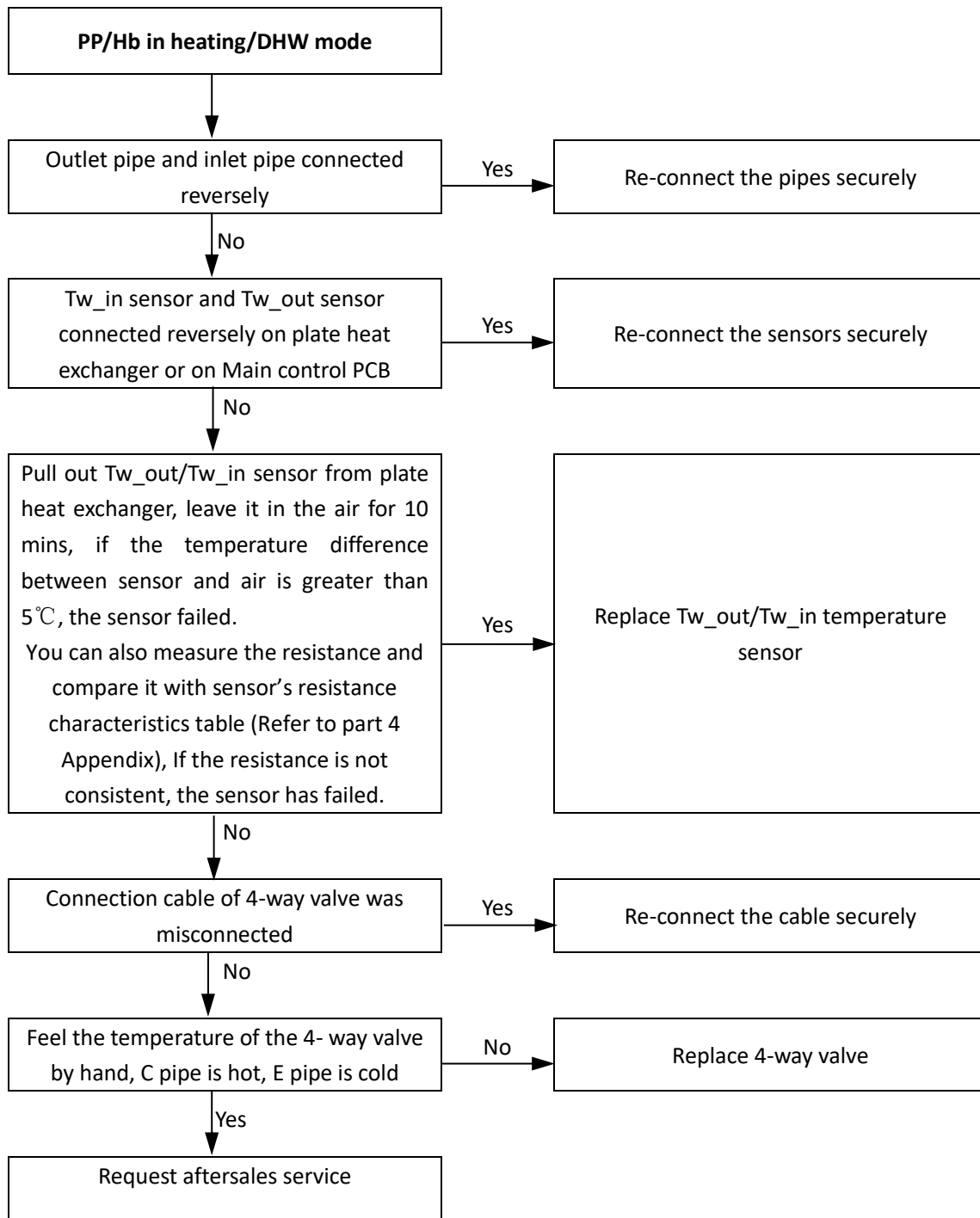

6.21 P5 Troubleshooting

6.21.1 Digital display output



6.21.2 Description

Error code	P5
Description	The big temperature difference between outlet water temp. and inlet water temp.
Triggering	$Tw_{out}-Tw_{in} \geq 30^{\circ}\text{C}$ in heating/DHW mode $Tw_{out}-Tw_{in} \geq 17^{\circ}\text{C}$ in cooling mode
Tw_in Tw_out	

6.21.3 Procedure

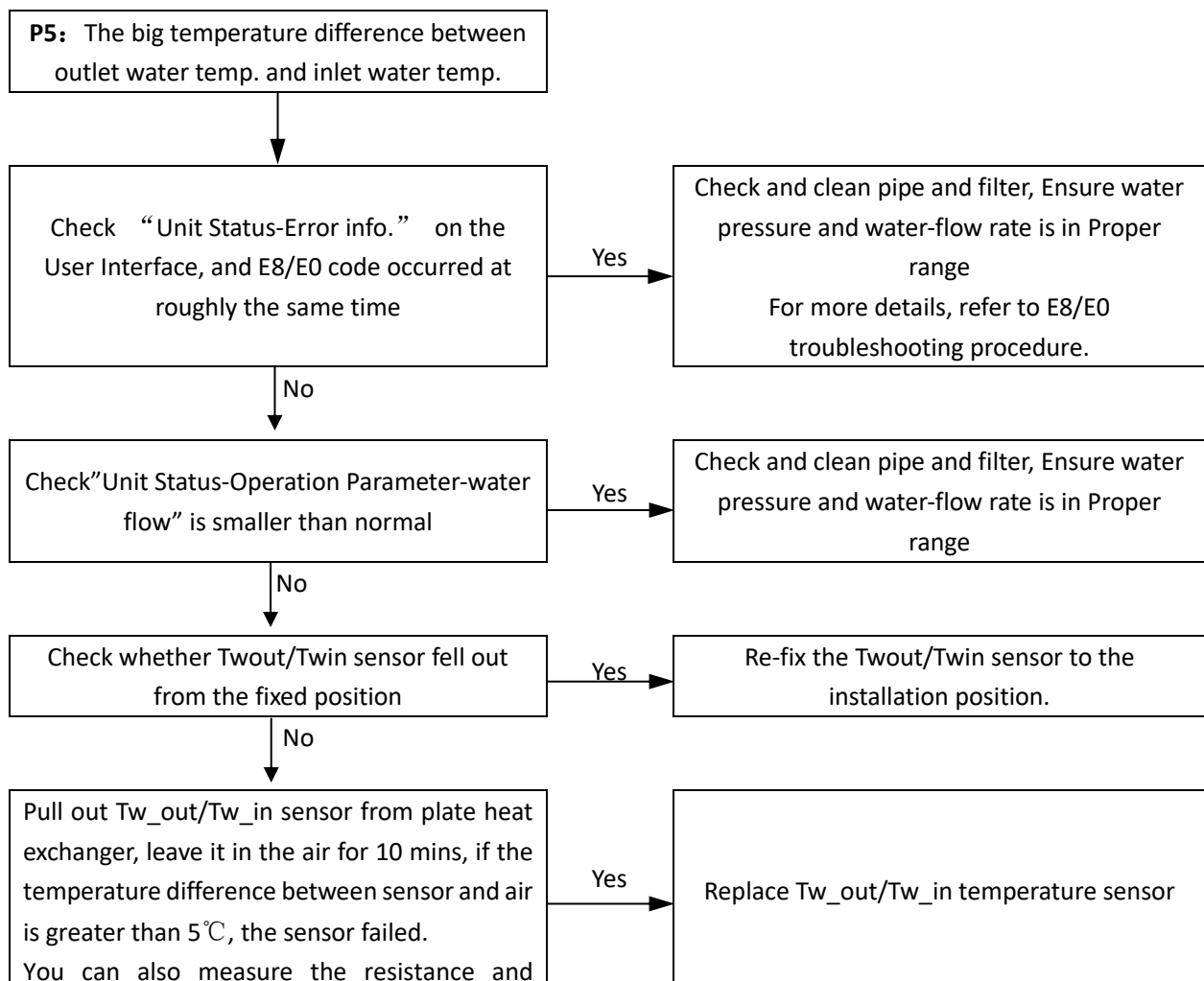

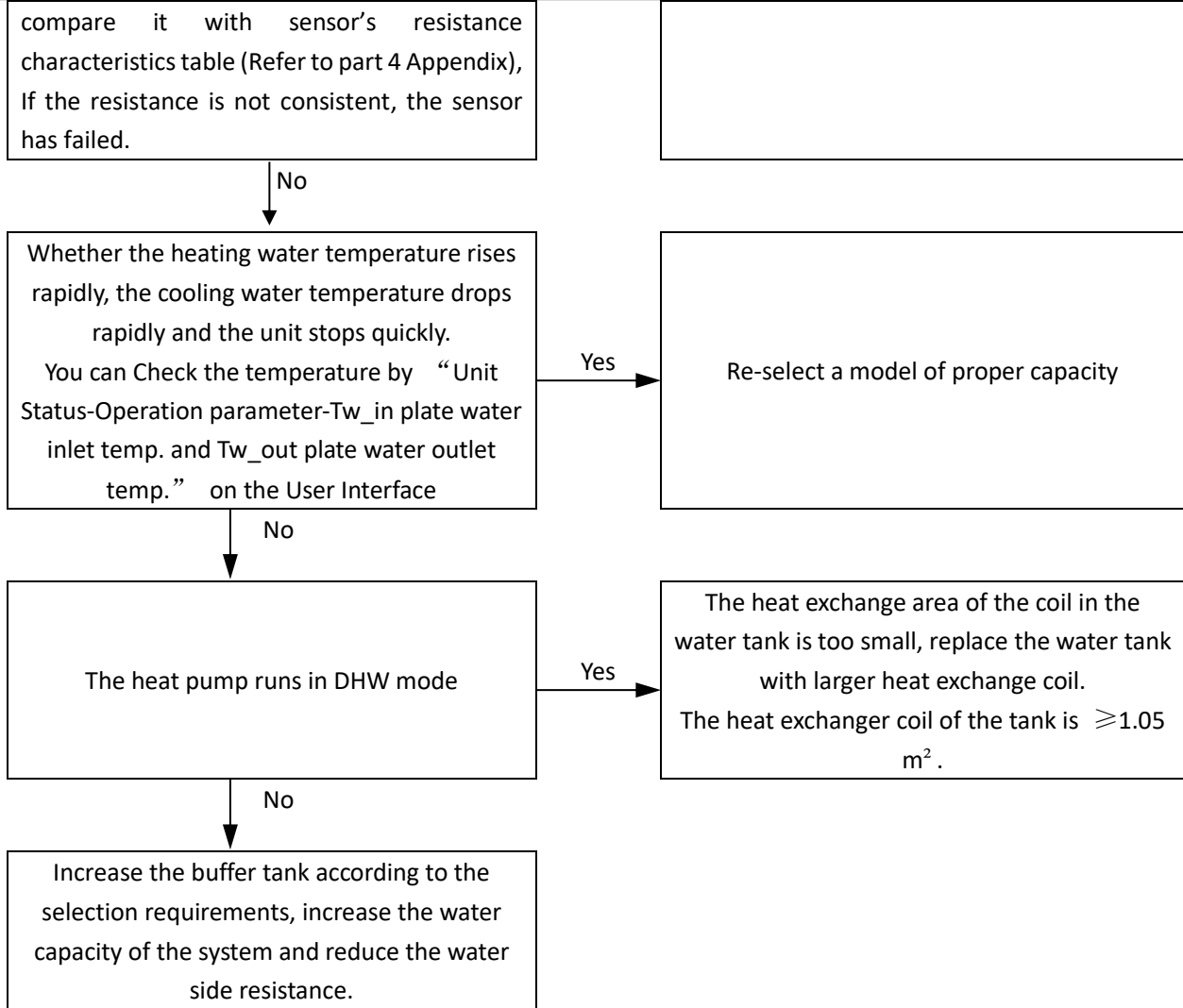

6.22 F75 Troubleshooting

6.22.1 Digital display output



6.22.2 Description

Error code	F75																												
Description	Protection for insufficient discharge overheating degree.																												
Triggering	$T_p - T_c < 0^\circ\text{C}$ and last 10 mins																												
Tp discharge temp. sensor																													
Nameplate	<table border="1"> <thead> <tr> <th colspan="2">MONOBLOC HEAT PUMP</th> </tr> </thead> <tbody> <tr> <td>MODEL</td> <td>MHC-V8WD2N7-B</td> </tr> <tr> <td>COOLING CAPACITY/EEER @ A35W18</td> <td>8.30kW/5.25</td> </tr> <tr> <td>HEATING CAPACITY/COP @ A7W35</td> <td>8.00kW/5.25</td> </tr> <tr> <td>POWER SOURCE</td> <td>220-240V - 50Hz</td> </tr> <tr> <td>RATED INPUT</td> <td>3900W</td> </tr> <tr> <td>RATED WATER PRESSURE</td> <td>0.1-0.3MPa</td> </tr> <tr> <td>NET WEIGHT</td> <td>148kg</td> </tr> <tr> <td>REFRIGERANT</td> <td>R290/1100g</td> </tr> <tr> <td>GWP</td> <td>3</td> </tr> <tr> <td>EQUIVALENT CO₂</td> <td>0.0033t</td> </tr> <tr> <td>EXCESSIVE OPERATING PRESSURE</td> <td>3.5MPa</td> </tr> <tr> <td>MAXIMUM ALLOWABLE PRESSURE</td> <td>3.5MPa</td> </tr> <tr> <td>OUTDOOR RESISTANCE CLASS</td> <td>IP24</td> </tr> </tbody> </table> <p>Refer to Nameplate for rated refrigerant charge volume. The picture is for reference only. The actual product may vary.</p>	MONOBLOC HEAT PUMP		MODEL	MHC-V8WD2N7-B	COOLING CAPACITY/EEER @ A35W18	8.30kW/5.25	HEATING CAPACITY/COP @ A7W35	8.00kW/5.25	POWER SOURCE	220-240V - 50Hz	RATED INPUT	3900W	RATED WATER PRESSURE	0.1-0.3MPa	NET WEIGHT	148kg	REFRIGERANT	R290/1100g	GWP	3	EQUIVALENT CO ₂	0.0033t	EXCESSIVE OPERATING PRESSURE	3.5MPa	MAXIMUM ALLOWABLE PRESSURE	3.5MPa	OUTDOOR RESISTANCE CLASS	IP24
MONOBLOC HEAT PUMP																													
MODEL	MHC-V8WD2N7-B																												
COOLING CAPACITY/EEER @ A35W18	8.30kW/5.25																												
HEATING CAPACITY/COP @ A7W35	8.00kW/5.25																												
POWER SOURCE	220-240V - 50Hz																												
RATED INPUT	3900W																												
RATED WATER PRESSURE	0.1-0.3MPa																												
NET WEIGHT	148kg																												
REFRIGERANT	R290/1100g																												
GWP	3																												
EQUIVALENT CO ₂	0.0033t																												
EXCESSIVE OPERATING PRESSURE	3.5MPa																												
MAXIMUM ALLOWABLE PRESSURE	3.5MPa																												
OUTDOOR RESISTANCE CLASS	IP24																												

6.22.3 Procedure

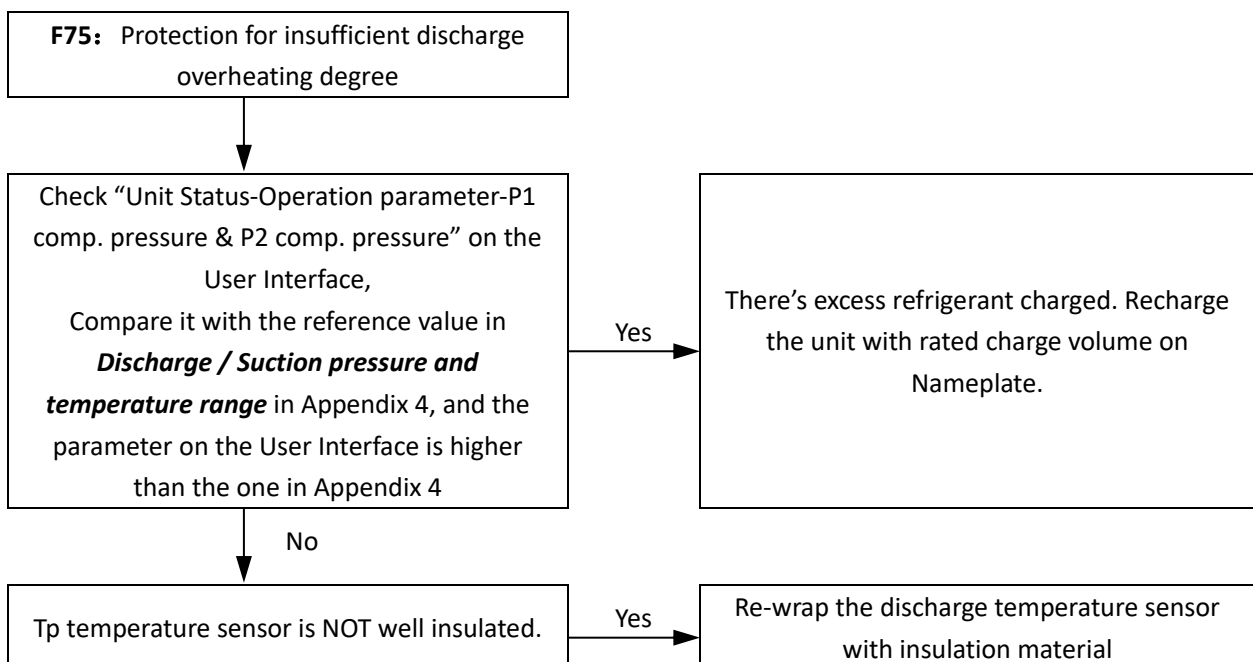

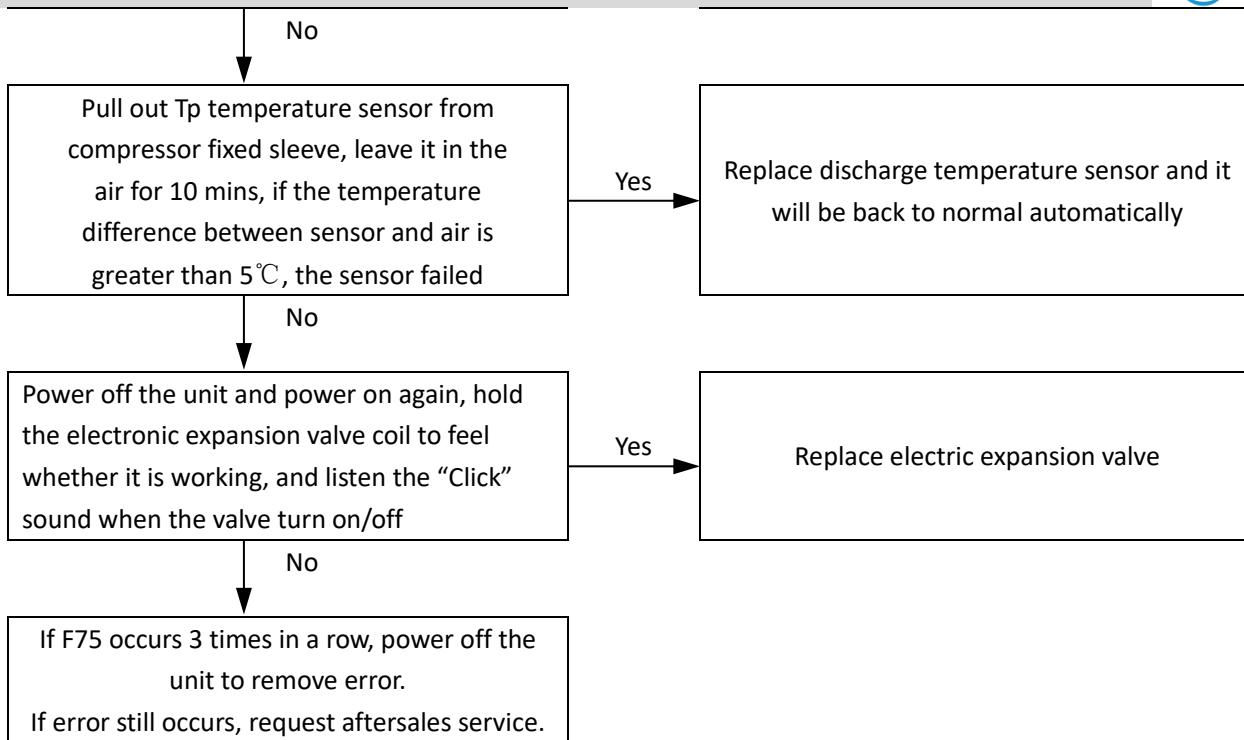

6.23 F1 Troubleshooting

6.23.1 Digital display output

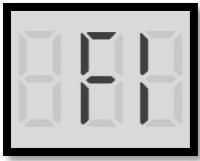

6.23.2 Description

Error code	F1
Description	Protection for DC bus undervoltage
Triggering	For single phase inverter PCB, the DC bus voltage $\leq 200\text{VDC}$
<p>BUS voltage(P-N) (Inverter PCB)</p>	

6.23.3 Procedure

For single phase:

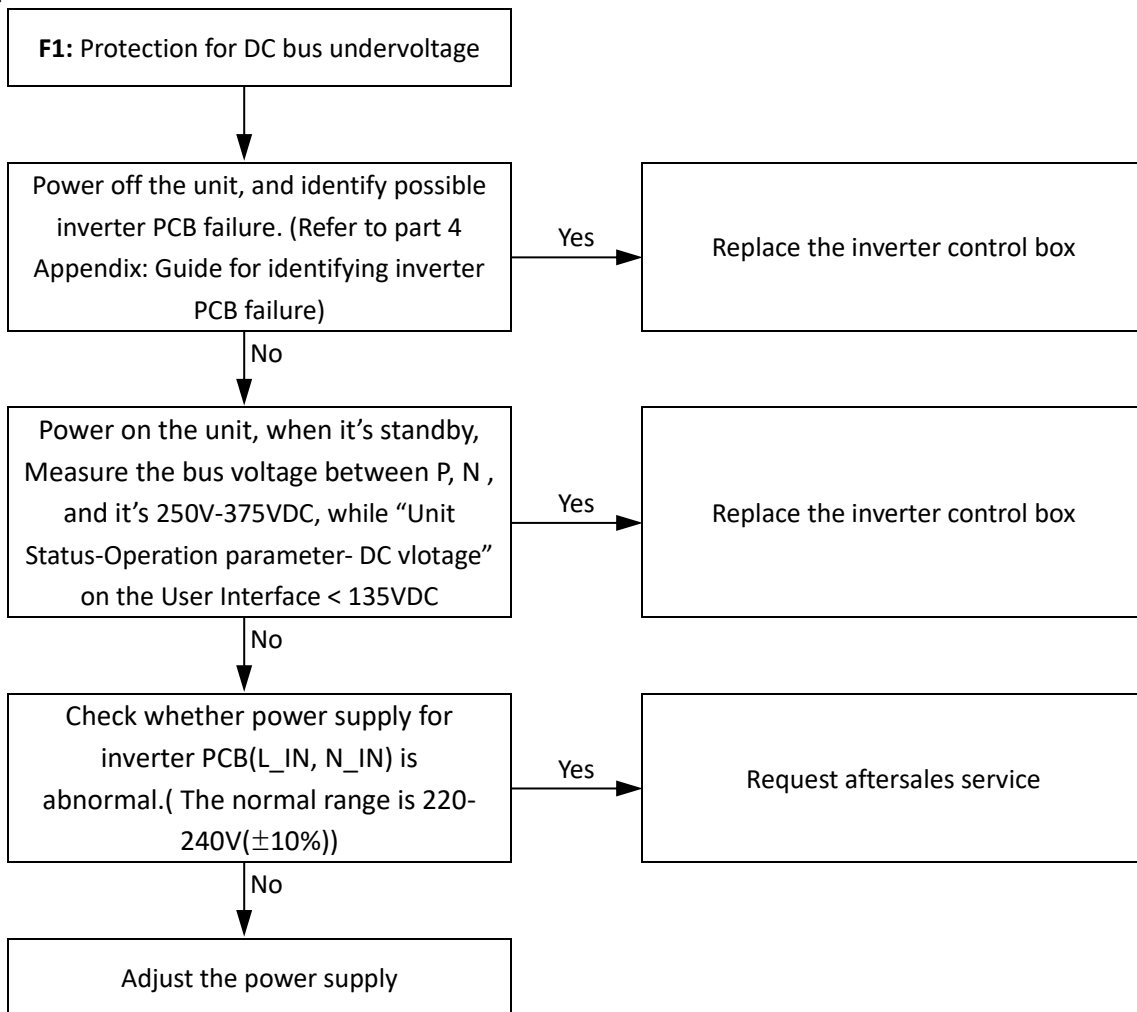

6.24 C7 Troubleshooting

6.24.1 Description

Error code	C7
Description	Excessively-high temperature protection for IPM module
Triggering	IPM module temperature $\geq 95^{\circ}\text{C}$

6.24.2 Digital display output



6.24.3 Procedure

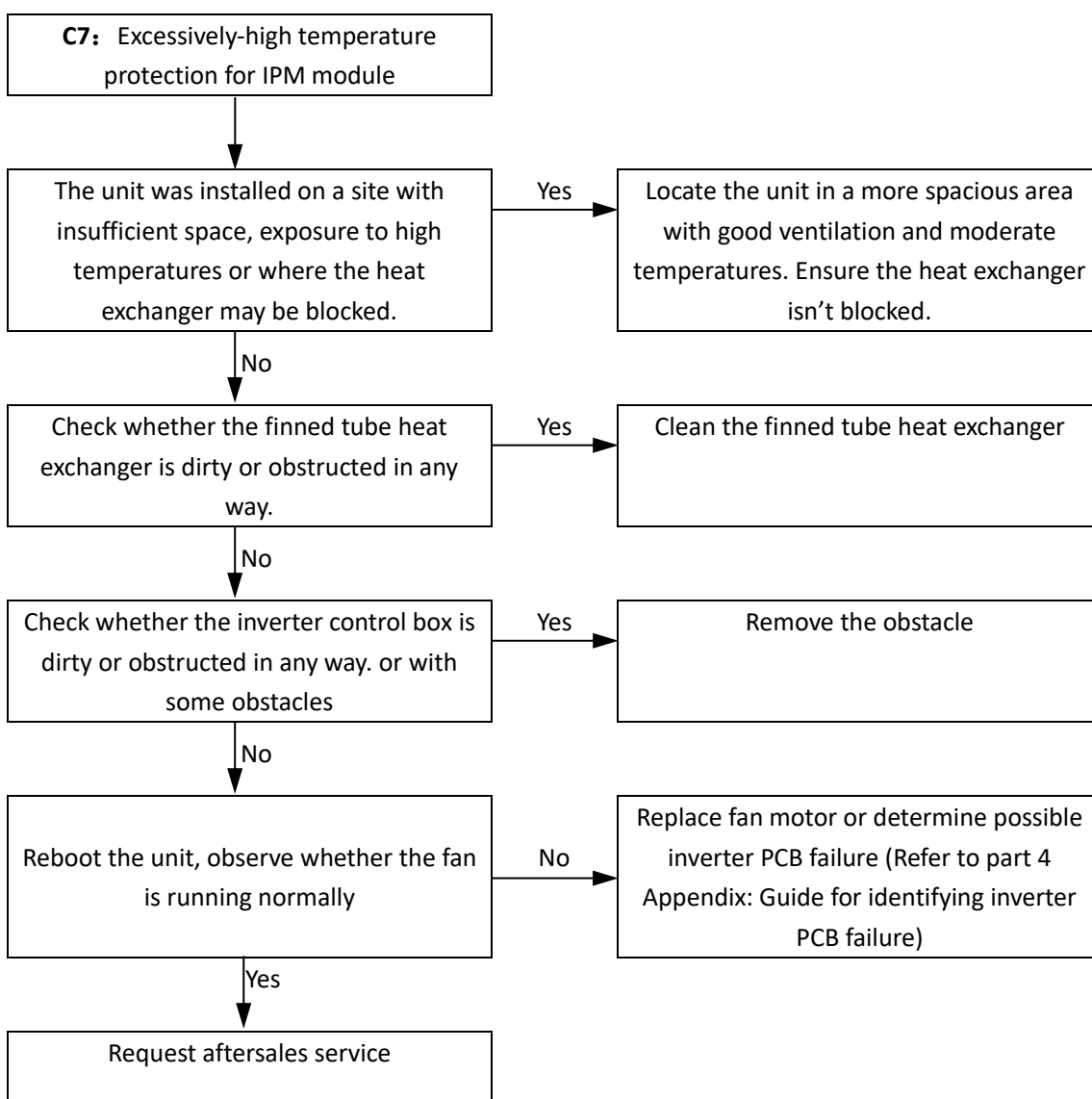

6.25 H4, L** Troubleshooting

6.25.1 Digital display output

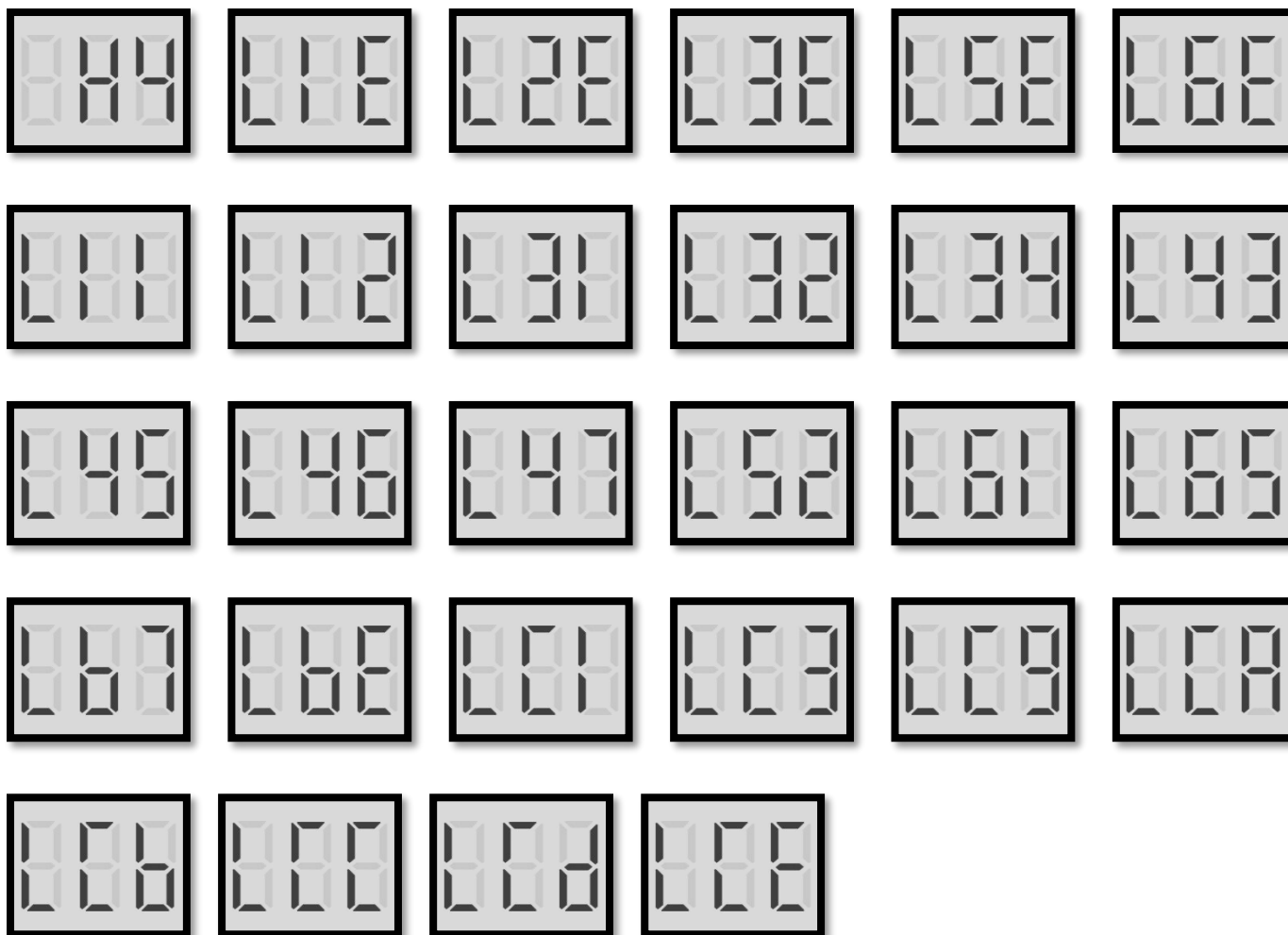

6.25.2 Description

Error code	Description	Note
H4	3 times of "L1*" in 60 mins	
L**	Inverter module protection	Check the specific code on digital display panel on the Main Control PCB

The specific L** code table:

Error code	Description	Note
L1E	Hardware overcurrent protection	
L11	Phase current instantaneous overcurrent protection	
L12	Phase current continuous 30s overcurrent protection	
L2E	Over-temperature protection	
L3E	Bus voltage too low error	
L31	Bus voltage too high error	
L32	Bus voltage excessively high error	
L34	Phase loss error of three-phase power supply	For 3Ph units
L43	Abnormal phase current sampling bias	
L45	Fan motor code mismatch error	
L46	IPM protection (FO)	

L47	Module type mismatch	
L5E	Motor failed to start	
L52	Motor stalling protection	
L6E	Phase loss protection	
L61	Compressor terminals short circuit protection	
L65	IPM short circuit protection	
LBE	Action of high-pressure switch	
LB7	PED bH error	
LCE	PFC HARDWARE OVERCURRENT PROTECTION	For 3Ph units
LC1	Instantaneous overcurrent of PFC software protection	For 3Ph units
LC3	PFC low voltage protection	For 3Ph units
LC9	Over-temperature protection of PFC module	For 3Ph units
LCA	PFC module CBC overcurrent error protection	For 3Ph units
LCB	Overvoltage of PFC bus or PFC half bus	For 3Ph units
LCC	Short circuit of PFC IGBT	For 3Ph units
LCD	Abnormal PFC Ad sampling bias	For 3Ph units

6.25.3 Procedure

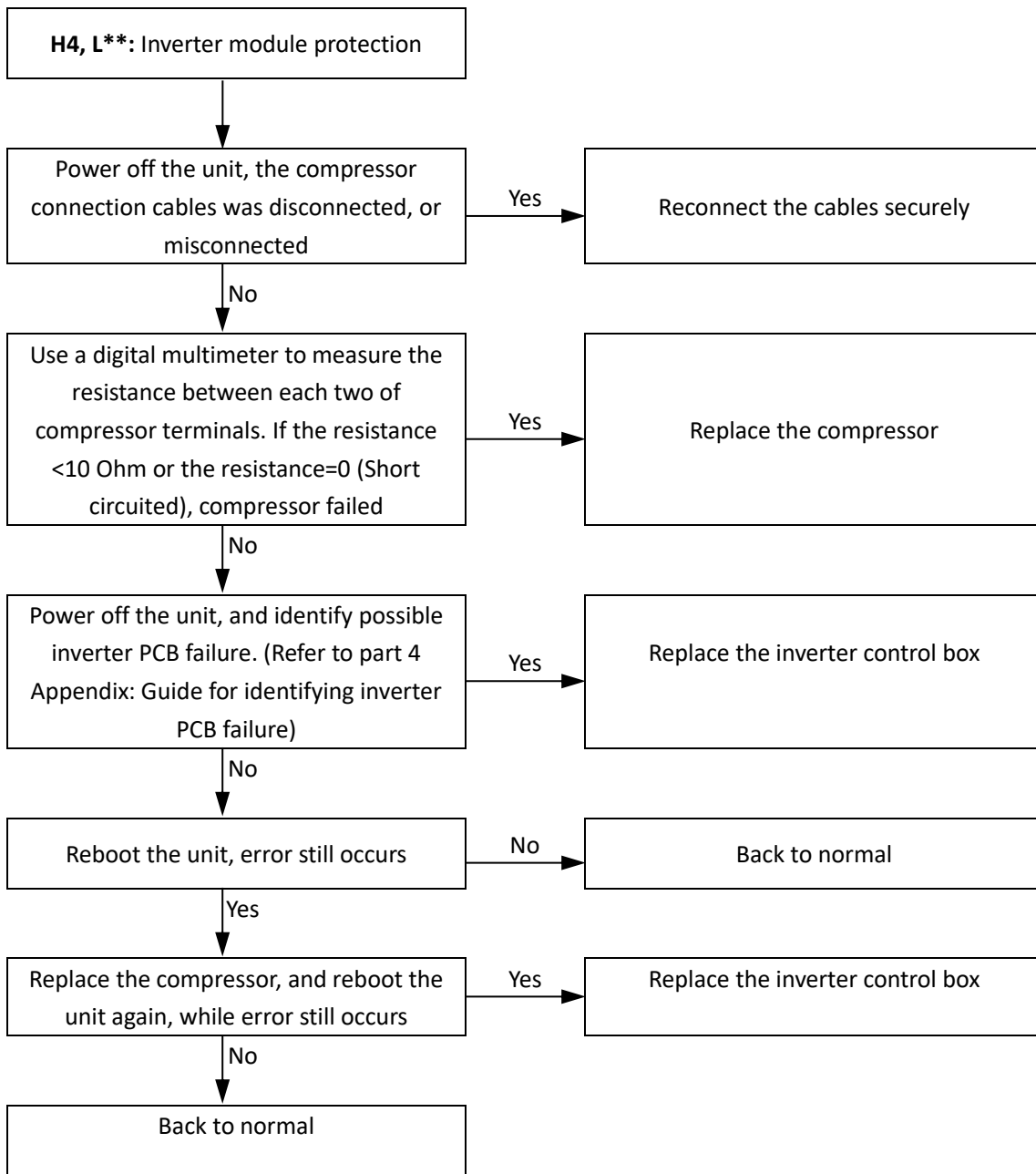

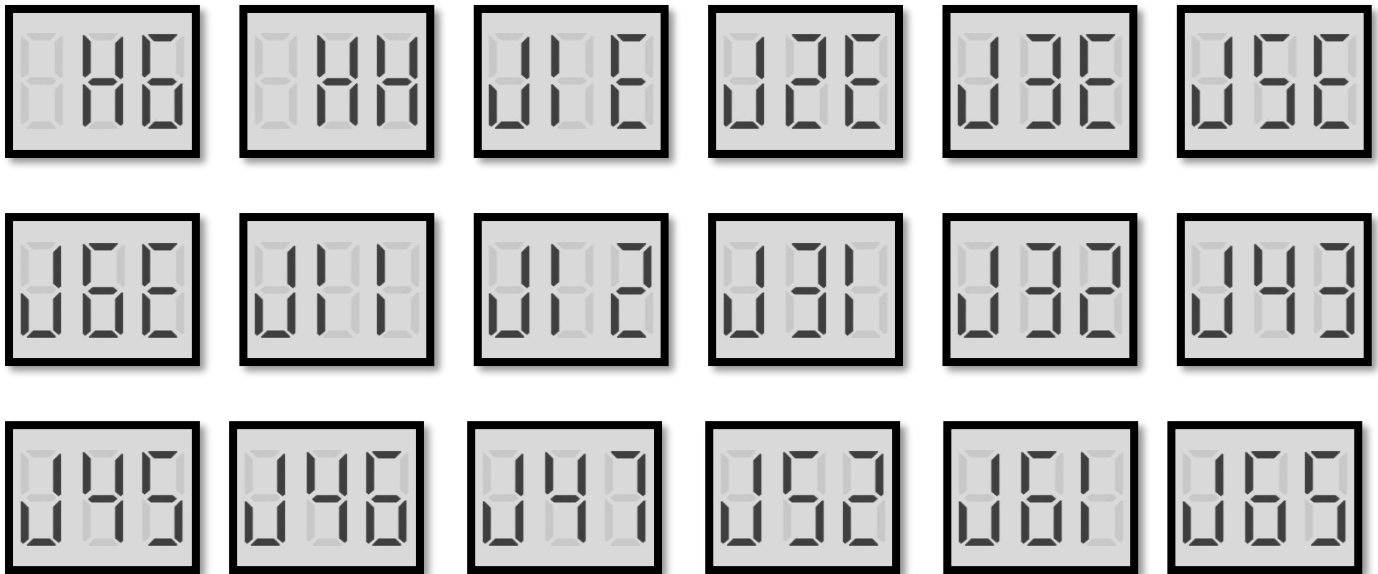
6.26 H6, HH, J Troubleshooting**
6.26.1 Digital display output

6.26.2 Description

Error code	Description	Note
H6	Fan failure	/
HH	10 times of H6 in 120mins	/
J**	Fan module failure	Check the specific code on digital display panel on the Main Control PCB

The specific J** code table:

Error code	Description
J1E	Hardware overcurrent protection
J11	Phase current instantaneous overcurrent protection
J12	Phase current continuous 30s overcurrent protection
J2E	Over-temperature protection
J3E	Bus voltage too low error
J31	Bus voltage too high error
J32	Bus voltage excessively high error
J43	Abnormal phase current sampling bias
J45	Fan motor code mismatch error
J46	IPM protection (FO)
J47	Module type mismatch (after module resistance tested)
J5E	Motor failed to start
J52	Motor stalling protection
J6E	Phase loss protection
J61	Fan terminals short circuit protection
J65	IPM short circuit protection

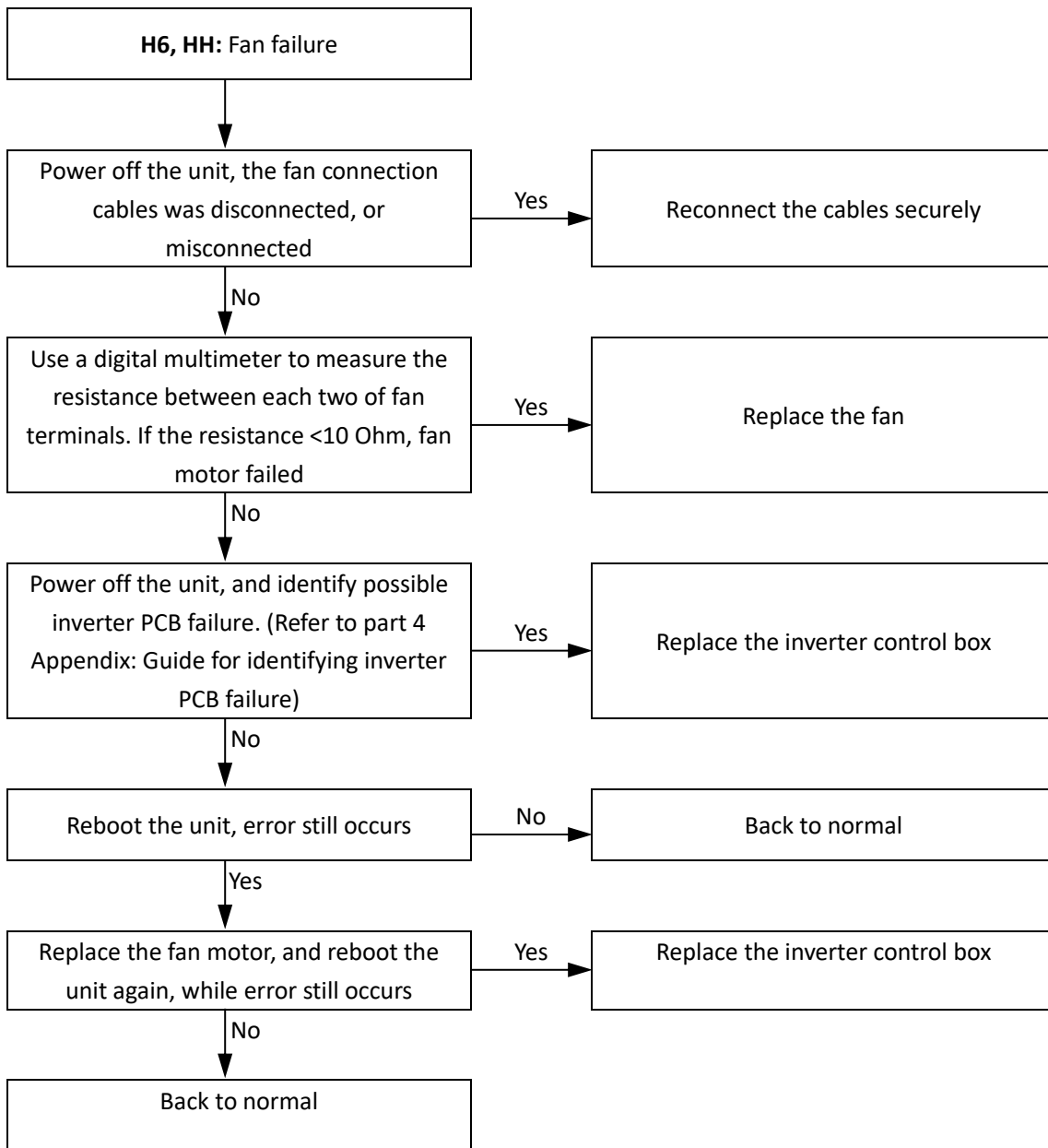
6.26.3 Procedure



6.27 HF Troubleshooting

6.27.1 Digital display output



6.27.2 Description

Error code		HF
Description		Outdoor unit EEPROM error
Triggering		The driving program of inverter PCB is detected as being mismatched with Dip switch
Relative ports and Locations	Dip switch S5 S6	
Correct Dip switch	S5	series N:1/0/0/0
	S6 (8-16kW 1Ph)	0/0/1/1-8kW、0/1/0/0-10kW、0/1/0/1-12kW、0/1/1/0-14kW、0/1/1/1-16kW
	S6 (8-16kW 3Ph)	1/0/1/1-8kW、1/1/0/0-10kW、1/1/0/1-12kW、1/1/1/0-14kW、1/1/1/1-16kW

6.27.3 Procedure

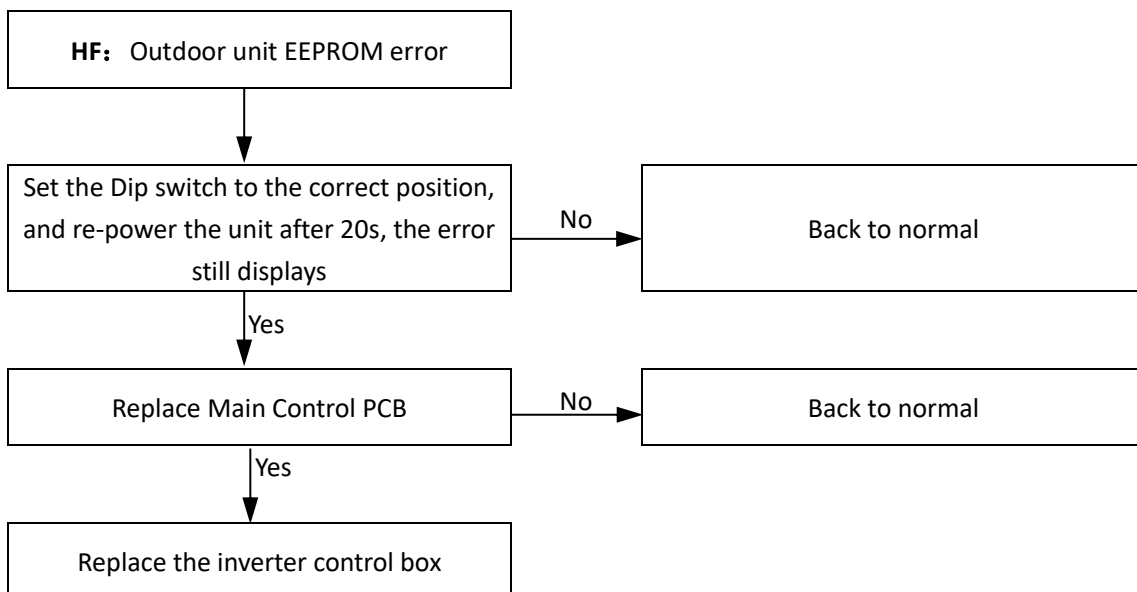

6.28 Pb Troubleshooting

6.28.1 Digital display output



6.28.2 Description

Error code	Pb
Description	Pb is the indicator that shows the system is running in anti-freezing control
Triggering	Refer to Part 3 - Protection control – Anti-freezing protection control
User Interface	<p>It shows anti-freezing icon on the User Interface</p>

6.29 C2 Troubleshooting

6.29.1 Digital display output

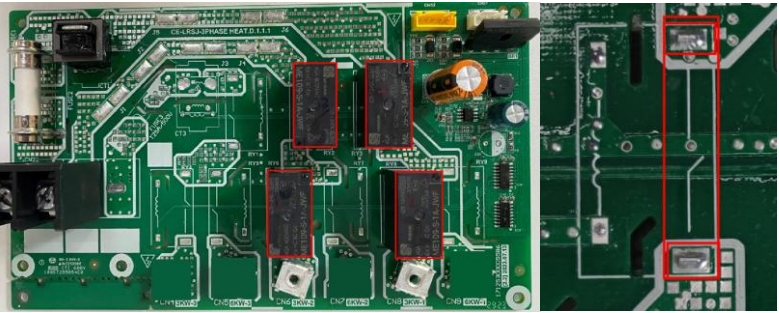

6.29.2 Description

Error code		C2
Description		Relay adhesion on IBH PCB error
Triggering		Relay: Poor contact, relay deformation, relay aging, etc. External factors : overcurrent, over high ambient temperature, etc.
Relative ports and Locations	Relays and pins of a relay	
	User interface -For Serviceman- C2 restore	<div style="display: flex; justify-content: space-around;"> <div style="border: 1px solid gray; padding: 5px; width: 45%;"> <p style="text-align: center;">For serviceman</p> <p>HMI address setting > </p> <p>Common setting ></p> <p>C2 fault restore ></p> </div> <div style="border: 1px solid gray; padding: 5px; width: 45%;"> <p style="text-align: center;">For serviceman</p> <div style="border: 1px solid gray; padding: 5px; margin-bottom: 5px;"> <p>C2 Fault will berestored. Please confirm IBH PCB has been repaired.</p> </div> <p style="text-align: center;">NO YES</p> </div> </div>

6.29.3 Procedure

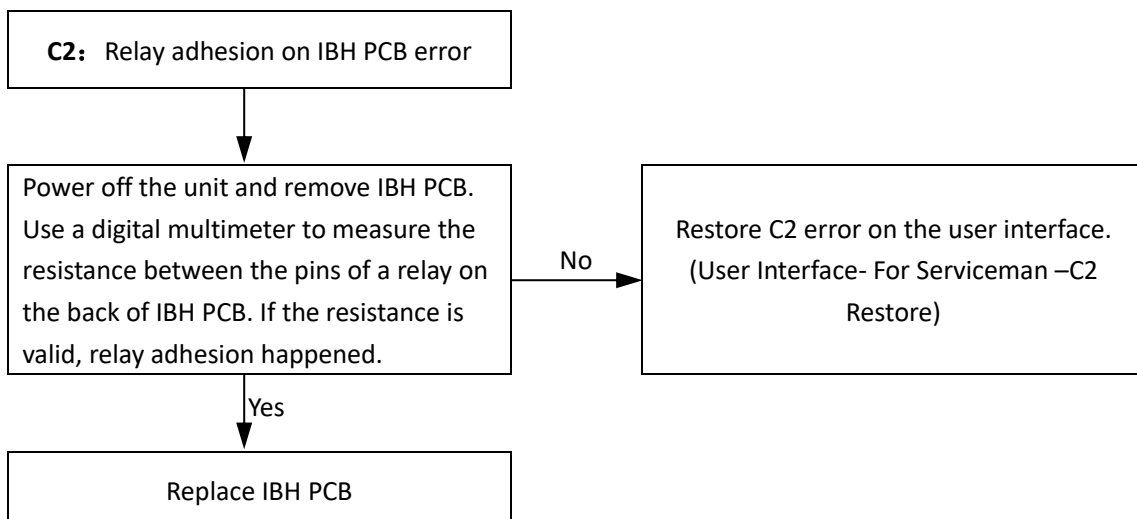

6.30 C3, C4 Troubleshooting

6.30.1 Digital display output

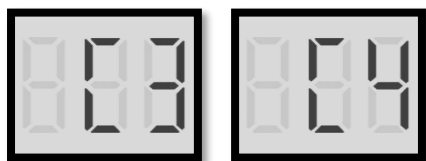

6.30.2 Description

Error code	C3	C4						
Description	Current transformer failure or circuit failure of IBH PCB	C3 ≥ 3 times						
Triggering	Incorrect Dip switch S1, cables with IBH connected improperly; Overvoltage, IBH failure etc.							
Correct Dip switch S1	<p style="text-align: center;">FACTORY SETTINGS</p> <table border="1" style="margin: auto;"> <tr> <td style="text-align: center;">3kW</td> <td style="text-align: center;">6kW</td> <td style="text-align: center;">9kW</td> </tr> <tr> <td style="text-align: center;"> </td> <td style="text-align: center;"> </td> <td style="text-align: center;"> </td> </tr> </table>		3kW	6kW	9kW			
3kW	6kW	9kW						
IBH PCB LED light								
Temperature controller								
Power transformer And "TRANS OUT" port								

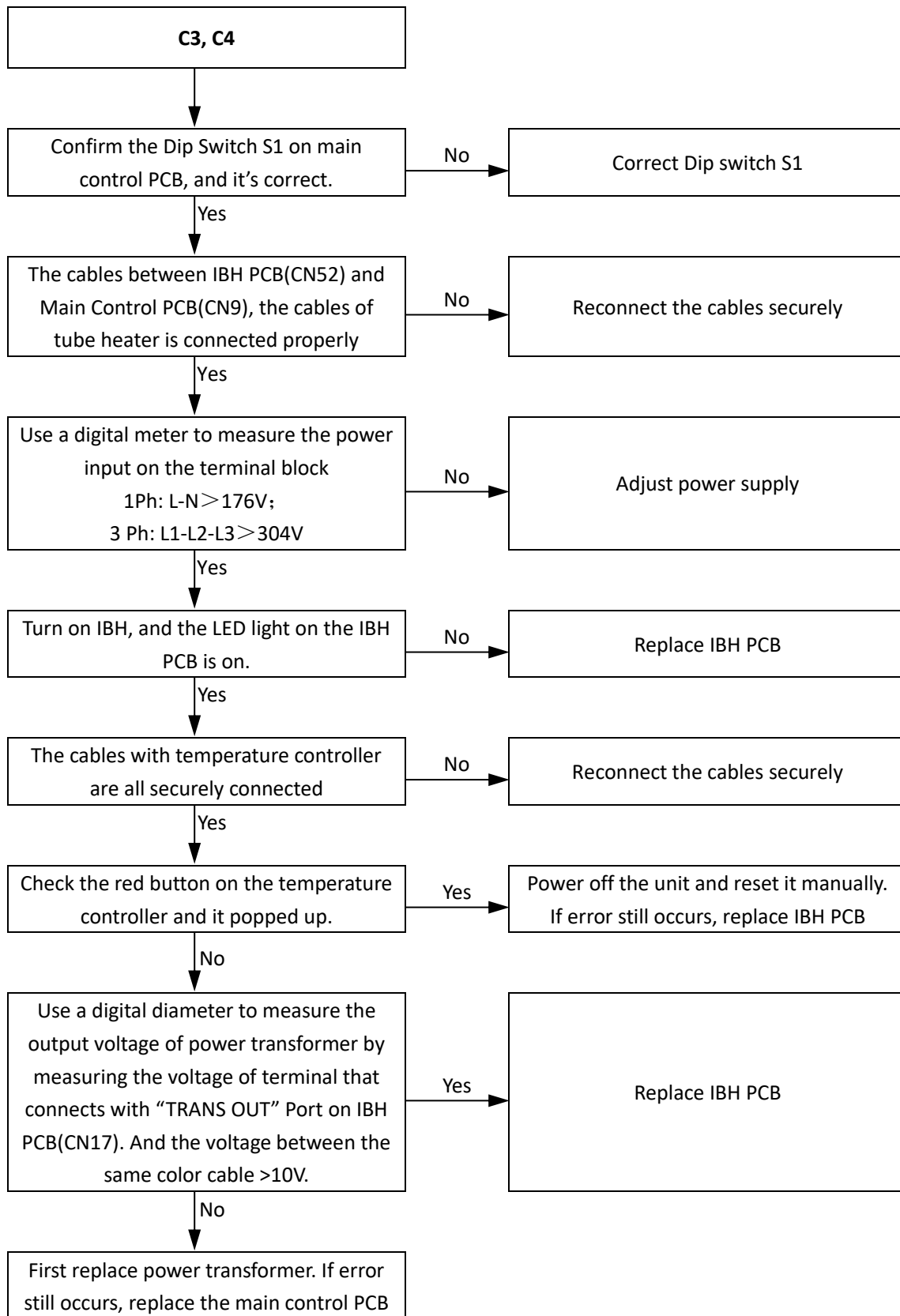
6.30.3 Procedure

6.31 A1, A2* Troubleshooting

6.31.1 Digital display output

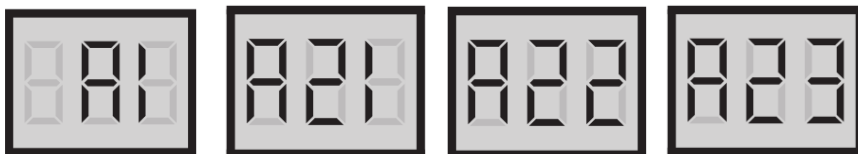

6.31.2 Description

Error code	Description
A1	The refrigerant leakage detected.
Triggering	Refrigerant sensor detected R290 concentration exceeds 10% <div style="text-align: center;"> <p>R290 refrigerant gas sensor</p> <p>8-16 kW unit with a backup heater(optional) 8-16 kW unit without a backup heater</p> </div>
A21	The refrigerant sensor malfunction.
Triggering	The refrigerant sensor module circuit failure
A22	The refrigerant sensor communication fault.
Triggering	The refrigerant sensor cannot communication with hydronic PCB CN36
A23	The refrigerant sensor ends of life fault.
Triggering	The refrigerant sensor's accumulated operation time exceeds 15 years.

6.31.3 Procedure

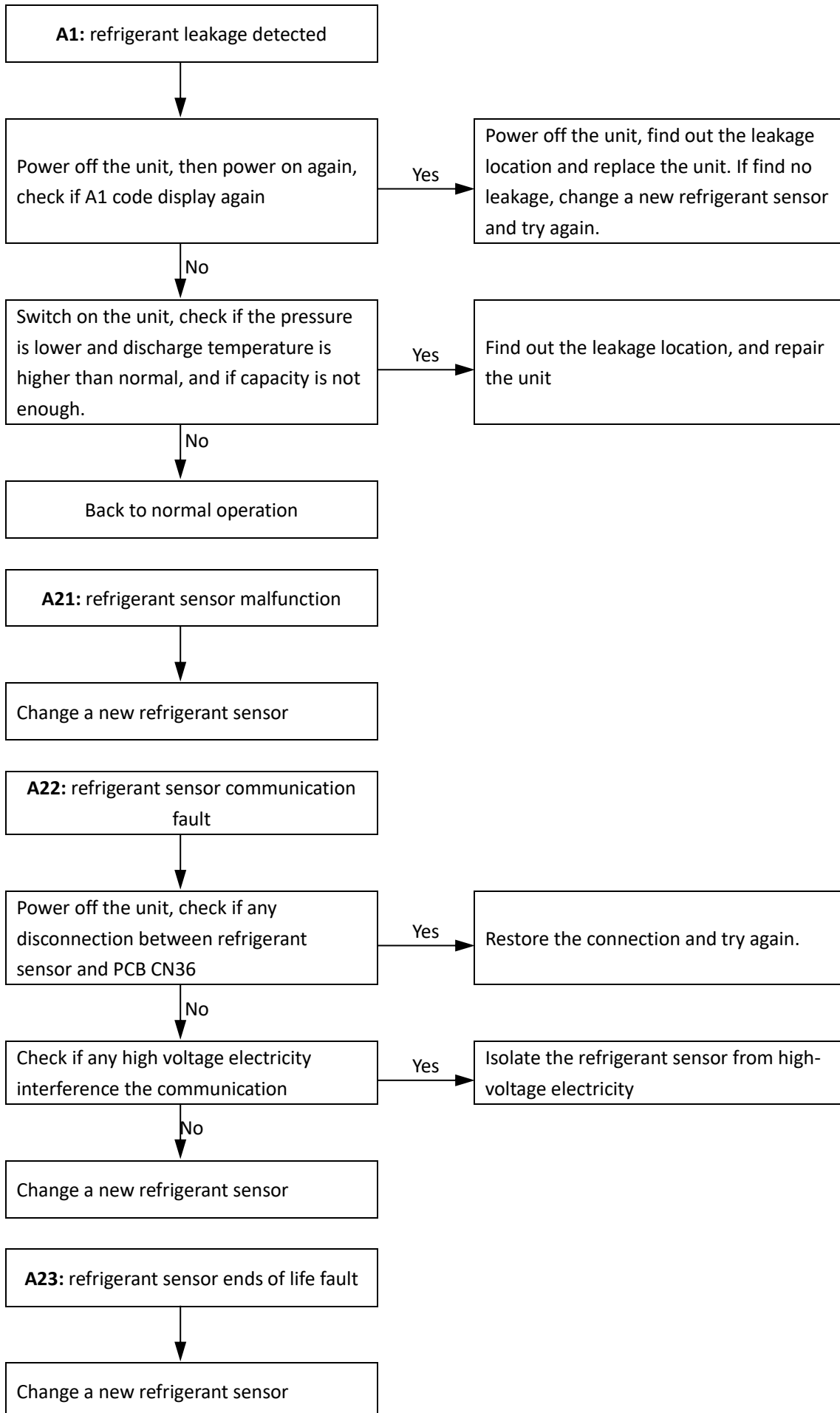

7 Discharge / Suction pressure and temperature range

The following parameter ranges are used to roughly determine whether the system is running properly:

Discharge temperature(Tp) on heating/DHW mode	
$T4 < -10^{\circ}\text{C}$	$\text{Twout}+10 < \text{Tp} < \text{Twout}+30$
$-10^{\circ}\text{C} \leq T4 < 10^{\circ}\text{C}$	$\text{Twout}+10 < \text{Tp} < \text{Twout}+30$
$10^{\circ}\text{C} \leq T4 < 25^{\circ}\text{C}$	$\text{Twout}+10 < \text{Tp} < \text{Twout}+25$
$T4 \geq 25^{\circ}\text{C}$	$\text{Twout}+10 < \text{Tp} < \text{Twout}+25$

Note:
 T4: ambient temperature
 Tw_out: leaving water temperature.

Discharge temperature(Tp) on cooling mode				
Tp (°C)	Fx < 44Hz	44Hz ≤ Fx < 62Hz	62Hz ≤ Fx < 72Hz	Fx ≥ 72Hz
$T4 < 25^{\circ}\text{C}$	50 ± 10	55 ± 10	60 ± 10	65 ± 10
$25^{\circ}\text{C} \leq T4 < 30^{\circ}\text{C}$	55 ± 10	60 ± 10	65 ± 10	70 ± 10
$30^{\circ}\text{C} \leq T4 < 35^{\circ}\text{C}$	60 ± 10	65 ± 10	70 ± 10	75 ± 10
$35^{\circ}\text{C} \leq T4 < 40^{\circ}\text{C}$	65 ± 10	70 ± 10	75 ± 10	80 ± 10
$40^{\circ}\text{C} \leq T4 < 46^{\circ}\text{C}$	70 ± 10	75 ± 10	80 ± 10	85 ± 10
$T4 \geq 46^{\circ}\text{C}$	70 ± 10	75 ± 10	80 ± 10	85 ± 10

Note:
 T4: ambient temperature
 Fx: compressor frequency

Discharge pressure(P1) for heating/DHW mode						
Tw_out(°C)	25	30	35	40	45	50
P1 (kPa)	1000 ± 100	1150 ± 100	1300 ± 100	1450 ± 100	1600 ± 100	1800 ± 100
Tw_out(°C)	55	60	65	70	75	
P1 (kPa)	2000 ± 150	2200 ± 150	2450 ± 150	2700 ± 150	3000 ± 150	

Note: P1 is absolute pressure.

Suction pressure(P2) for cooling mode							
Tw_out(°C)	5~7	8~10	11~13	14~16	17~19	20~22	23~25
P2 (kPa)	520 ± 50	570 ± 50	610 ± 50	670 ± 50	740 ± 50	780 ± 50	830 ± 50

Note: P2 is absolute pressure.

8 Appendix to Part 4

8.1 Temperature Sensor Resistance Characteristics

Applied to							
T3 Outdoor unit heat exchanger bottom temperature sensor							
T4 Ambient temperature sensor							
Th Return-air temperature sensor							
T2 Plate heat exchanger outlet refrigerant temperature sensor							
T2B Plate heat exchanger inlet refrigerant temperature sensor							
TL Outdoor unit heat exchanger outlet temperature sensor							
R25=10K Ω ±3%,B25/50=4100K ±3%							
Temp. (°C)	Resistance (kΩ)			Temp. (°C)	Resistance (kΩ)		
	Rmax	R (t) Normal	Rmin		Rmax	R (t) Normal	Rmin
-40	433.108	383.315	336.854	-8	57.649	53.458	49.492
-39	404.038	358.094	315.212	-7	54.456	50.575	46.899
-38	377.08	334.677	295.088	-6	51.456	47.862	44.455
-37	352.071	312.924	276.365	-5	48.636	45.308	42.15
-36	328.859	292.709	258.939	-4	45.984	42.903	39.977
-35	307.306	273.916	242.714	-3	43.49	40.638	37.927
-34	287.285	256.435	227.599	-2	41.144	38.504	35.992
-33	268.678	240.17	213.514	-1	38.935	36.492	34.165
-32	251.38	225.029	200.382	0	36.857	34.596	32.44
-31	235.291	210.929	188.133	1	34.898	32.807	30.81
-30	220.32	197.792	176.705	2	33.055	31.12	29.271
-29	206.384	185.547	166.037	3	31.317	29.528	27.815
-28	193.407	174.131	156.075	4	29.681	28.026	26.44
-27	181.317	163.481	146.768	5	28.138	26.608	25.14
-26	170.049	153.543	138.071	6	26.682	25.268	23.909
-25	159.543	144.266	129.939	7	25.31	24.003	22.745
-24	149.745	135.601	122.333	8	24.016	22.808	21.644
-23	140.602	127.507	115.216	9	22.794	21.678	20.601
-22	132.067	119.941	108.555	10	21.641	20.61	19.614
-21	124.098	112.867	102.318	11	20.553	19.601	18.68
-20	116.539	106.732	96.92	12	19.525	18.646	17.794
-19	110.231	100.552	91.451	13	18.554	17.743	16.955
-18	103.743	94.769	86.328	14	17.636	16.888	16.16
-17	97.673	89.353	81.525	15	16.769	16.079	15.406
-16	91.99	84.278	77.017	16	15.949	15.313	14.691
-15	86.669	79.521	72.788	17	15.174	14.588	14.014
-14	81.684	75.059	68.815	18	14.442	13.902	13.372
-13	77.013	70.873	65.083	19	13.748	13.251	12.762
-12	72.632	66.943	61.574	20	13.093	12.635	12.183
-11	68.523	63.252	58.274	21	12.471	12.05	11.634
-10	64.668	59.784	55.169	22	11.883	11.496	11.112
-9	61.048	56.524	52.246	23	11.327	10.971	10.617

Continue on next page...

M thermal Nature Plus Series



Temp. (°C)	Resistance (kΩ)			Temp. (°C)	Resistance (kΩ)		
	Rmax	R (t) Normal	Rmin		Rmax	R (t) Normal	Rmin
24	10.8	10.473	10.147	66	2.004	1.883	1.766
25	10.3	10	9.7	67	1.934	1.816	1.702
26	9.848	9.551	9.255	68	1.867	1.752	1.641
27	9.418	9.125	8.834	69	1.802	1.69	1.582
28	9.01	8.721	8.434	70	1.74	1.631	1.525
29	8.621	8.337	8.055	71	1.68	1.574	1.471
30	8.252	7.972	7.695	72	1.622	1.519	1.419
31	7.9	7.625	7.353	73	1.567	1.466	1.369
32	7.566	7.296	7.029	74	1.514	1.416	1.321
33	7.247	6.982	6.721	75	1.463	1.367	1.275
34	6.944	6.684	6.428	76	1.414	1.321	1.23
35	6.656	6.401	6.15	77	1.367	1.276	1.188
36	6.381	6.131	5.886	78	1.321	1.233	1.147
37	6.119	5.874	5.634	79	1.277	1.191	1.108
38	5.87	5.63	5.395	80	1.235	1.151	1.07
39	5.631	5.397	5.167	81	1.195	1.113	1.034
40	5.404	5.175	4.951	82	1.156	1.076	0.999
41	5.188	4.964	4.745	83	1.118	1.041	0.966
42	4.982	4.763	4.549	84	1.082	1.007	0.934
43	4.785	4.571	4.362	85	1.047	0.974	0.903
44	4.596	4.387	4.183	86	1.014	0.942	0.874
45	4.417	4.213	4.014	87	0.982	0.912	0.845
46	4.246	4.046	3.851	88	0.951	0.883	0.818
47	4.082	3.887	3.697	89	0.921	0.855	0.791
48	3.925	3.735	3.55	90	0.892	0.828	0.766
49	3.776	3.59	3.409	91	0.864	0.802	0.742
50	3.632	3.451	3.274	92	0.838	0.777	0.719
51	3.495	3.318	3.146	93	0.812	0.753	0.696
52	3.363	3.191	3.023	94	0.787	0.73	0.675
53	3.237	3.069	2.905	95	0.763	0.708	0.654
54	3.116	2.952	2.793	96	0.74	0.686	0.634
55	3.001	2.841	2.685	97	0.718	0.666	0.615
56	2.89	2.734	2.582	98	0.697	0.646	0.597
57	2.784	2.632	2.484	99	0.677	0.627	0.579
58	2.682	2.534	2.39	100	0.657	0.609	0.562
59	2.585	2.44	2.299	101	0.638	0.591	0.546
60	2.491	2.35	2.213	102	0.62	0.574	0.53
61	2.401	2.264	2.13	103	0.602	0.558	0.515
62	2.315	2.181	2.051	104	0.585	0.542	0.501
63	2.233	2.102	1.975	105	0.569	0.527	0.485
64	2.154	2.026	1.903				
65	2.077	1.953	1.833				

End

Applied to
Tp Discharge temperature sensor

R90 °C=5KΩ±3%,B25/50=3950K±3%

Temp. (°C)	Resistance (kΩ)			Temp. (°C)	Resistance (kΩ)		
	Rmax	R (t) Normal	Rmin		Rmax	R (t) Normal	Rmin
-40	2002.628	1642.059	1281.49	-8	318.604	271.634	224.664
-39	1881.964	1544.968	1207.972	-7	302.08	257.867	213.653
-38	1769.292	1454.213	1139.134	-6	286.483	244.857	203.232
-37	1664.009	1369.32	1074.631	-5	271.757	232.561	193.365
-36	1565.57	1289.862	1014.154	-4	257.852	220.937	184.022
-35	1473.481	1215.451	957.421	-3	244.717	209.945	175.173
-34	1387.282	1145.725	904.168	-2	232.309	199.55	166.79
-33	1306.554	1080.355	854.156	-1	220.585	189.716	158.848
-32	1230.918	1019.042	807.166	0	209.504	180.412	151.321
-31	1160.015	961.505	762.994	1	199.029	171.607	144.186
-30	1093.521	907.487	721.452	2	189.125	163.273	137.422
-29	1031.137	856.752	682.368	3	179.759	155.383	131.007
-28	972.588	809.086	645.583	4	170.899	147.911	124.923
-27	917.615	764.281	610.947	5	162.517	140.835	119.152
-26	865.981	722.152	578.323	6	154.585	134.13	113.675
-25	817.469	682.528	547.586	7	147.077	127.778	108.478
-24	771.875	645.245	518.616	8	139.97	121.757	103.544
-23	729.009	610.156	491.303	9	133.239	116.049	98.859
-22	688.698	577.121	465.544	10	126.864	110.638	94.411
-21	650.778	546.012	441.246	11	120.825	105.505	90.185
-20	615.097	516.708	418.318	12	115.103	100.636	86.17
-19	581.515	489.096	396.678	13	109.679	96.017	82.354
-18	549.899	463.073	376.247	14	104.537	91.633	78.728
-17	520.129	438.542	356.955	15	99.662	87.471	75.28
-16	492.089	415.411	338.733	16	95.038	83.52	72.001
-15	465.672	393.595	321.518	17	90.652	79.767	68.882
-14	440.779	373.014	305.25	18	86.489	76.202	65.915
-13	417.316	353.595	289.874	19	82.539	72.815	63.091
-12	395.197	335.268	275.339	20	78.789	69.596	60.404
-11	374.34	317.967	261.594	21	75.228	66.537	57.845
-10	354.669	301.632	248.595	22	71.846	63.627	55.409
-9	336.113	286.206	236.298	23	68.633	60.86	53.088

Continue on next page...

Temp. (°C)	Resistance (kΩ)			Temp. (°C)	Resistance (kΩ)		
	Rmax	R (t) Normal	Rmin		Rmax	R (t) Normal	Rmin
24	65.58	58.228	50.877	66	11.858	11.134	10.411
25	62.678	55.724	48.77	67	11.432	10.749	10.066
26	59.919	53.34	46.762	68	11.024	10.38	9.735
27	57.295	51.071	44.847	69	10.632	10.024	9.416
28	54.8	48.91	43.021	70	10.255	9.682	9.109
29	52.426	46.853	41.279	71	9.894	9.354	8.814
30	50.167	44.892	39.617	72	9.546	9.038	8.53
31	48.016	43.024	38.031	73	9.213	8.734	8.255
32	45.969	41.243	36.517	74	8.892	8.442	7.992
33	44.019	39.546	35.072	75	8.584	8.161	7.737
34	42.162	37.927	33.692	76	8.288	7.89	7.492
35	40.392	36.383	32.373	77	8.003	7.629	7.256
36	38.706	34.91	31.113	78	7.729	7.379	7.028
37	37.098	33.504	29.909	79	7.466	7.137	6.809
38	35.566	32.162	28.758	80	7.213	6.905	6.597
39	34.104	30.881	27.657	81	6.969	6.681	6.393
40	32.709	29.657	26.605	82	6.735	6.466	6.196
41	31.379	28.488	25.598	83	6.509	6.258	6.006
42	30.109	27.372	24.634	84	6.292	6.058	5.823
43	28.896	26.304	23.712	85	6.084	5.865	5.646
44	27.739	25.284	22.829	86	5.883	5.679	5.476
45	26.633	24.309	21.984	87	5.689	5.5	5.311
46	25.577	23.376	21.174	88	5.502	5.327	5.152
47	24.568	22.483	20.399	89	5.323	5.161	4.998
48	23.603	21.629	19.656	90	5.15	5	4.85
49	22.681	20.812	18.943	91	4.996	4.845	4.694
50	21.799	20.03	18.261	92	4.847	4.696	4.545
51	20.956	19.281	17.606	93	4.703	4.552	4.4
52	20.149	18.563	16.978	94	4.564	4.412	4.261
53	19.377	17.876	16.375	95	4.43	4.278	4.127
54	18.638	17.218	15.797	96	4.3	4.149	3.997
55	17.931	16.587	15.243	97	4.175	4.024	3.872
56	17.254	15.982	14.71	98	4.054	3.903	3.752
57	16.606	15.402	14.199	99	3.937	3.787	3.636
58	15.984	14.846	13.708	100	3.824	3.674	3.524
59	15.389	14.313	13.236	101	3.715	3.565	3.416
60	14.819	13.801	12.783	102	3.609	3.46	3.312
61	14.272	13.31	12.348	103	3.507	3.359	3.211
62	13.748	12.839	11.929	104	3.409	3.261	3.114
63	13.246	12.387	11.527	105	3.313	3.167	3.02
64	12.764	11.952	11.14	106	3.221	3.075	2.929
65	12.302	11.535	10.768	107	3.131	2.987	2.842

Continue on next page...

Temp. (°C)	Resistance (kΩ)			Temp. (°C)	Resistance (kΩ)		
	Rmax	R (t) Normal	Rmin		Rmax	R (t) Normal	Rmin
108	3.045	2.901	2.758	132	1.625	1.511	1.397
109	2.962	2.819	2.676	133	1.586	1.473	1.36
110	2.881	2.739	2.597	134	1.548	1.436	1.324
111	2.802	2.662	2.521	135	1.511	1.401	1.29
112	2.727	2.587	2.448	136	1.475	1.366	1.257
113	2.653	2.515	2.377	137	1.44	1.332	1.225
114	2.582	2.445	2.308	138	1.407	1.3	1.193
115	2.514	2.378	2.242	139	1.374	1.268	1.163
116	2.447	2.313	2.178	140	1.342	1.238	1.133
117	2.383	2.249	2.116	141	1.311	1.208	1.105
118	2.32	2.188	2.056	142	1.281	1.179	1.077
119	2.26	2.129	1.998	143	1.252	1.151	1.051
120	2.201	2.072	1.942	144	1.224	1.124	1.024
121	2.145	2.016	1.888	145	1.196	1.098	0.999
122	2.09	1.963	1.836	146	1.169	1.072	0.975
123	2.037	1.911	1.785	147	1.143	1.047	0.951
124	1.985	1.86	1.736	148	1.118	1.023	0.928
125	1.935	1.812	1.689	149	1.093	0.999	0.905
126	1.887	1.765	1.643	150	1.069	0.977	0.884
127	1.84	1.719	1.598				
128	1.794	1.675	1.555				
129	1.75	1.632	1.514				
130	1.707	1.59	1.473				
131	1.665	1.55	1.434				

End

Applied to
 TW_in Plate heat exchanger inlet water temperature sensor
 TW_out Plate heat exchanger outlet water temperature sensor
 T5 Water tank temperature sensor
 TW2 Zone 2 water flow temperature sensor

R50=17.6KΩ±3%,B0/100=3970K±2%

Temp. (°C)	Resistance (kΩ)			Temp. (°C)	Resistance (kΩ)		
	Rmax	R (t) Normal	Rmin		Rmax	R (t) Normal	Rmin
-40	1822.916	1608.351	1393.786	-8	263.273	242.131	220.989
-39	1705.939	1507.271	1308.602	-7	249.357	229.593	209.828
-38	1596.976	1412.994	1229.013	-6	236.255	217.774	199.293
-37	1495.47	1325.058	1154.647	-5	223.915	206.63	189.345
-36	1400.897	1243.025	1085.152	-4	212.289	196.119	179.949
-35	1312.771	1166.486	1020.2	-3	201.332	186.201	171.07
-34	1230.637	1095.061	959.485	-2	191.001	176.84	162.678
-33	1154.07	1028.393	902.717	-1	181.258	168.001	154.744
-32	1082.675	966.151	849.626	0	172.066	159.653	147.24
-31	1016.084	908.023	799.962	1	163.391	151.766	140.141
-30	953.957	853.724	753.491	2	155.2	144.311	133.422
-29	896.053	802.986	709.918	3	147.466	137.264	127.062
-28	842.002	755.557	669.113	4	140.159	130.599	121.038
-27	791.53	711.21	630.889	5	133.253	124.293	115.332
-26	744.384	669.728	595.072	6	126.725	118.326	109.926
-25	700.328	630.913	561.498	7	120.554	112.679	104.803
-24	659.144	594.58	530.015	8	114.715	107.33	99.945
-23	620.629	560.556	500.483	9	109.191	102.265	95.338
-22	584.595	528.683	472.771	10	103.963	97.466	90.969
-21	550.871	498.814	446.757	11	99.013	92.918	86.822
-20	519.295	470.812	422.328	12	94.327	88.607	82.888
-19	489.718	444.548	399.379	13	89.887	84.519	79.152
-18	462.003	419.907	377.812	14	85.679	80.642	75.604
-17	436.022	396.779	357.537	15	81.692	76.963	72.234
-16	411.657	375.063	338.468	16	77.911	73.471	69.032
-15	388.797	354.662	320.527	17	74.326	70.157	65.989
-14	367.343	335.492	303.641	18	70.925	67.011	63.097
-13	347.198	317.47	287.743	19	67.699	64.023	60.347
-12	328.275	300.521	272.767	20	64.636	61.184	57.731
-11	310.495	284.576	258.658	21	61.729	58.486	55.243
-10	293.78	269.569	245.359	22	58.967	55.921	52.875
-9	278.06	255.439	232.818	23	56.345	53.483	50.621

Continue on next page...

Temp. (°C)	Resistance (kΩ)			Temp. (°C)	Resistance (kΩ)		
	Rmax	R (t) Normal	Rmin		Rmax	R (t) Normal	Rmin
24	53.854	51.165	48.476	66	10.231	9.818	9.405
25	51.485	48.959	46.432	67	9.887	9.481	9.075
26	49.234	46.86	44.486	68	9.556	9.157	8.758
27	47.094	44.863	42.632	69	9.237	8.846	8.454
28	45.058	42.961	40.865	70	8.932	8.547	8.163
29	43.121	41.151	39.181	71	8.637	8.259	7.882
30	41.278	39.427	37.575	72	8.354	7.983	7.613
31	39.524	37.784	36.044	73	8.08	7.717	7.354
32	37.854	36.219	34.583	74	7.818	7.461	7.105
33	36.263	34.726	33.189	75	7.565	7.215	6.866
34	34.748	33.304	31.86	76	7.322	6.978	6.635
35	33.305	31.947	30.59	77	7.087	6.75	6.414
36	31.929	30.653	29.378	78	6.861	6.531	6.201
37	30.617	29.419	28.22	79	6.643	6.319	5.995
38	29.367	28.241	27.114	80	6.433	6.115	5.798
39	28.174	27.115	26.057	81	6.23	5.919	5.608
40	27.036	26.042	25.048	82	6.035	5.73	5.425
41	25.949	25.015	24.082	83	5.847	5.548	5.249
42	24.913	24.036	23.159	84	5.666	5.372	5.079
43	23.924	23.1	22.276	85	5.491	5.204	4.916
44	22.979	22.206	21.432	86	5.323	5.041	4.759
45	22.076	21.35	20.624	87	5.16	4.884	4.608
46	21.213	20.532	19.85	88	5.003	4.732	4.462
47	20.389	19.749	19.11	89	4.852	4.587	4.322
48	19.602	19.001	18.401	90	4.706	4.446	4.186
49	18.848	18.285	17.722	91	4.565	4.31	4.056
50	18.128	17.6	17.072	92	4.429	4.179	3.929
51	17.466	16.944	16.422	93	4.298	4.053	3.809
52	16.831	16.316	15.801	94	4.172	3.932	3.692
53	16.223	15.714	15.206	95	4.049	3.814	3.579
54	15.641	15.139	14.638	96	3.932	3.701	3.471
55	15.081	14.586	14.092	97	3.817	3.591	3.365
56	14.545	14.058	13.571	98	3.708	3.486	3.265
57	14.03	13.55	13.07	99	3.601	3.384	3.167
58	13.537	13.064	12.591	100	3.499	3.286	3.073
59	13.063	12.597	12.132	101	3.4	3.191	2.983
60	12.608	12.15	11.692	102	3.303	3.098	2.894
61	12.171	11.721	11.27	103	3.21	3.009	2.809
62	11.752	11.309	10.866	104	3.12	2.923	2.727
63	11.349	10.913	10.478	105	3.032	2.84	2.647
64	10.962	10.533	10.105	106	2.948	2.759	2.571
65	10.589	10.168	9.748	107	2.866	2.681	2.497

Continue on next page...

Temp. (°C)	Resistance (kΩ)			Temp. (°C)	Resistance (kΩ)		
	Rmax	R (t) Normal	Rmin		Rmax	R (t) Normal	Rmin
108	2.787	2.606	2.425	132	1.477	1.364	1.251
109	2.711	2.533	2.356	133	1.44	1.329	1.219
110	2.637	2.463	2.288	134	1.405	1.296	1.187
111	2.565	2.394	2.224	135	1.37	1.264	1.157
112	2.496	2.328	2.161	136	1.337	1.232	1.127
113	2.428	2.264	2.1	137	1.304	1.202	1.099
114	2.363	2.202	2.041	138	1.273	1.172	1.071
115	2.3	2.142	1.985	139	1.242	1.143	1.044
116	2.239	2.084	1.93	140	1.212	1.115	1.018
117	2.179	2.028	1.876	141	1.183	1.088	0.993
118	2.122	1.973	1.825	142	1.155	1.061	0.968
119	2.066	1.92	1.775	143	1.127	1.036	0.944
120	2.012	1.869	1.726	144	1.101	1.011	0.921
121	1.96	1.82	1.68	145	1.075	0.986	0.898
122	1.909	1.772	1.634	146	1.05	0.963	0.876
123	1.86	1.725	1.59	147	1.025	0.94	0.855
124	1.812	1.68	1.548	148	1.001	0.918	0.834
125	1.765	1.636	1.506	149	0.978	0.896	0.814
126	1.72	1.593	1.466	150	0.955	0.875	0.794
127	1.677	1.552	1.428				
128	1.634	1.512	1.39				
129	1.593	1.473	1.354				
130	1.553	1.436	1.318				
131	1.515	1.399	1.284				

End

8.2 Pressure and Output voltage characteristics of Pressure sensor

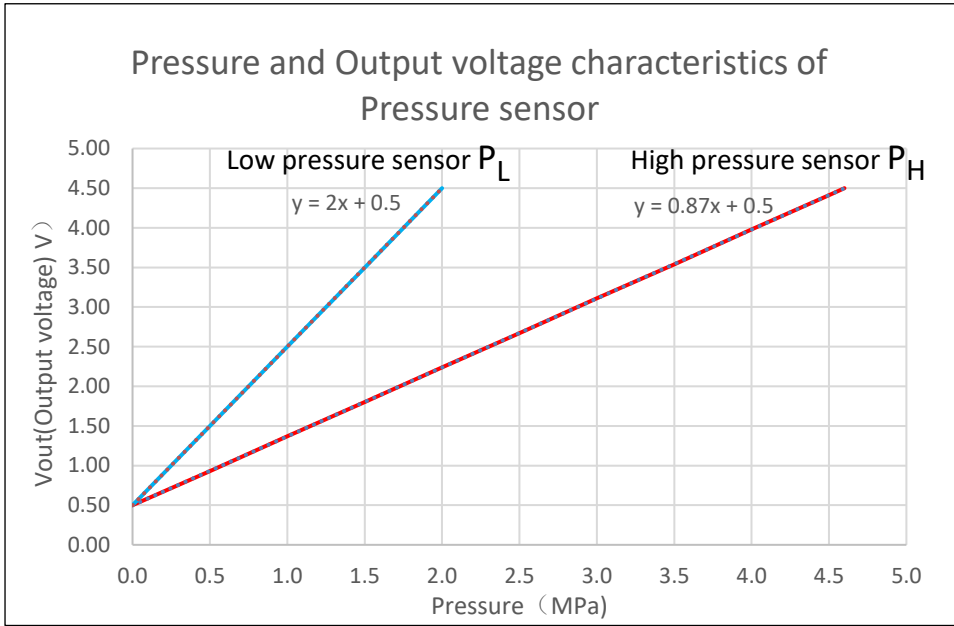

Output voltage formula of high-pressure sensor: $V_{out}(H)=0.87 \times P_H+0.5$

Output voltage formula of low-pressure sensor: $V_{out}(L)=2 \times P_L+0.5$

Measure the output voltage of pressure sensor

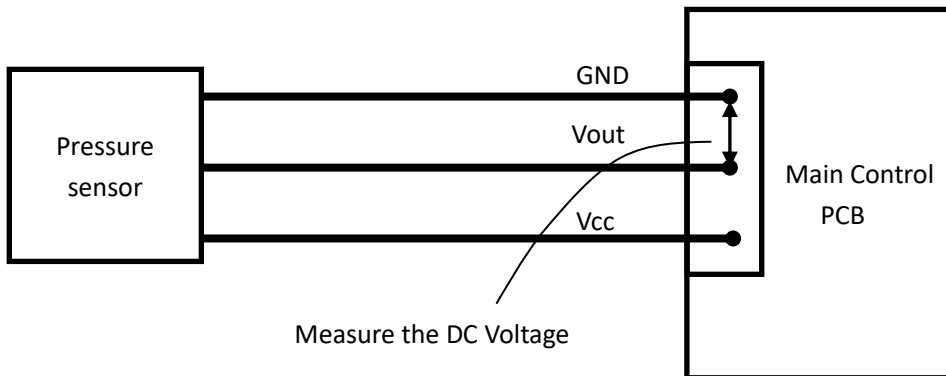

M thermal Nature Plus Series

8.3 Guide for identifying inverter PCB failure

Before measuring the inverter PCB, please confirm steps below in advance :

- 1) Cut off the power supply ;
- 2) Wait for 10 mins for capacitor discharging in order to avoid the electric shock
- 3) Remove all connections wires
- 4) To identify whether inverter PCB of 1Ph models failed, follow the guide to test inverter circuit. If any one of test value abnormal, the 1 Ph inverter PCB failed.

To identify whether inverter PCB of 3Ph models failed, follow the guide to test inverter circuit and three phase bridge rectifier. If any one of test value abnormal, the 3 Ph inverter PCB failed.

Preparing tools: multimeter (secondary tube is available)

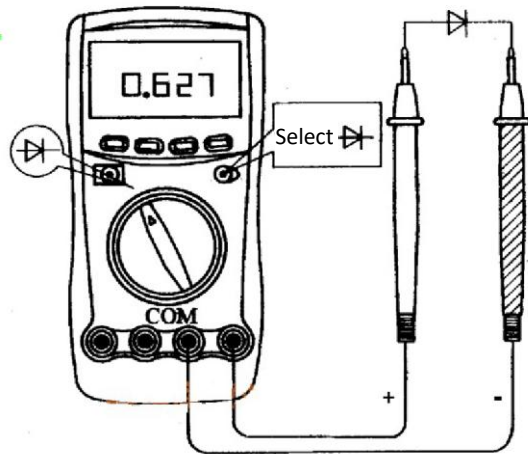

Inverter circuit (Fan module/ Compressor module):

Order	Test point		Normal	Abnormal
	+(Red)	- (Black)		
1	U	P	0.3-0.7V	0 /infinite
2	V	P		
3	W	P		
4	N	U		
5	N	V		
6	N	W		

Note:

1. If any one of test value abnormal, the inverter PCB failed. Request aftersales service and replace the inverter control box.

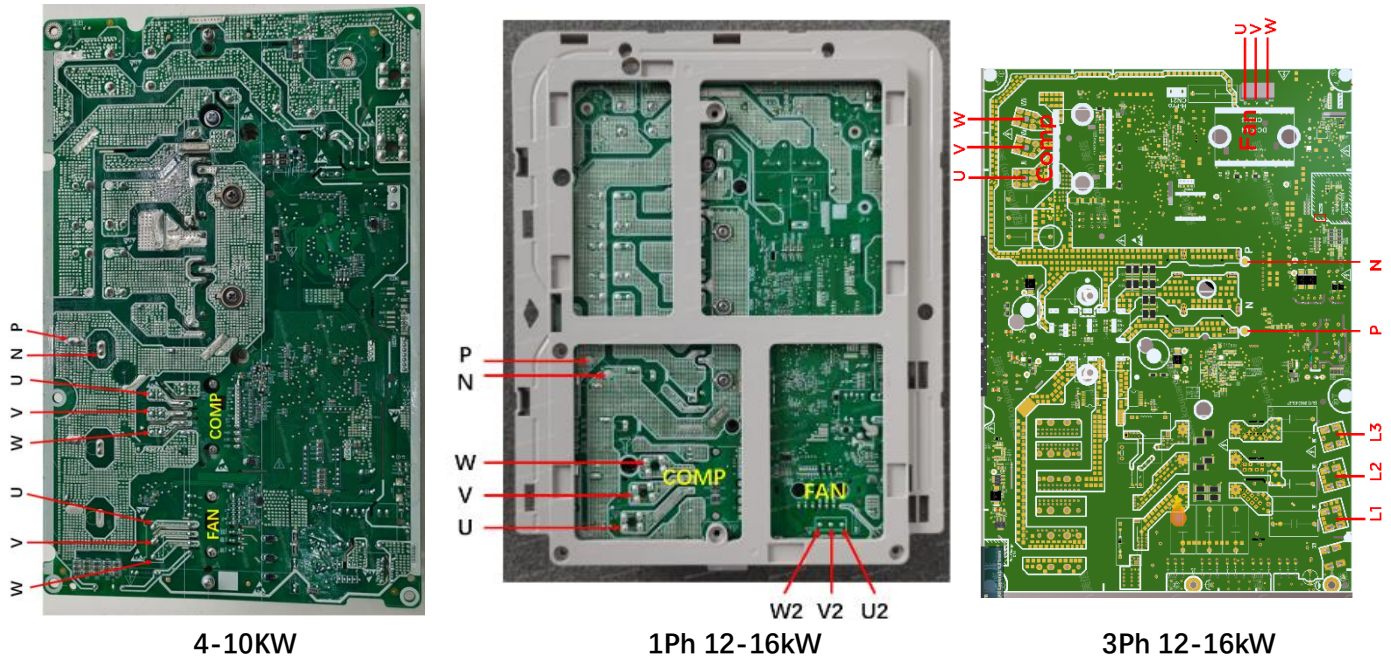

Three phase bridge rectifier:

Order	Test point		Normal	Abnormal
	+(Red)	- (Black)		
1	L1	P	0.3-0.7V	0 /infinite
2	L2	P		
3	L3	P		
4	N	L1		
5	N	L2		
6	N	L3		

Note:

If any one of test value is abnormal, the inverter PCB failed. Request aftersales service and replace the inverter control box.

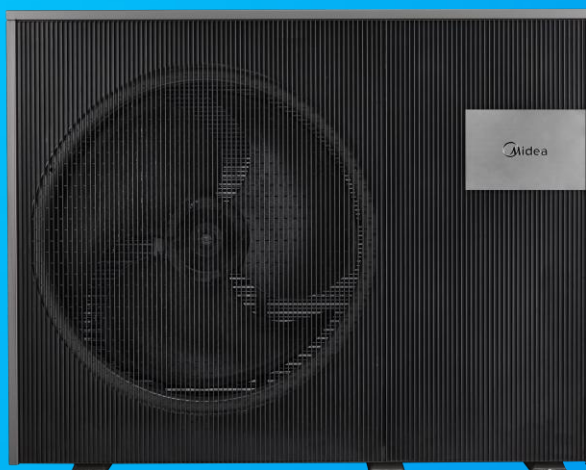

Midea will introduce a new generation of heat pumps that operate using R290 refrigerant. Theoretically, R290 is a highly flammable A3 refrigerant, but its risk can be effectively eliminated through product design and various aspects of control. This refrigerant has also been widely used in air conditioners, refrigerators, heat pumps, and other products in recent years. A3 refrigerant handling is therefore neither novel nor unusual. However, some basic precautions must be taken during storage, transportation, installation, maintenance, etc., which will be explained on the following pages.

General information

Characteristics of R290 refrigerant

Environmental protection: R290 is an environmentally friendly refrigerant with a global warming potential (GWP) of 0.02 and no ozone depletion potential (ODP).

High efficiency: R290 has good heat transfer properties and provides efficient refrigeration and air conditioning. It features a wide range of applications (up to -40°C).

Safety: R290 refrigerant (propane) is a colorless, odorless gas used in refrigeration and air conditioning equipment. It is non-toxic and highly flammable when mixed with air at a concentration of 0.021 to 0.095. R290 is heavier than air at the same temperature and pressure and often reaches higher concentrations near the ground. The gas has no odor, but it can be easily detected by commercially available gas detectors and leak detection devices, and its risk can be eliminated through effective preventative measures.

Basic information on R290 heat pumps

The new generation of R290 heat pumps now adopts a monolithic structure design. This means that the refrigeration circuit of the unit is hermetically sealed, the refrigeration circuit is completely inside the heating system, and it is fully charged with R290 refrigerant when delivered. The maximum refrigerant charging amount for a single heat pump is 1250 g. More details can be found on Midea's official website.

Explanation of common symbols on the heat pump

	WARNING	This symbol shows that this appliance used a flammable refrigerant. If the refrigerant is leaked and exposed to an external ignition source, there is a risk of fire.
	CAUTION	No open flame; Fire, open ignition sources, and smoking are prohibited.
	CAUTION	This symbol shows that service personnel should be handling this equipment with reference to the installation manual.
	CAUTION	This symbol shows that information is available, such as the operating manual or installation manual.

Transportation precautions

Transportation regulations: ADR, IMDG, IATA

ADR regulations: Equipment containing less than 12 kg of flammable refrigerant is not subject to transportation regulations if it is designed with protection (i.e., it meets the appropriate safety standards). If the refrigerant amount exceeds 12 kg, the equipment is subject to the regulations for any containers for flammable gases.

IMDG regulations: R290 is classified as a flammable gas and defined as 2.1 class: it does not produce obvious flames or explosions during combustion, but produces heat and gas within its flammable range. The explosion limit of this gas is relatively high, and once exceeded, it can cause dangerous explosions. It is required that the shipper provides the corresponding MSDS for the product, which stands for Material Safety Data Sheet. The maximum filling quantity for flammable refrigerants is limited to 12 kg.

IATA regulations: These regulations prohibit the transportation of equipment charged with more than 0.1 kg of combustible refrigerant by a passenger plane or cargo aircraft. If air transportation is required, up to 150 kg of flammable refrigerant can be carried in cylinders, so that the system can be charged on site.

Basic requirements for transportation





1. For finished machines, the carrier vehicle cannot be fully enclosed during transportation.
2. Red-and-white reflective strips should be pasted at the sides and rear of the carrier vehicle to alert other vehicles to keep a safe distance. The vehicle should not get close to the high-temperature area during transportation. Take heat dissipation measures when the temperature inside the compartment is too high.
3. Refrigerants and products to be repaired are not allowed to be transported in the open air, and the compartment should be equipped with an anti-static device.
4. A combustible agent leakage alarm device, an anti-static device, and a fire extinguishing device should be equipped.

Storage precautions

Basic requirements for warehouse

1. The warehouse should be equipped with ventilation equipment. Before entering the warehouse, the personnel should first turn on the ventilation equipment. Explosion-proof ventilation equipment and electrical appliances should be used in the warehouse. When conditions do not permit, at least explosion-proof exhaust fans should be used. All electrical appliances should be installed at a height of over 1.5 meters.
2. The warehouse should be illuminated, spacious, open, well-ventilated, equipped with ventilation equipment, and located in a place without heat sources.
3. When a refrigerant leak is detected, the ventilation equipment must be turned on immediately.

Warehouse management requirements

	<p>Only desk telephones will be set up for communication within the warehouse. No mobile phones are allowed.</p>
	<p>A combustible gas leakage detection device should be installed in the warehouse.</p>
	<p>Product placement requirements: One side of the box surface must have a visible fireproof label and cannot be obstructed by other products.</p>
	<p>The warehouse should be equipped with dry powder or carbon dioxide fire extinguishers and other fire-fighting equipment suitable for extinguishing electrical fires.</p>

Refrigerant leakage handling plan

Rapidly evacuate people from the contaminated leakage area to a windward location and isolate them until the gas is fully dissipated. Cut off the fire source. Emergency responders should wear a self-contained breathing apparatus and an anti-static fire protection suit. Cut off the gas source, spray water mist for dilution and dissolution, or take extraction (indoor) or strong ventilation (outdoor) measures. If possible, use explosion-proof exhaust fans to transfer the leaked gas to an open place or install an appropriate nozzle to burn it off. Optionally, move the container with air leakage to an open place. Note that containers that gush air or which have air leakage cannot be used again, and technical measures should be taken to eliminate the remaining gas.

Installation and commissioning precautions

1. Installation environment check: The heat pump is not allowed to be installed in an enclosed building space.
2. Unpacking check: The product should be unpacked and inspected in a well-ventilated area. A concentration detector should be prepared before heat pump unpacking to check for damage and abnormal appearance.
3. Installation height check: Not less than 1.0 m for window units, not less than 1.8 m for split wall-mounted units, and not less than 2.2 m for ceiling-mounted units.
4. Grounding check: The user's power supply should be grounded with a grounding resistance of no more than 4Ω. The air conditioner grounding wires must be firmly connected to the metal shells of the heat pump and ODU and thoroughly checked using a multimeter. Arrange a dedicated power supply line and connect it directly to the air conditioner's power supply.
5. Support installation: The support must be subjected to a test and a corrosion resistance test at more than 4 times the weight of the unit before use.
6. Heat pump fixing: When installing the heat pump, place the refrigerant piping connectors outdoors if possible. When fixing a wall-mounted heat pump, the distance between the two

sides of the unit and the wall should be more than 65 cm, the bottom of the unit must be more than 1.8 m above the ground, and an installation height of more than 15 cm should be maintained on the top of the heat pump.

7. ODU installation: The clearance between the ODU and the inner wall should not be less than 75 cm. Connect the heat pump power cable, signal cable, and ODU's electrical part and take proper insulation measures. Be sure to make a ground connection.
8. ODU refrigerant pressure check: Check whether the compressor's discharge pressure and air return pressure are within a reasonable range (air return: 0.4–0.6 MPa; discharge: 1.5–2.0 MPa).
9. IDU and ODU connection pipes: It is prohibited to use removable connections for heat pump pipes. Avoid laying the connection pipes in an area with any sources of flame.
10. System vacuumizing: Use a dedicated vacuum pump for combustible refrigerants to vacuumize the system pipelines. It is prohibited to use refrigerants for vacuumizing.
11. Test run: Test runs must be performed after the installation is complete. During test runs, perform leakage inspections for pipe connections. Tightly seal the room where the heat pump is located and check for refrigerant leaks.
12. Electrical inspection: Perform a grounding check on the heat pump sheet metal. Power off and perform an insulation resistance test on the entire unit. The live line + null line insulation resistance to ground should be greater than 10 MΩ.

Precautions for maintenance requirements

Installation safety principles

1. The premises for installation should be kept ventilated.
2. Open flame or a high-temperature heat source with a temperature higher than 370°C, such as welding or smoking, are prohibited.
3. Take anti-static measures.
4. Choose a place that is convenient for installation and maintenance, which should not be an environment that is close to heat sources or exposed to flammable or explosive materials.
5. During the installation of the heat pump, in the event of refrigerant leakage, immediately close the ODU valve. All personnel should leave the room and handle the leakage 15 minutes later. Damaged products must be transported back to the maintenance point for processing. Welding is prohibited on the user's premises.
6. Choose a place where a uniform air inlet and outlet of the heat pump can be guaranteed.
7. Keep both sides of the area underneath the unit away from electric appliances, power switches, sockets, and other items.

Tools required



Vacuum pump

When performing pipeline welding or replacing refrigerant during charging, it is necessary to use an explosion-proof vacuum pump.



Charging equipment

The refrigerant must be charged using dedicated explosion-proof charging equipment. Accuracy requirement: The deviation of the charging amount is less than 5 g.



Concentration detector

1. Repair facilities should be equipped with fixed R290 flammable refrigerant concentration detectors, which should be connected to safety protection/alarm systems. The error rate should not exceed 5%.
2. The installation site should be equipped with portable R290 flammable refrigerant concentration detectors (catalytic combustion/electronic/infrared), which can achieve two-stage audio and visual alarms. The error rate should not exceed 10%.
3. Detectors need to be calibrated every 30 days.
4. Before using the detector, functional checks and confirmations should be carried out.



Fire extinguisher

During installation and repair, a fire extinguisher should be carried. There should be two or more dry powder, carbon dioxide, or foam fire extinguishers available at the repair site, placed in designated locations, with prominent identification, and easily accessible.

Midea Building Technologies Division
Midea Group

Address: Midea Headquarters Building, 6 Midea Avenue, Shunde, Foshan, Guangdong, China

Postal code: 528311

mbt.midea.com / global.midea.com

Midea reserves the right to change the specifications of the product, and to withdraw or replace products without prior notification or public announcement. Midea is constantly developing and improving its products.

Please note that all pictures in the document are for reference only. Actual products may vary.

