

INSTALLATION AND OWNER'S MANUAL

M-thermal split Indoor unit



IMPORTANT NOTE:



Original instructions.

Please read this manual carefully and keep it for future reference.

All the pictures in this manual are for illustrations purpose only.

CONTENTS

1	ABOUT THE DOCUMENTATION	01
2	SAFETY PRECAUTIONS	01
3	BEFORE INSTALLATION	06
4	INSTALLATION SITE	06
5	ACCESSORIES	08
5.1	Unpacking	08
5.2	Remove the shipping pallet	09
6	INSTALLATION	10
6.1	Dimensions of the unit	10
6.2	Installation requirements	10
6.3	Servicing space requirements	11
6.4	Mounting the indoor unit	11
6.5	Connecting the refrigerant piping	11
7	GENERAL INTRODUCTION	12
8	CONNECTING THE WATER PIPING	13
8.1	Connecting the space heating(cooling) water piping	13
8.2	Connecting the domestic water piping	13
8.3	Connecting the recirculation water piping	13
8.4	Connecting the drainage hose to the indoor unit	13
8.5	Water piping insulation	14
8.6	Water volume and sizing expansion vessels	14
8.7	Water circuit anti-freeze protection	15
8.8	Water	16
9	OVERVIEW OF THE UNIT	17
9.1	Disassembling the unit	17
9.2	Main components	17
9.3	Electronic control box	19
9.4	Refrigerant pipework	20
9.5	Filling water	20
9.6	Typical applications	22
10	FIELD WIRING	24
10.1	Precautions on electrical wiring work	24
10.2	Precautions on wiring of power supply	26
10.3	Safety device requirements	27
10.4	Before connecting the wiring	27
10.5	Connecting the main power supply	28
10.6	Connecting for other components	29

11 START-UP AND CONFIGURATION	35
11.1 DIP switch settings overview	35
11.2 Initial start-up at low outdoor ambient temperature	35
11.3 Pre-operation checks	36
11.4 Setting the pump	36
11.5 Field settings	38
11.6 Operation settings	42
12 COMMISSIONING	45
12.1 Test run for the actuator	45
12.2 Air purge	46
12.3 Test run	46
12.4 Check of the minimum flow rate	47
13 HAND-OVER TO THE USER	47
13.1 Energy saving tips	47
13.2 Additional operation reference	47
14 TECHNICAL SPECIFICATIONS	51
15 TROUBLE SHOOTING	53
15.1 General guidelines	53
15.2 General symptoms	53
15.3 Error codes	55
16 SAFETY PRECAUTION ABOUT THE APPLIANCES USING FLAMMABLE REFRIGERANT	59
16.1 General	59
16.2 Symbols	59
16.3 Installation	59
16.4 Information on servicing	59
16.5 Sealed electrical components	60
16.6 Cabling	60
16.7 Detection of flammable refrigerants	61
16.8 Refrigerant removal and circuit evacuation	61
16.9 Charging procedures	61
16.10 Decommissioning	62
16.11 Labelling	62
16.12 Recovery	62
ANNEX A: REFRIGERANT CYCLE	63

1 ABOUT THE DOCUMENTATION

This document is part of a documentation set. The complete set consists of:

INSTALLATION AND OWNER'S MANUAL:

- Installation and operation instructions for indoor unit

USER INTERFACE MANUAL:

- Installation and operation instructions for controller.

2 SAFETY PRECAUTIONS

The precautions listed here are divided into the following types. They are quite important, so be sure to follow them carefully.

Read these instructions carefully before installation. Keep this manual in a handy for future preference.

Meanings of DANGER, WARNING, CAUTION and NOTE symbols.

DANGER

It indicates a hazard with a high level of risk which, if not avoided, will result in death or serious injury.

WARNING

It indicates a hazard with a medium level of risk which, if not avoided, could result in death or serious injury.

CAUTION





It indicates a hazard with a low level of risk which, if not avoided, could result in minor or moderate injury.

NOTE

Indicates situations that could only result in accidental equipment or property damage.

WARNING

- Improper installation of equipment or accessories may result in electric shock, short-circuit, leakage, fire or other damage to the equipment. Be sure to only use accessories made by the supplier, which are specifically designed for the equipment and make sure to get installation done by a certified person.
- All the activities described in this manual must be carried out by a licensed technician. Be sure to wear adequate personal protection equipment such as gloves and safety glasses while installing the unit or carrying out maintenance activities.

	WARNING	Flammable refrigerant is applied. A fire may occur due to unexpected leakage of refrigerant.
	CAUTION	Read the operation manual carefully before any further action.
	CAUTION	Only a specialist is allowed to take action under the instructions of the installation manual.
	CAUTION	The information is available in the relevant documentation.



WARNING: Risk of fire/
flammable materials

⚠ WARNING

- Any person who is involved with working on or breaking into a refrigerant circuit should hold a current valid certificate from an industry-accredited assessment authority, which authorises their competence to handle refrigerants safely in accordance with an industry recognised assessment specification.
- Servicing shall only be performed as recommended by the equipment manufacturer. Maintenance and repair requiring the assistance of other skilled personnel shall be carried out under the supervision of the person competent in the use of flammable refrigerants.

Special requirements for R32

⚠ WARNING

- Do NOT have refrigerant leakage and open flame.
- Be aware that the R32 refrigerant does NOT contain an odour.

⚠ WARNING

- The appliance shall be stored in a well-ventilated area where the room size corresponds to the room area as specified for operation.
- The appliance shall be stored in a room without continuously operating open flames (for example an operating gas appliance) and ignition sources (for example an operating electric heater).
- The appliance shall be stored so as to prevent mechanical damage from occurring.

⚠ CAUTION

- Do NOT re-use joints which have been used already.
- Joints made in installation between parts of refrigerant system shall be accessible for maintenance purposes.

⚠ WARNING

Make sure installation, servicing, maintenance and repair comply with instructions and with applicable legislation (for example national gas regulation) and are executed only by authorised persons.

⚠ CAUTION

- Pipework should be protected from physical damage.
- Installation of pipework shall be kept to a minimum length.

If the total refrigerant charge in the system is < 1.84 kg (i.e. if the piping length is < 20 m for 8/10 kW), there are no additional minimum floor area requirement.

If the total refrigerant charge in the system is ≥ 1.84 kg (i.e. if the piping length is ≥ 20 m for 8/10 kW), you need to comply with additional minimum floor area requirements as described in the following flow chart. The flow chart uses the following tables: "Table 1-Maximum refrigerant charge allowed in a room: indoor unit" on page 3, "Table 2-Minimum floor area: indoor unit" on page 4 and "Table 3-Minimum venting opening area for natural ventilation: indoor unit" on page 4.

If the piping length is 30m, then the minimum floor area is $\geq 4.5\text{m}^2$; if the floor area is less than 4.5m^2 , it needs to be trepanned a hole of 200cm^2 .

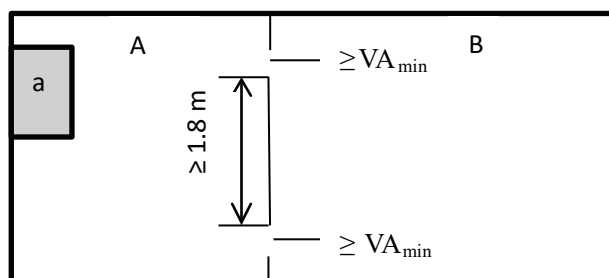

a Indoor unit

A Room where the indoor unit is installed.

B Room adjacent to room A.

The area of A plus B has to be greater than or equal to 4.5m^2 .

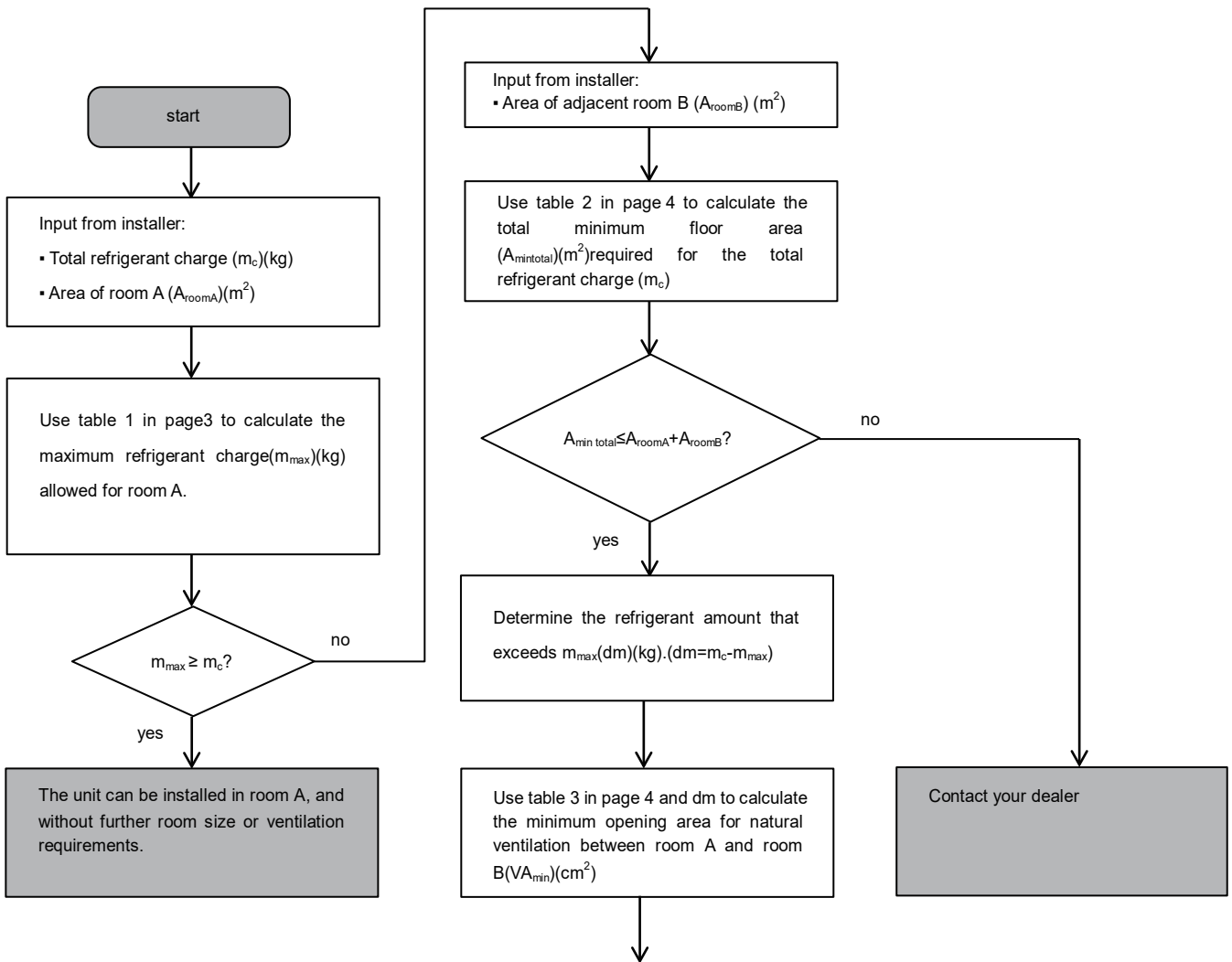

Unit can be installed at room A if:

- 2 ventilation openings (permanently open) are provided between room A and B, 1 at the top and 1 at the bottom.
- Bottom opening : The bottom opening must meet the minimum area requirements (VA_{min}). It must be as close as possible to the floor. If the ventilation opening starts from the floor, the height must be ≥ 20 mm. The bottom of the opening must be situated ≤ 100 mm from the floor. At least 50 % of the required opening area must be situated < 200 mm from the floor. The entire area of the opening must be situated < 300 mm from the floor.
- Top opening : The area of the top opening must be larger than or equal to the bottom opening. The bottom of the top opening must be situated at least 1.5 m above the top of the bottom opening.
- Ventilation openings to the outside are NOT considered suitable ventilation openings (the user can block them when it is cold).

Table 1-Maximum refrigerant charge allowed in a room:indoor unit

$A_{room}(m^2)$	Maximum refrigerant charge in a room(m_{max})(kg)		$A_{room}(m^2)$	Maximum refrigerant charge in a room(m_{max})(kg)	
	H = 1 230 mm(100/190)			H = 1 500 mm(100/240,160/240)	
6.9	1.85		4.7	1.85	
7.0	1.87		5.0	1.93	
8.0	1.98		5.5	2.01	
9.0	2.13		6.0	2.10	
10.0	2.23		6.5	2.19	
11.0	2.34		7.0	2.27	
12.0	2.44		7.5	2.34	
			8.0	2.44	

Table 2-Minimum floor area:indoor unit

m _c (kg)	Minimum floor area(m ²)	
	H = 1 230 mm(100/190)	H = 1 500 mm(100/240,160/240)
1.85	6.90	4.70
1.90	7.31	4.92
1.95	7.70	5.18
2.00	8.10	5.45
2.05	8.51	5.72
2.10	8.93	6.01
2.15	9.36	6.30
2.20	9.80	6.59
2.25	10.3	6.89
2.30	10.7	7.20
2.35	11.2	7.52
2.40	11.7	7.84
2.45	12.2	8.10

Table 3-Minimum venting opening area for natural ventilation: indoor unit

m _c	m _{max}	dm=m _c -m _{max} (kg)	Minimum venting opening area(cm ²)	
			H = 1 230 mm(100/190)	H = 1 500 mm(100/240,160/240)
2.41	0.3	2.11	375	290
2.41	0.5	1.91	350	280
2.41	0.7	1.71	330	268
2.41	0.9	1.51	315	258
2.41	1.1	1.31	302	247
2.41	1.3	1.11	278	228
2.41	1.5	0.91	245	200
2.41	1.7	0.71	203	167
2.41	1.9	0.51	154	126
2.41	2.1	0.31	98	80

DANGER

- Before touching electric terminal parts, turn off power switch.
- When service panels are removed, live parts can be easily touched by accident.
- Never leave the unit unattended during installation or servicing when the service panel is removed.
- Do not touch water pipes during and immediately after operation as the pipes may be hot and could burn your hands. To avoid injury, give the piping time to return to normal temperature or be sure to wear protective gloves.
- Do not touch any switch with wet fingers. Touching a switch with wet fingers can cause electrical shock.
- Before touching electrical parts, turn off all applicable power to the unit.

WARNING

- Tear apart and throw away plastic packaging bags so that children will not play with them.Children playing with plastic bags face danger of death by suffocation.
- Safely dispose of packing materials such as nails and other metal or wood parts that could cause injuries.
- Ask your dealer or qualified personnel to perform installation work in accordance with this manual. Do not install the unit by yourself. Improper installation could result in water leakage, electric shocks or fire
- Be sure to use only specified accessories and parts for installation work. Failure to use specified parts may result in water leakage, electric shocks, fire, or the unit falling from its mount.
- Install the unit on a foundation that can withstand its weight. Insufficient physical strength may cause the equipment to fall and possible injury.
- Perform specified installation work with full consideration of strong wind, hurricanes, or earthquakes. Improper installation work may result in accidents due to equipment falling.

- Make certain that all electrical work is carried out by qualified personnel according to the local laws and regulations and this manual using a separate circuit. Insufficient capacity of the power supply circuit or improper electrical construction may lead to electric shocks or fire.
- Be sure to install a earth fault circuit interrupter according to local laws and regulations. Failure to install a earth fault circuit interrupter may cause electric shocks and fire.
- Make sure all wiring is secure. Use the specified wires and ensure that terminal connections or wires are protected from water and other adverse external forces. Incomplete connection or affixing may cause a fire.
- When wiring the power supply, form the wires so that the front panel can be securely fastened. If the front panel is not in place there could be overheating of the terminals, electric shocks or fire.
- After completing the installation work, check to make sure that there is no refrigerant leakage.
- Never directly touch any leaking refrigerant as it could cause severe frostbite. Do not touch the refrigerant pipes during and immediately after operation as the refrigerant pipes may be hot or cold, depending on the condition of the refrigerant flowing through the refrigerant piping, compressor and other refrigerant cycle parts. Burns or frostbite are possible if you touch the refrigerant pipes. To avoid injury, give the pipes time to return to normal temperature or, if you must touch them, be sure to wear protective gloves.
- Do not touch the internal parts (pump, backup heater, etc.) during and immediately after operation. Touching the internal parts can cause burns. To avoid injury, give the internal parts time to return to normal temperature or, if you must touch them, be sure to wear protective gloves.

CAUTION

- Earth the unit.
- Earthing resistance should be according to local laws and regulations.
- Do not connect the earth wire to gas or water pipes, lightning conductors or telephone earth wires.
- Incomplete earthing may cause electric shocks.
 - Gas pipes: Fire or an explosion might occur if the gas leaks.
 - Water pipes: Hard vinyl tubes are not effective earths.
 - Lightning conductors or telephone earth wires : Electrical threshold may rise abnormally if struck by a lightning bolt.

CAUTION

- Install the power wire at least 3 feet (1 meter) away from televisions or radios to prevent interference or noise. (Depending on the radio waves, a distance of 3 feet (1 meter) may not be sufficient to eliminate the noise.)
- Do not wash the unit. This may cause electric shocks or fire. The appliance must be installed in accordance with national wiring regulations. If the supply cord is damaged, it must be replaced by the manufacturer, its service agent or similarly qualified persons in order to avoid a hazard.
- Do not install the unit in the following places:
 - Where there is mist of mineral oil, oil spray or vapors. Plastic parts may deteriorate, and cause them to come loose or water to leak.
 - Where corrosive gases (such as sulphurous acid gas) are produced. Where corrosion of copper pipes or soldered parts may cause refrigerant to leak.
 - Where there is machinery which emits electromagnetic waves. Electromagnetic waves can disturb the control system and cause equipment malfunction.
 - Where flammable gases may leak, where carbon fiber or ignitable dust is suspended in the air or where volatile flammables such as paint thinner or gasoline are handled. These types of gases might cause a fire.
 - Where the air contains high levels of salt such as near the ocean.
 - Where voltage fluctuates a lot, such as in factories.
 - In vehicles or vessels.
 - Where acidic or alkaline vapors are present.
- This appliance can be used by children 8 years old and above and persons with reduced physical, sensory or mental capabilities or lack of experience and knowledge if they are supervised or given instruction on using the unit in a safe manner and understand the hazards involved. Children should not play with the unit. Cleaning and user maintenance should not be done by children without supervision.
- Children should be supervised to ensure that they do not play with the appliance.
- If the supply cord is damaged, it must be replaced by the manufacturer or its service agent or a similarly qualified person.
- DISPOSAL: Do not dispose this product as unsorted municipal waste. Collection of such waste separately for special treatment is necessary. Do not dispose of electrical appliances as municipal waste, use separate collection facilities. Contact your local government for information regarding the collection systems available. If electrical appliances are disposed of in landfills or dumps, hazardous substance can leak into the groundwater and get into the food chain, damaging your health and well-being.

- The wiring must be performed by certified person technicians in accordance with national wiring regulation and this circuit diagram. An all-pole disconnection device which has at least 3 mm separation distance in all pole and a residualcurrent device(RCD) with the rating not exceeding 30 mA shall be incorporated in the fixed wiring according to the national rule.
- Confirm the safety of the installation area (walls, floors, etc.) without hidden dangers such as water, electricity, and gas before wiring/pipes.
- Before installation , check whether the user's power supply meets the electrical installation requirements of unit (including reliable earthing , leakage , and wire diameter electrical load, etc.). If the electrical installation requirements of the product are not met, the installation of the product is prohibited until the product is rectified.
- Product installation should be fixed firmly, Take reinforcement measures, when necessary.

CAUTION

- About Fluorinated Gases
 - This air-conditioning unit contains fluorinated gases. For specific information on the type of gas and the amount, please refer to the relevant label on the unit itself. Compliance with national gas regulations shall be observed.
 - Installation, service, maintenance and repair of this unit must be performed by a certified technician.
 - Product uninstallation and recycling must be performed by a certified technician.
 - If the system has a leak-detection system installed, it must be checked for leaks at least every 12 months. When the unit is checked for leaks, proper record-keeping of all checks is strongly recommended.

3 BEFORE INSTALLATION

• Before installation

Be sure to confirm the model name and the serial number of the unit.

CAUTION

Frequency of Refrigerant Leakage Checks

- For unit that contains fluorinated greenhouse gases in quantities of 5 tonnes of CO₂ equivalent or more, but of less than 50 tonnes of CO₂ equivalent, at least every 12 months, or where a leakage detection system is installed, at least every 24 months.
- For unit that contains fluorinated greenhouse gases in quantities of 50 tonnes of CO₂ equivalent or more, but of less than 500 tonnes of CO₂ equivalent, at least every six months, or where a leakage detection system is installed, at least every 12 months.
- For unit that contains fluorinated greenhouse gases in quantities of 500 tonnes of CO₂ equivalent or more, at least every three months, or where a leakage detection system is installed, at least every six months.
- This air-conditioning unit is a hermetically sealed equipment that contains fluorinated greenhouse gases.
- Only certificated person is allowed to do installation, operation and maintenance.

4 INSTALLATION SITE

WARNING

- There is flammable refrigerant in the unit and it should be installed in a well-ventilated site. If the unit is installed inside, an additional refrigerant detection device and ventilation equipment must be added in accordance with the standard EN378. Be sure to adopt adequate measures to prevent the unit from being used as a shelter by small animals.
- Small animals making contact with electrical parts can cause malfunction, smoke or fire. Please instruct the customer to keep the area around the unit clean.
- The equipment is not intended for use in a potentially explosive atmosphere.

- Select an installation site where the following conditions are satisfied and one that meets with your customer's approval.
 - Places that are well-ventilated.
 - Safe places which can bear the unit's weight and vibration and where the unit can be installed at an even level.
 - Places where there is no possibility of flammable gas or product leak.
 - The equipment is not intended for use in a potentially explosive atmosphere.
 - Places where servicing space can be well ensured.
 - Places where the units' piping and wiring lengths come within the allowable ranges.
 - Places where water leaking from the unit cannot cause damage to the location (e.g. in case of a blocked drain pipe).
 - Do not install the unit in places often used as a work space. In case of construction work (e.g. grinding etc.) where a lot of dust is created, the unit must be covered.
 - Do not place any object or equipment on top of the unit (top plate)
 - Do not climb, sit or stand on top of the unit.
 - Be sure that sufficient precautions are taken in case of refrigerant leakage according to relevant local laws and regulations.

 **CAUTION**

The indoor unit should be installed in an indoor water proof place, or the safety of the unit and the operator cannot be ensured.

The indoor unit is to be wall mounted in an indoor location that meets the following requirements:

- The installation location is frost-free.
- The space around the unit is adequate for serving, see figure 6-2.
- The space around the unit allows for sufficient air circulation.
- There is a provision for condensate drain and pressure relief valve blow-off.

 **CAUTION**

When the unit running in the cooling mode, condensate may drop from the water inlet and water outlet pipes. Please make sure the dropping condensate will not result in damage of your furniture and other devices.

- The installation surface is a flat and vertical non-combustible wall, capable of supporting the operation weight of the unit.
- All piping lengths and distance have been taken into consideration.

Table 4-1

Requirement	Value
Maximum allowable piping length between the 3-way valve SV1 and the indoor unit (only for installations with domestic hot water tank)	3 m
Maximum allowable piping length between the domestic hot water tank and the indoor unit (only for installations with domestic hot water tank). The temperature sensor cable supplied with the indoor unit is 10 m in length.	8 m
Maximum allowable piping length between the TW2 and the indoor unit. The temperature sensor a cable of TW2 supplied with the indoor unit is 10 m in length.	8 m

5 ACCESSORIES

5.1 Unpacking

Removing the package

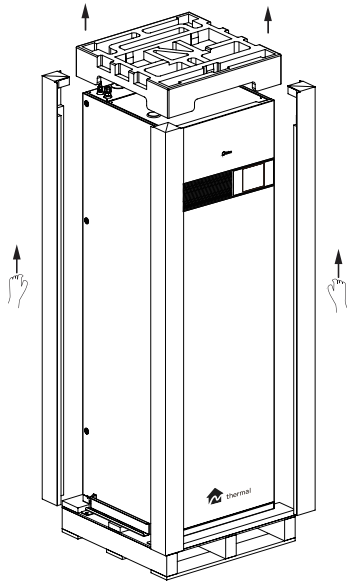

Fig.5-1

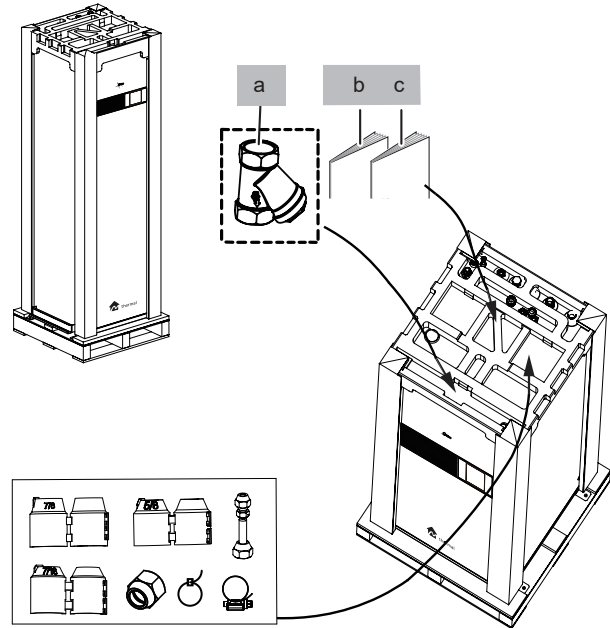

Fig.5-2

Installation Fittings					Installation Fittings				
Name	Shape	Quantity			Name	Shape	Quantity		
		100/190	100/240	160/240			100-190	100-240	160-240
Installation And Owner's Manual(This Book)		1	1	1	M9 Copper Flare Nut		1	1	1
					M16 Copper Flare Nut		1	1	1
M16 Copper Flare Nut Insulation Accessories		1	1	1	Y-Type Strainer		1	1	1
M9 Copper Flare Nut Insulation Accessories		1	1	1	Operation Manual (Wire Controller)		1	1	1
M6 Copper Flare Nut Insulation Accessories		1	1	1	Adapter 9.52-6.35		1	1	1
					Cable Tie L200		2	2	2
					Clamp		1	1	1

Accessories Available From Supplier		
Thermistor for Balance Tank(Tbt1)		1
Extension Wire for Tbt1		1
Thermistor for Zone 2 Flow Temp.(Tw2)		1
Extension Wire for Tw2		1

5.2 Remove the shipping pallet

- Remove the 4 screws of the wooden base(Refer to Fig.5-3).
- Four people hold the sheet metal lifting machine,one of them pull the wooden base(Refer to Fig.5-4).
- Remove the 8 screws of the sheet metal and remove the sheet metal(Refer to Fig.5-5).
- Take carefully when lifting machine and pull the wooden.
- Care should be taken when transporting the heat pump unit that the casing is not damaged by impact. Do not remove the protective packaging unit heat pump unit has reached its final location.This will help protect the structure and control panel.The heat pump unit can be transported ONLY vertically.
- Be careful with the Installation and Operation manual and with the factory-supplied accessories box located at the top of the unit.
- Four people are required when lifting because of the heavy weight of the unit.

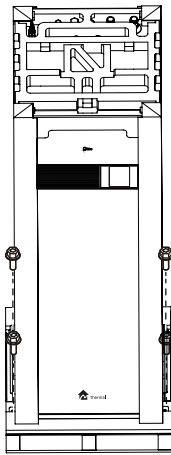

Fig.5-3

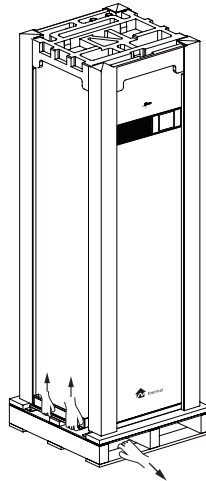

Fig.5-4

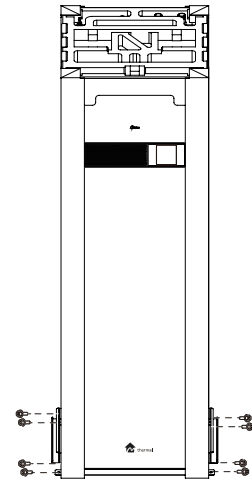

Fig.5-5

INSTALLATION SITE

⚠ WARNING

- Do not install the IDU near a bedroom;
 - Suggest install it in a garage, utility room, corridor, basement, or laundry room;
 - Be sure to adopt adequate measures to prevent the unit from being used as a shelter by small animals.
 - Small animals making contact with electrical parts can cause malfunction, smoke or fire. Please instruct the customer to keep the area around the unit clean.
 - The equipment is not intended for use in a potentially explosive atmosphere.
 - Please connect the top pipe or fill the water tank immediately after removing the wooden frame, so as not to cause the machine to tip over.
- Select an installation site where the following conditions are satisfied and one that meets with your customer's approval.
 - Safe places which can bear the unit's weight and where the unit can be installed at an even level.
 - Places where there is no possibility of flammable gas or product leak.
 - The equipment is not intended for use in a potentially explosive atmosphere.
 - Places where servicing space can be well ensured.
 - Places where the units' piping and wiring lengths come within the allowable ranges.
 - Places where water leaking from the unit cannot cause damage to the location (e.g. in case of a blocked drain pipe).
 - Do not install the unit in places often used as a work space. In case of construction work (e.g. grinding etc.) where a lot of dust is created, the unit must be covered.
 - Do not place any object or equipment on top of the unit (top plate)
 - Do not climb, sit or stand on top of the unit.
 - Be sure that sufficient precautions are taken in case of refrigerant leakage according to relevant local laws and regulations.
 - Don't install the unit near the sea or where there is corrosion gas.
 - When installing the unit in a place exposed to strong wind, pay special attention to the following.
In normal condition, refer to the figures below for installation of the unit:

⚠ CAUTION

The indoor unit should be installed in an indoor water proof place.

The indoor unit is to be floor mounted in an indoor location that meets the following requirements:

- The installation location is frost-free.
- The space around the unit is adequate for serving(Refer to Fig.6-2).
- There is a provision for condensate drain and pressure relief valve blow-off.

⚠ CAUTION

When the unit is running in the cooling mode, condensate may drop from the water inlet and water outlet pipes. Please make sure the dropping condensate will not result in damage of your furniture and other devices.

6 INSTALLATION

6.1 Dimensions of the unit:

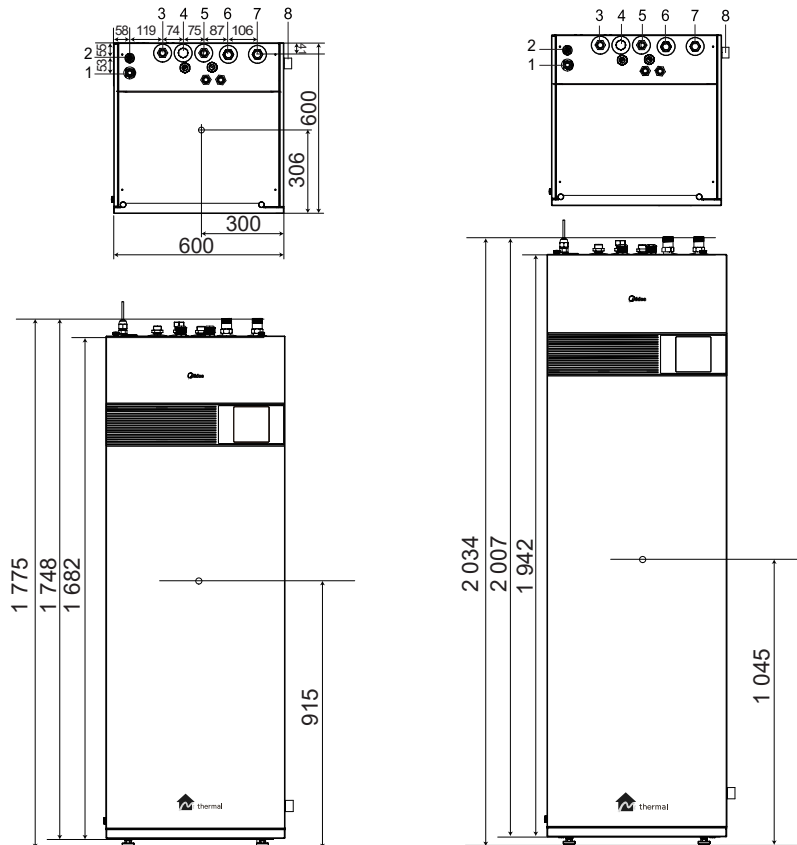

Fig.6-1

unit:mm

NO.	NAME	NO.	NAME
1	Refrigerant gas connection 5/8"-14UNF	5	Domestic cold water inlet
2	Refrigerant liquid connection 3/8" -14 UNF	6	Space heating (cooling) water inlet .R1"
3	Domestic hot water outlet R3/4"	7	Space heating (cooling) water outlet .R1"
4	Domestic hot water recirculation water inlet (Plugged by the nut).	8	Drainage \varnothing 25

- The content in the dotted line area is for customized.

6.2 Installation requirements

- The indoor unit is packed by the carton cap and corner.
- At delivery, the unit must be checked and any damage must be reported immediately to the carrier claims agent.
- Check if all indoor unit accessories are enclosed.
- Bring the unit as close as possible to the final installation position in its original package in order to prevent damage during transport.
- When the water tank is free of water, the maximum net weight of indoor unit with, water tank shall reach about 158kg, which needs to be lifted by special equipment.

⚠ WARNING

Do not grasp the control box or pipe to lift the unit!

6.3 Servicing space requirements

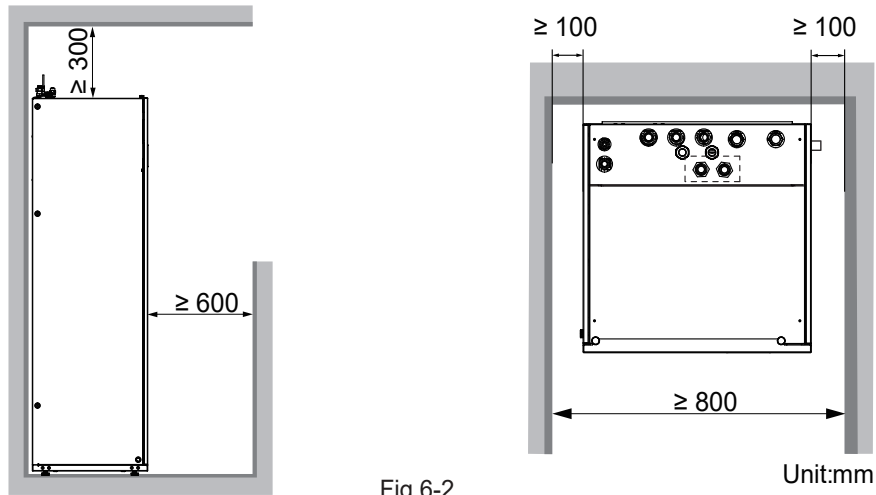

Fig.6-2

6.4 Mounting the indoor unit

⚠ CAUTION

Ensure that apparatus is mounted securely.

Lift the indoor unit from the pallet and place it on the floor.
Slide the indoor unit into position.

Adjust the height of the leveling feet (Refer to Fig.6-3) to compensate for floor irregularities. The maximum allowed deviation is 1° (Refer to Fig. 6-4)

Be specially careful with the mounting foot once the unit is on the floor. Avoid harsh handling of the unit, as it could cause damages to the foot.

Each mounting feet can be adjusted up to 30mm, but keep all them in the factory supplied position unit has been installed in its final position.

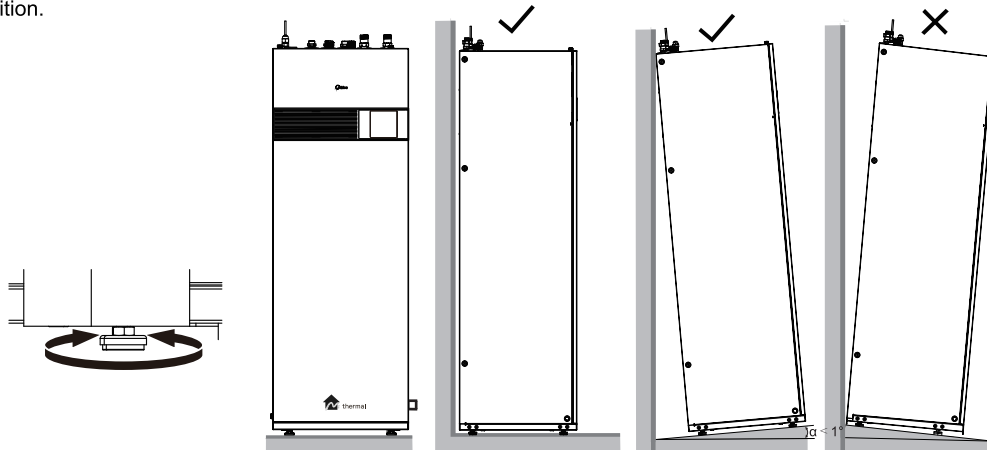

Fig.6-3

Fig.6-4

6.5 Connecting the refrigerant piping

For all guidelines, instructions and specifications regarding refrigerant pipe between the indoor unit and outdoor unit, please refer to "Installation and owner's manual" (M-thermal split outdoor unit).

Connecting the 16mm refrigerant pipe to the refrigerant gas connection.

- Sufficiently tighten the flare nut (Refer to Fig.6-7)
- Check the tightening torque (Refer to the right table) .
- Tighten it with a spanner and torque wrench (Refer to Fig.6-8)
- The protective nut is a one-time part, it can not be reused. In case it is removed, it should be replaced with a new one. (Refer to Fig.6-9)

Outer diam.	Tightening torque(N·cm)	Additional tightening torque(N·cm)
φ 6.35	1 500 (153 kgf.cm)	1 600 (163 kgf.cm)
φ 9.52	2 500 (255 kgf.cm)	2 600 (265 kgf.cm)
φ 16	4 500 (459 kgf.cm)	4 700 (479 kgf.cm)

⚠ CAUTION

- When connecting the refrigerant pipes, always use two wrenches/spanners to tighten or loosen the nuts! (Refer to Fig.6-8) Otherwise, it will cause damage of piping connections and leakage .
- If the indoor unit is matched with outdoor unit (4/6 kW), the transfer 9.52-6.35(Refer to the table in Page 8) should be mounted on the refrigerant liquid connection of indoor unit(Refer to Fig.6-6); The transfer is not used in other types of outdoor unit(8/10/12/14/16 kW).

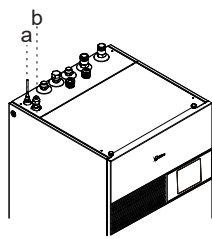

Fig.6-5

a Refrigerant liquid connection
b Refrigerant gas connection

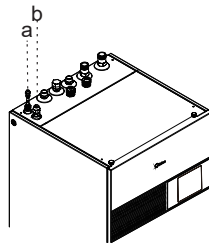

Fig.6-6

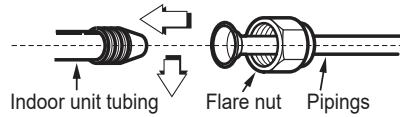
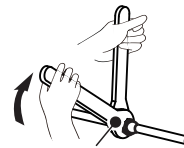

Fig.6-7



Torque wrench
Fig.6-8

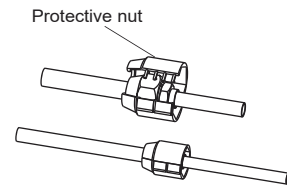

Fig.6-9

CAUTION

- Under installation conditions, excessive torque can damage the nut.
- When flared joints are reused, the flare part should be re-fabricated.
- Under no circumstances shall potential sources of ignition be used in the searching for or detection of refrigerant leaks. A halide torch (or any other detector using a naked flame) shall not be used.
- Leak detection fluids are suitable for use with most refrigerants but the use of detergents containing chlorine shall be avoided as the chlorine may react with the refrigerant and corrode the copper pipe-work.
- Electronic leak detectors shall be used to detect flammable refrigerants, but the sensitivity may not be adequate, or may need re-calibration. (Detection equipment shall be calibrated in a refrigerant-free area.) Ensure that the detector is not a potential source of ignition and is suitable for the refrigerant used. Leak detection equipment shall be set at a percentage of the LFL of the refrigerant and shall be calibrated to the refrigerant employed and the appropriate percentage of gas (25 % maximum) is confirmed.
- Adapter 9.52-6.35 is single-use only.

7 GENERAL INTRODUCTION

- These units are used for both heating and cooling applications and domestic hot water. They can be combined with fan coil units, floor heating applications, low temperature high efficiency radiators.
- A wired controller is supplied with the unit.
- The backup heater can increase the heating capacity during cold outdoor temperatures. The backup heater also serves as a backup in case of malfunctioning and for frozen protection of the outside water piping during winter time.

NOTE

- Maximum length of communication wirings between the indoor unit and the controller is 50 m.
- Power cords and communication wiring must be laid out separately, they can not be placed in the same conduit. Otherwise, it may lead to electromagnetic interference. Power cords and communication wirings should not come in contact with the refrigerant pipe so as to prevent the high temperature pipe from damaging wirings.
- Communication wirings must use shielded lines. Including indoor unit to outdoor unit PQE line, indoor unit to controller ABXYE line.

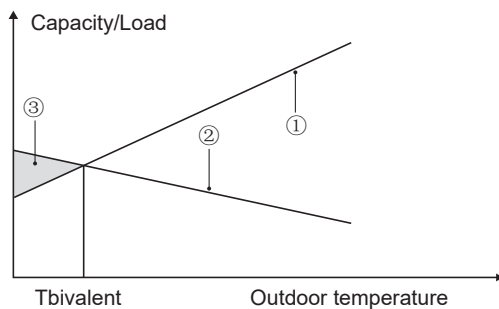

- ① Heat pump capacity.
- ② Required heating capacity (site dependent).
- ③ Additional heating capacity provided by backup heater.

Room thermostat(field supply)

Room thermostat can be connected to the unit(room thermostat should be kept away from heating source when selecting the installation place).

Operation range

Operation range of indoor unit		
Water pressure		0.1~0.3 MPa
Water flow	100	0.40~2.10 m ³ /h
	160	0.70~3.00 m ³ /h

The unit have a freeze prevention function that uses the heat pump or backup heater to keep the water system safe from freezing in all conditions. Since a power failure may happen when the unit is unattended, It's suggested to use anti-freezing flow switch in the water system. (Refer to 8.7 "Water circuit anti-freeze protection").

The water flowing temperature (TW_out) range in different outdoor temperature (T4) for different mode is list below:

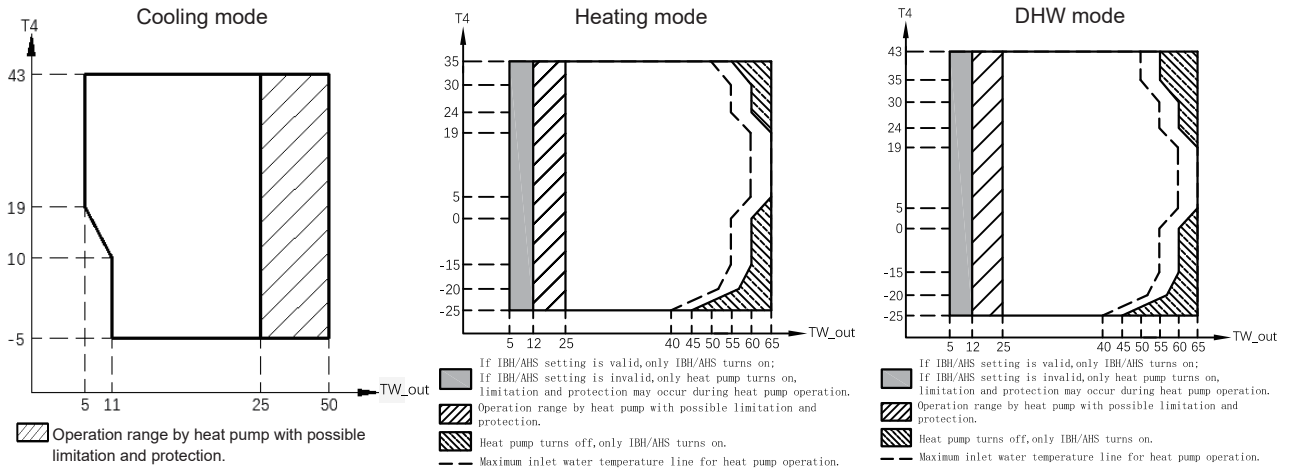

8 CONNECTING THE WATER PIPING

8.1 Connecting the space heating(cooling)water piping

To facilitate service and maintenance, two shut-off valves(field supply) and one overpressure bypass valve should be installed.

The two shut-off valves should be mounted on the space heating (cooling)water inlet and outlet pipe of indoor unit.

- 1.Connecting the shut-off valves to the indoor units.
- 2.Connecting the shut-off valves to the space heating(cooling) water pipes.

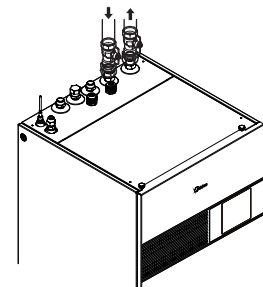

Fig. 8-1

8.2 Connecting the domestic water piping

The shut-off valve should be mounted on the domestic cold water inlet.

- 1.Connect the shut-off valve to the cold water inlet of indoor unit.
- 2 Connect the cold water pipe to the shut-off valve.
- 3 Connect the domestic hot water pipe to the hot water outlet of indoor unit.

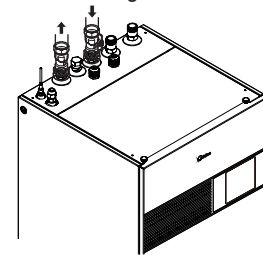
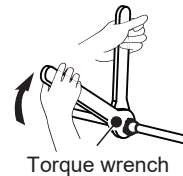

Fig. 8-2

8.3 Connecting the recirculation water piping

If domestic hot water recirculation function is requested,the recirculation pipe should be connected

- 1.Removing the nut of the recirculation on the indoor unit.
- 2.Connecting the recirculation water pipe to the indoor unit.
- 3.Check the tightening torque (Refer to the right table) .
- 4.Tighten it with a spanner and torque wrench.



Torque wrench

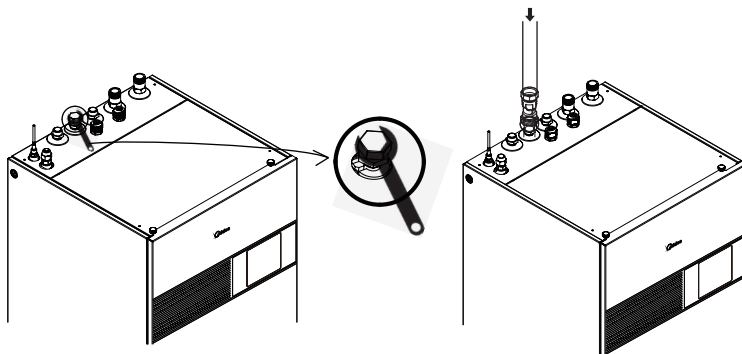

Fig.8-3

Fig.8-4

Outer diam.	Tightening torque(N·cm)	Additional tightening torque(N·cm)
φ 6.35	1 500 (153 kgf·cm)	1 600 (163 kgf·cm)
φ 9.52	2 500 (255 kgf·cm)	2 600 (265 kgf·cm)
φ 16	4 500 (459 kgf·cm)	4 700 (479 kgf·cm)

8.4 Connecting the drainage hose to the indoor unit

The water coming from the pressure relief valve and the condensate water is collected in the drainage pan.

The drainage hose should be connected to the drainage pipe.

Connect the drainage pipe with a throat bander and insert the drainage pipe into the floor drain.

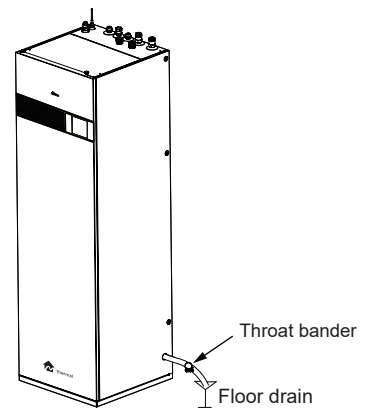

Fig.8-5

8.5 Water piping insulation

The insulation materials should be covered on the all piping in the water circuit piping system to prevent condenser water during cooling operation, the capacity reduction and freezing of the outside water piping during winter. The insulation material should be at least of B1 fire resistance rating and complies with all applicable legislation. The thickness of the sealing materials must be at least 13 mm with thermal conductivity 0.039 W/mK in order to prevent freezing on the outside water piping.

If the outside temperature is higher than 30 °C and the humidity is higher than RH 80 %, Then the thickness of the insulation materials should be at least 20 mm in order to avoid condensation on the surface of the insulation piping.

8.6 Water volume and sizing expansion vessels

The units are equipped with an expansion vessel of 8 L (effective volume is 5 L, use effective volume for calculation) that has a default pre-pressure of 1.0 bar.

1) Check that the total water volume in the installation, excluding the internal water volume of the unit, is at least 40 L. See 14 "Technical specifications" to find the total internal water volume of the unit.

2) When the capacity of the integrated expansion vessel is insufficient for the system due to high water volume, an additional expansion vessel (supplied by the user) is needed.

Refer to the formula below to determine the specification of the additional expansion vessel.

System with only water	System with 35 % glycol
$V_2 = \frac{4C * 0.01979 - V_1 * (3 - P_{g1})}{3 - P_{g2}}$	$V_2 = \frac{4C * 0.01373 - V_1 * (3 - P_{g1})}{3 - P_{g2}}$

V2: Additional expansion vessel volume, in L;

V1: Integrated expansion vessel volume, in L, 5 L;

C: System water volume, in L;

Pg2: Additional expansion vessel Pre-pressure (relative pressure), in bar.

Pg1: Integrated expansion vessel Pre-pressure (relative pressure), in bar, 1 bar.

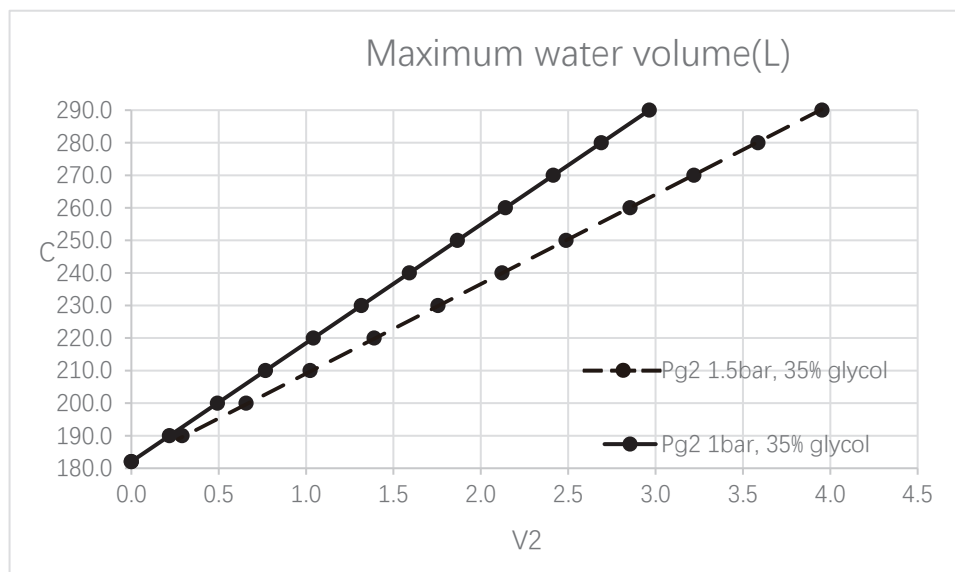
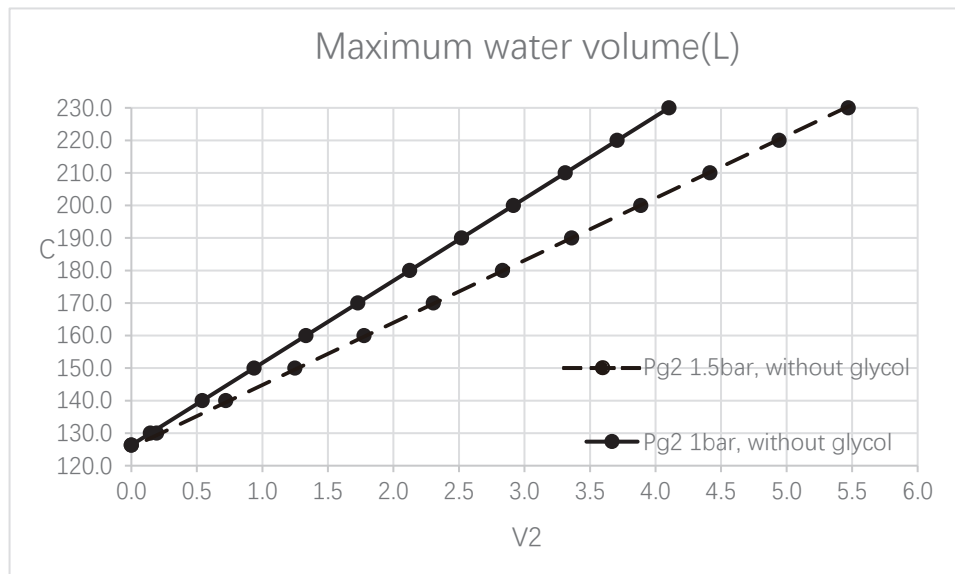

8.7 Water circuit anti-freeze protection

All hydronic parts inside of the unit are insulated to reduce the heat loss. Insulation materials must be added on the field water piping.

The unit program has special functions which use the heat pump and backup heater (if available) to protect the entire system from freezing. When the temperature of the water flow in the system drops to a certain value, the unit will heat the water by using the heat pump or the electric heating tap or the backup heater. The anti-freeze protection function will turn off only when the temperature increases to a certain value.

When unit lose the power, the above function will not active to protect the unit from freezing.

⚠ CAUTION

When the unit is not running for a long time, make sure the unit is powered on all the time. If the unit should be cut off the power, make sure the water in the piping of the system should be drained completely to avoid the water pump and piping system being damaged by freezing. The power of the unit also needs to be cut off after water in the system is drained.

Water may enter into the flow switch and cannot be drained out, it may freeze when the temperature is low enough. The flow switch should be removed and dried, then can be reinstalled in the unit.

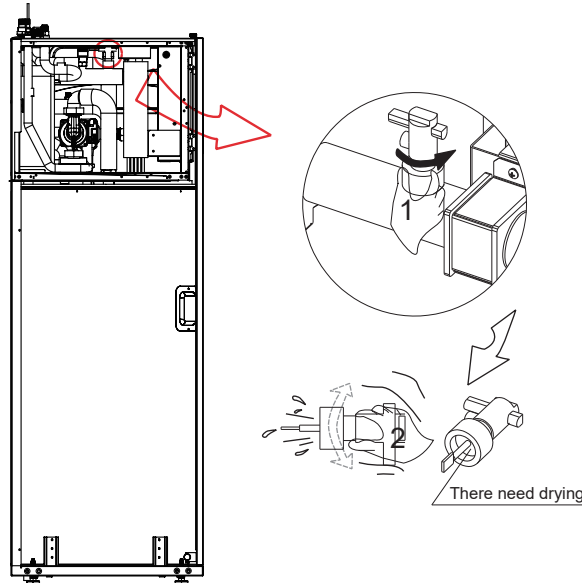

Fig.8-6

💡 NOTE

1. Counterclockwise rotation, remove the flow switch.
2. Dry the flow switch completely.

⚠ CAUTION

Be careful not to deform the unit's piping by using excessive force when connecting the piping. Deforming the piping may lead to malfunction of heat pump.

If air, moisture or dust gets in the water circuit, problems may occur. Therefore, always take into account the following when connecting the water circuit:

- Use clean pipes only.
- Hold the pipe end downwards when removing burrs.
- Cover the pipe end when inserting it through a wall to prevent dust and dirt entering.
- Use a good thread sealant for sealing the connections. The sealing must be able to withstand the pressures and temperatures of the system.
 - When using non-copper metallic piping, be sure to insulate two kind of materials from each other to prevent galvanic corrosion.
- As copper is a soft material, use appropriate tools for connecting the water circuit. Inappropriate tools will cause damage to the pipes.

💡 NOTE

The unit is only to be used in a closed water system. Application in an open water circuit can lead to excessive corrosion of the water piping:

- Never use Zn-coated parts in the water circuit. Excessive corrosion of these parts may occur as copper piping is used in the unit's internal water circuit.
- When using a 3-way valve in the water circuit. Preferably choose a ball type 3-way valve to guarantee full separation between the domestic hot water and floor heating water circuit.
- When using a 3-way valve or a 2-way valve in the water circuit. The recommended maximum changeover time of the valve should be less than 60 seconds.

8.8 Water

NOTE

- Circulators function well exclusively with clean and high-quality tap water.
- Risk of material damage due to poor-quality water.
- The most frequent factors that can affect circulators and the system are oxygen, limescale, sludge, acidity level and other substances (including chlorides and minerals).
- In addition to the quality of water, installation also plays an important role. The heating system must be airtight. Choose materials that are not sensitive to oxygen diffusion (risk of corrosion...).

Characteristics of the water

- compliant with local regulations.
- Langelier Index (LI) between 0 and + 0.4.
- within the limits indicated in the chart.

Water quality must be checked by qualified personnel.

Hardness

If the water is hard, install a system suitable to preserve the unit from harmful deposits and limestone formation.

NOTE

If necessary, fit a water softener to reduce water hardness.

Cleanliness

Before connecting the water to the unit, clean the system thoroughly with specific products effective to remove residues or impurities that may affect functioning. Existing systems must be free from sludge and contaminants and protected against buildups.

New systems

In case of new installations, it is essential to wash the entire installation (with the circulator uninstalled) before commissioning the central installation. This removes residues of the installation process (welding, waste, joint products...) and preservatives (including mineral oil). The system must then be filled with clean high-quality tap water.

Existing systems

If a new boiler or heat pump is installed on an existing heating system, the system must be rinsed to avoid the presence of particles, sludge and waste. The system must be drained before installing the new unit. Dirt can be removed only with a suitable water flow. Each section must then be washed separately.

Particular attention must also be paid to "blind spots" where a lot of dirt can accumulate due to the reduced water flow. The system must then be filled with clean high-quality tap water. If, after rinsing, the quality of the water is still unsuitable, a few measures must be taken to avoid problems. An option to remove pollutants is to install a filter. Various types of filters are available. A mesh filter is designed to catch large dirt particles. This filter is usually placed in the part with the larger flow. A tissue filter is designed to catch the finer particles.

Water component for corrosion limit on Copper

PH	7.5 - 9.0	
Electric conductivity	100 - 500	µS/cm
Total Hardness	4.5 – 8.5	dH
Max. quantity glycol	40	%
Sulfate ions (SO ₄)	< 50	ppm
Alkalinity (HCO ₃)	70 - 300	ppm
Chloride ions (Cl ⁻)	< 50	ppm
Phosphates (PO ₄)	< 2.0	ppm
NH ₃	< 0.5	ppm
Iron (Fe)	< 0.3	ppm
Manganese (Mn)	< 0.05	ppm
Sulfate ions (S)	None	
Ammonium ions (NH ₄)	None	
Silica (SiO ₂)	< 30	ppm
CO ₂	< 50	ppm
Oxygen content	< 0.1	ppm
Sand	< 10 mg/L, 0.1 to 0.7 mm max diameter	
Ferrite hydroxide Fe ₃ O ₄ (black)	Dose < 7.5 mg/L, 50 % of mass, with diameter < 10 µm	
Iron oxide Fe ₂ O ₃ (red)	Dose < 7.5 mg/L, diameter < 1 µm	

9 OVERVIEW OF THE UNIT

9.1 Disassembling the unit

The indoor unit cover can be removed by removing the 2 screws and unhitching the cover.

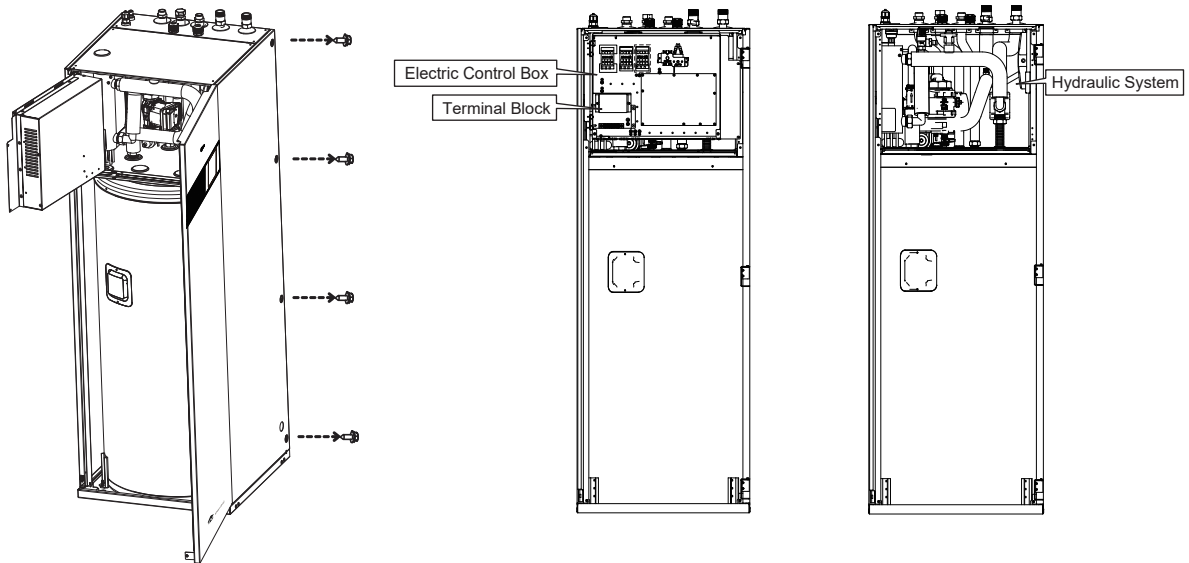

⚠ CAUTION

Make sure to fix the cover with the screws and nylon washers when installing the cover (screws are delivered as accessory). Parts inside the unit can be hot.

- To gain access to the control box components – e.g. to connect the field wiring – the control box service panel can be removed. Thereto, loosen the front screws and unhitch the control box service panel.

⚠ CAUTION

Switch off all power supply – i.e. outdoor unit power supply, indoor unit power supply, electric heater and additional heater power supply – before removing the control box service panel.

9.2 Main components

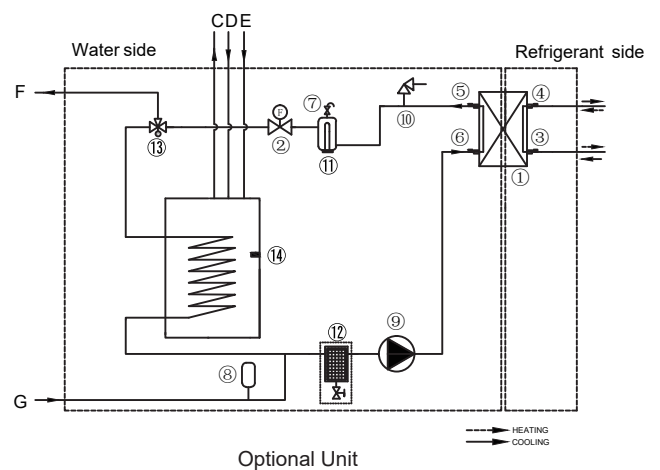
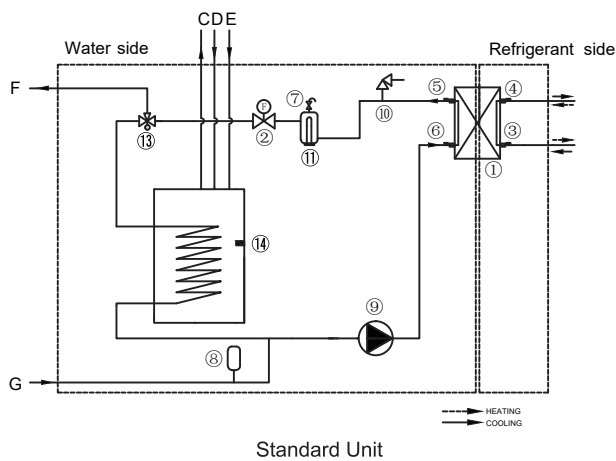

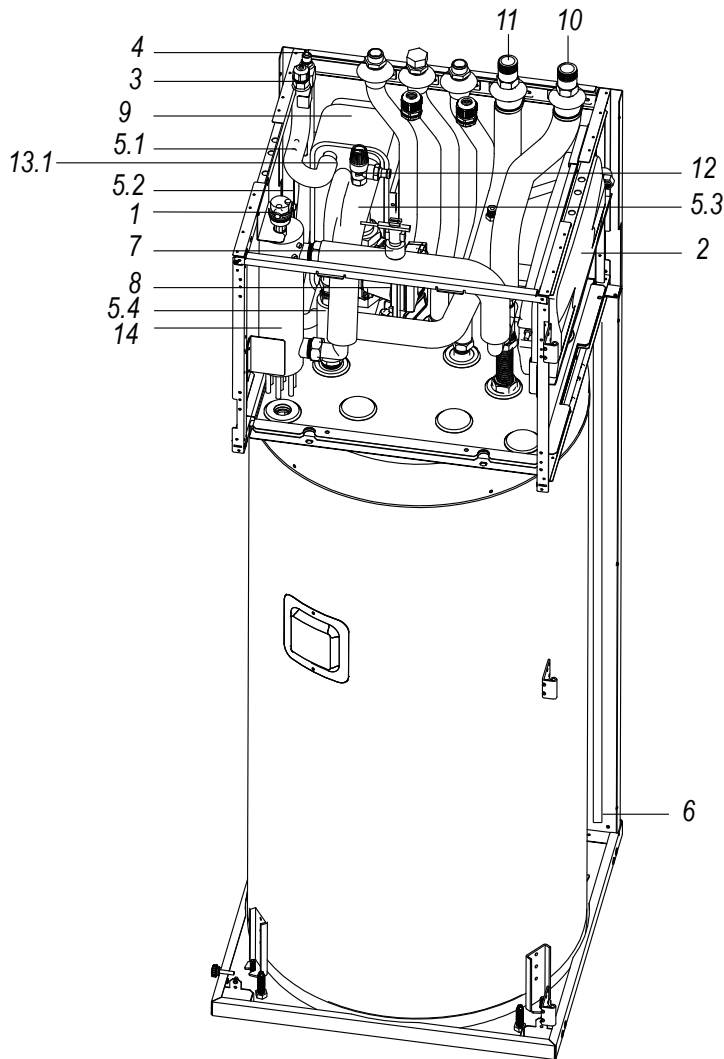

Code	Assembly unit	Description
1	Automatic air purge valve	Remaining air in the water circuit will be automatically removed via the automatic air purge valve.
2	Expansion vessel (8 L)	/
3	Refrigerant gas pipe	/
4	Refrigerant liquid pipe	/
5	Temperature sensors	Four temperature sensors determine the water and refrigerant temperature at various points. 5.1-T2B; 5.2-T2; 5.3-Tw_out; 5.4-Tw_in; 5.5-T1
6	Drainage port	/
7	Flow switch	If water flow is below 0.6 m ³ /h, the flow switch open, then when the water flow reach 0.66 m ³ /h,the flow switch close.
8	Pump_i	The pump circulates the water in the water circuit.
9	Plate heat exchanger	Heat exchanging between water and refrigerant.
10	Water outlet pipe	/
11	Water inlet pipe	/
12	Pressure relief valve	The pressure relief valve prevents excessive water pressure in the water circuit by opening at 43.5 psi(g)/0.3 MPa(g) and discharging some water.
13	Electrical heating belt(13.1-13.2)	They are for preventing frozen.(13.2 is optional)
14	Internal backup heater	The backup heater consists of an electrical heating element that will provide additional heating capacity to the water circuit if the heating capacity of the unit is insufficient due to low outdoor temperatures, it also protects the external water piping from freezing during cold periods.

9.3 Electronic control box

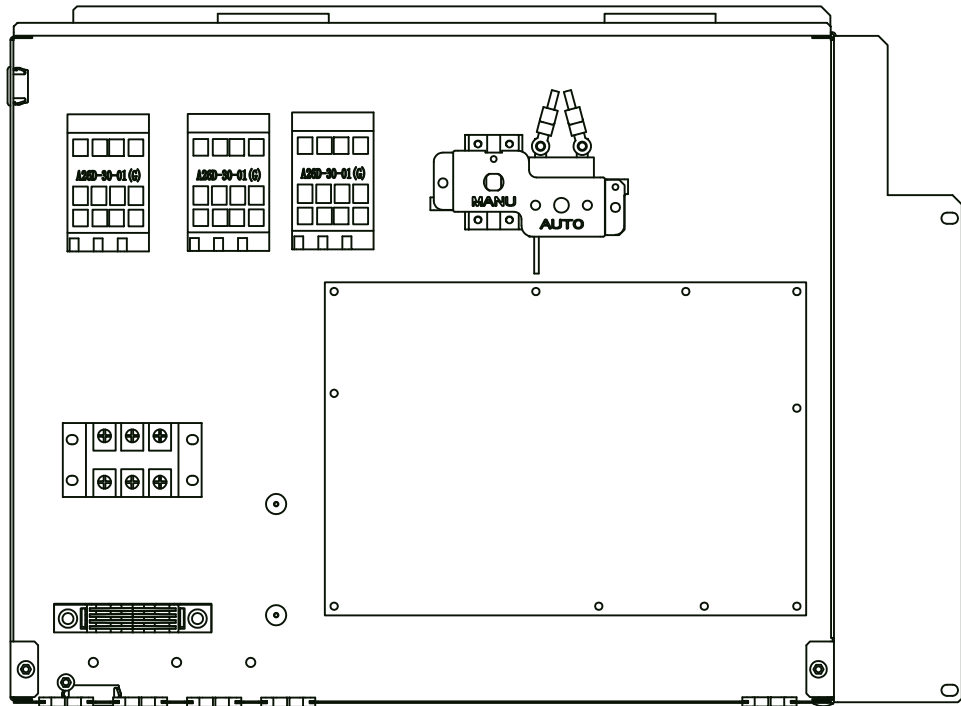

NOTE

The picture is only for reference, please refer to the actual product.

9.3.1 Main control board of indoor unit

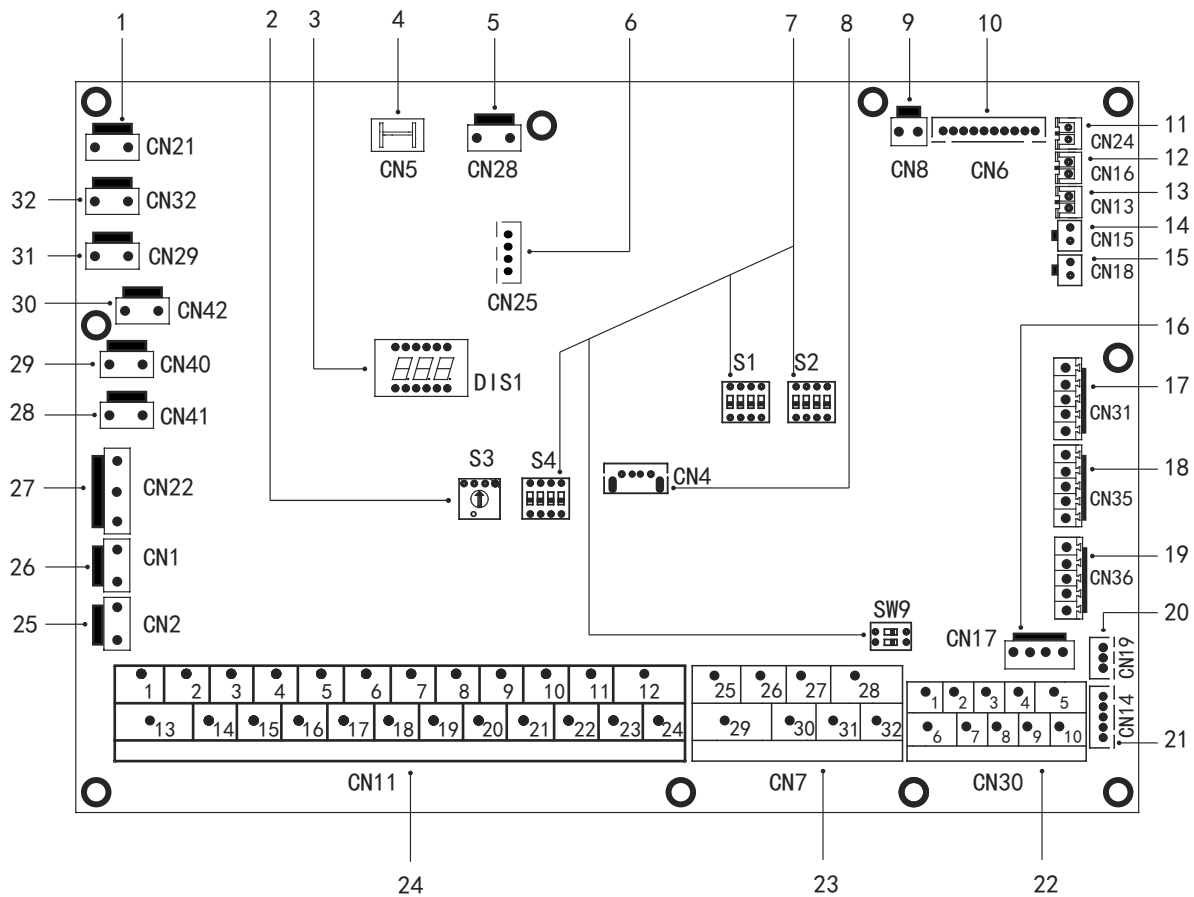

Order	Port	Code	Assembly unit	Order	Port	Code	Assembly unit
1	CN21	POWER	Port for power supply	19	CN36	M1 M2	Port for remote switch
2	S3	/	Rotary dip switch			T1 T2	Port for thermostat transfer board
3	DIS1	/	Digital display	20	CN19	P Q	Communicate port between indoor unit and outdoor unit
4	CN5	GND	Port for earth	21	CN14	A B X Y E	Port for communication with the wired controller
5	CN28	PUMP	Port for variable speed pump power input			1 2 3 4 5	Port for communication with the wired controller
6	CN25	DEBUG	Port for IC programming	22	CN30	6 7	Communicate port between indoor unit and outdoor unit
7	S1,S2,S4,SW9	/	Dip switch			9 10	Port for Internal machine Parallel
8	CN4	USB	Port for USB programming			26 30/31 32	Compressor run/Defrost run
9	CN8	FS	Port for flow switch	23	CN7	25 29	Port for antifreeze E-heating tape(external)
10	CN6	T2	Port for temperature sensor of refrigerant liquid side temperature of indoor unit (heating mode)			27 28	Port for additional heat source
		T2B	Port for temperature sensor of refrigerant gas side temperature of indoor unit (cooling mode)			1 2	Reserved
		TW_in	Port for temperature sensor of inlet water temperature of plate heat exchanger			3 4 15	Port for room thermostat
		TW_out	Port for temperature sensor of outlet water temperature of plate heat exchanger			5 6 16	Port for SV1(3-way valve)
		T1	Port for temperature sensor of final outlet water temperature of indoor unit	24	CN11	7 8 17	Port for SV2(3-way valve)
11	CN24	Tbt1	Port for upper temp. sensor of balance tank			9 21	Port for zone 2 pump
12	CN16	Tbt2	Port for lower temp. sensor of balance tank			10 22	Port for outside circulation pump
13	CN13	T5	Port for domestic hot water tank temp. sensor			11 23	Reserved
14	CN15	Tw2	Port for zone 2 temp.sensor of outlet water			12 24	Port for DHW pipe pump
15	CN18	Tsolar	Reserved	25	CN2	TBH_FB	Control port for tank booster heater
16	CN17	PUMP_BP	Port for variable speed pump communication	26	CN1	IBH1/2_FB	Control port for internal backup heater 1
17	CN31	HT	Control port for room thermostat (heating mode)			13 16	Control port for tank booster heater
		COM	Power port for room thermostat	27	CN22	14 17	Control port for internal backup heater 1
		CL	Control port for room thermostat (cooling mode)			18 19 20	Port for SV3(3-way valve)
18	CN35	SG	Port for smart grid (grid signal)	28	CN41	HEAT8	Feedback port for external temperature switch(shorted in default)
		EVU	Port for smart grid (photovoltaic signal)	29	CN40	HEAT7	Feedback port for temperature switch (shorted in default)
				30	CN42	HEAT6	Control port for internal backup heater 1
				31	CN29	HEAT5	Reserved
				32	CN32	IBH0	Control port for tank booster heater
							Port for anti-freeze electric heating tape(internal)
							Port for anti-freeze electric heating tape(internal)
							Port for anti-freeze electric heating tape(internal)
							Port for anti-freeze electric heating tape(internal)
							Port for backup heater

9.4 Refrigerant pipework

For all guidelines, instructions and specifications regarding refrigerant pipework between the indoor unit and outdoor unit, please refer to "Installation and owner's manual (M-thermal split outdoor unit)".

⚠ CAUTION

When connecting the refrigerant pipes, always use two wrenches/spanners for tightening or loosening nuts! Failure to do so can result in damaged piping connections and leaks.

💡 NOTE

- The appliance contains fluorinated greenhouse gases. Chemical name of the gas: R32
- Fluorinated greenhouse gases are contained in hermetically sealed equipment.
- An electrical switchgear has a tested leakage rate of less than 0.1 % per year as set out in the technical specification of the manufacturer.

9.5 Filling water

9.5.1 Filling the water circuit

- Connect the water supply to the filling valve and open the valve.
- Make sure all the automatic air purge valves are open (at least 2 turns).

- Filling with water until the manometer(field supply) indicates a pressure of approximately 2.0 bar. Remove air in the circuit as much as possible using the automatic air purge valves.

Open the automatic air purge valve, turn counterclockwise at least 2 full turns to release air from the system.

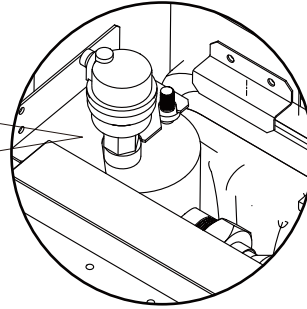

Fig.9-1

NOTE

During filling, it might not be possible to remove all air in the system. Remaining air will be removed through the automatic air purge valve during the first operating hours of the system. Topping up the water afterwards might be required.

- The water pressure indicated on the manometer will vary depending on the water temperature (higher pressure at higher water temperature). However, at all times water pressure should remain above 0.5 bar to avoid air entering the circuit.
- The unit might drain-off too much water through the pressure relief valve.
- Water quality should be complied with EN 98/83 EC Directives.
- Detailed water quality condition can be found in EN 98/83 EC Directives.

NOTE

- In most applications this minimum water volume will be satisfactory.
- In critical processes or in rooms with a high heat load though, extra water might be required.
- When circulation in each space heating loop is controlled by remotely controlled valves, it is important that this minimum water volume is kept even if all the valves are closed.
- if each space heating (cooling loop is controlled by the valves, the overpressure bypass valve(field supply) should be mounted between the heating(cooling) loops.

9.5.2 Filling the domestic hot water tank

- 1.Open every hot water tap in turn to purge air from the pipes of the system.
- 2.Open the cold water supply valve.
- 3.Close all water taps after all air is purged.
- 4.Check for water leakage.
- 5.Manually operate the field-installed pressure relief valve to ensure a free water flow through the discharge pipe.

CAUTION

- Cold water inlet pressure should be less than 1.0MPa. Expansion vessel and safety valve (field supply, protection pressure is 1.0MPa) must be installed.
- Warning and Water Quality Directive and Groundwater: This product is designed to comply with the European Water Quality Directive 98/83/EC amended by 2015/1787/EU. The lifespan of the product is not guaranteed in the case of the use of groundwater, such as spring water or well water, the use of tap water when salt or other impurities are contained, nor in areas of acidic water quality. Maintenance and warranty costs related to these cases are the customer's responsibility.

9.6 TYPICAL APPLICATIONS

9.6.1 Application 1

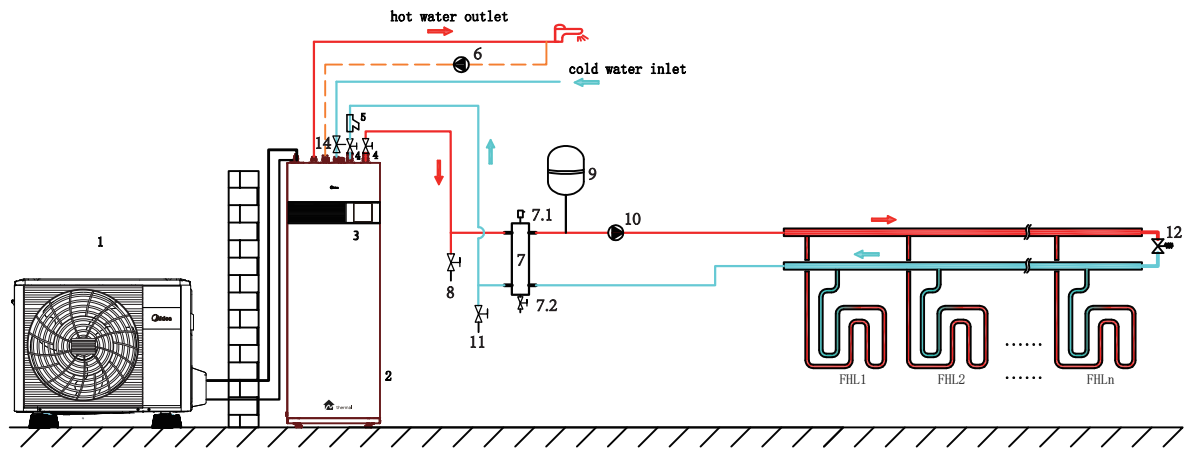

One zone for floor heating loops

9.6.2 Application 2

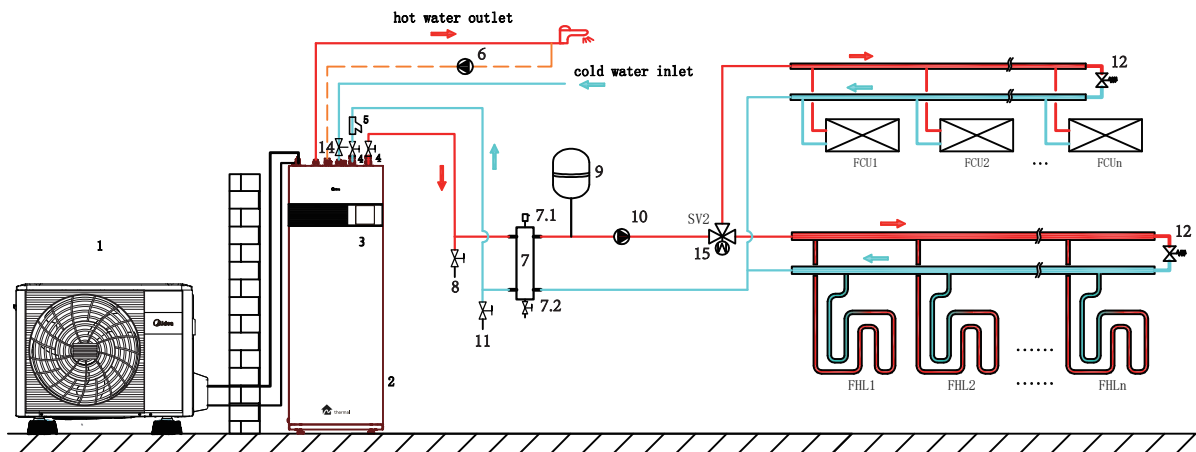

One zone for floor heating loops and fan coil

9.6.3 Application 3

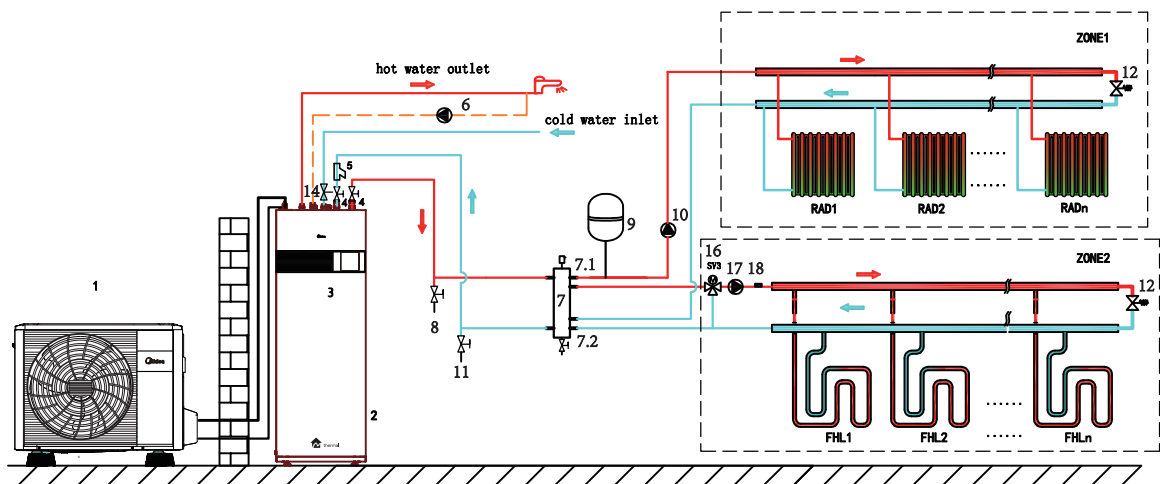

Double zone for floor heating loops and radiators

Code	Assembly unit	Code	Assembly unit
1	Outdoor unit	9	Expansion vessel (Field supply)
2	Indoor unit with tank	10	P_o: Outside circulation pump (Field supply)
3	User interface	11	Filling valve (Field supply)
4	Shut-off valve (Field supply)	12	Bypass valve (Field supply)
5	Filter (Accessory)	13	Plate heat exchanger (Field supply)
6	P_d: DHW circulation pump (Field supply)	14	Pressure relief valve (Field supply)
7	Hydraulic separator	15	SV2: 3 -way valve (Field supply)
7.1	Automatic air purge valve	16	SV3: 3 -way valve (Field supply)
7.2	Drainage valve	17	P_c: zone2 circulation pump (Field supply)
8	Drainage valve (Field supply)	18	Tw2: zone 2 temperature sensor (optional)

Space heating/cooling

One zone application

1) When the unit is ON, P_o keeps running, if unit is OFF, P_o stops running

2) When the unit cooling mode is ON, SV2 keeps OFF

3) When the unit heating mode is ON, SV2 keeps ON,

Double zone application

When zone 1 is ON, P_o keeps running, if zone 1 is OFF, P_o stops running

When zone 2 is ON, P_c keeps running, SV3 switches between ON and OFF according to the Tw2 sensor, if zone 2 is OFF, SV3 keeps OFF, P_c stops running.

The floor heating loops require a lower water temperature in heating mode compared to Radiators or fan coil. To achieve these two set points, a mixing station is used to adapt the water temperature according to requirements of the floor heating loops. The radiators are directly connected to the unit water circuit and the floor heating loops are after the mixing station. The mixing station includes SV3, P_c and Tw2, can be controlled by indoor unit.

Domestic water heating

The ON/OFF signal and target tank water temperature (T5S) are set on the user interface.

P_o/P_c stops running as long as the unit is ON for domestic water heating.

NOTE

1. Install air purge valves at all local high points
2. Drainage valve must be installed at the lowest position of the piping system.
3. A pressure relief valve with an opening pressure of maximum 10 bar (= 1 MPa) must be installed on the domestic cold water inlet connection in accordance with the applicable legislation.

10 FIELD WIRING

WARNING

- If the supply cord is damaged, it must be replaced by the manufacturer, its service agent or similarly qualified persons in order to avoid a hazard.
- The appliance shall be installed in accordance with national wiring regulations. .
- A main switch or other means of disconnection, having a contact separation in all poles, must be incorporated in the fixed wiring in accordance with relevant local laws and regulations. Switch off the power supply before making any connections. Use only copper wires. Never squeeze bundled cables and make sure they do not come in contact with the piping and sharp edges. Make sure no external pressure is applied to the terminal connections. All field wiring and components must be installed by a licensed electrician and must comply with relevant local laws and regulations.
- The field wiring must be carried out in accordance with the wiring diagram supplied with the unit and the instructions given below.
- Be sure to use a dedicated power supply. Never use a power supply shared by another appliance.
- Be sure to establish a earth. Do not earth the unit to a utility pipe, surge protector, or telephone earth. Incomplete earthing may cause electrical shock.
- Be sure to install a earth fault circuit interrupter (30 mA). Failure to do so may cause electrical shock.
- Be sure to install the required fuses or circuit breakers.

10.1 Precautions on electrical wiring work

- Fix cables so that cables do not make contact with the pipes (especially on the high pressure side).
- Secure the electrical wiring with cable ties as shown in figure so that it does not come in contact with the piping, particularly on the high-pressure side.
- Make sure no external pressure is applied to the terminal connectors.
- When installing the earth fault circuit interrupter make sure that it is compatible with the inverter (resistant to high frequency electrical noise) to avoid unnecessary opening of the earth fault circuit interrupter.

NOTE

The earth fault circuit interrupter must be a high- speed type breaker of 30 mA (< 0.1 s).

NOTE

- Maximum length of communication wirings is 50 m.
 - Power cords and communication wiring must be laid out separately, they can not be placed in the same conduit.
 - Otherwise, it may lead to electromagnetic interference. Power cords and communication wirings should not come in contact with the refrigerant pipe so as to prevent the high temperature pipe from damaging the wires.
 - Communication wirings must use shielded lines. Including indoor unit to outdoor unit PQE line ,indoor unit to controller ABXYE line.
- This unit is equipped with an inverter. Installing a phase advancing capacitor not only will reduce the power factor improvement effect, but also may cause abnormal heating of the capacitor due to high-frequency waves. Never install a phase advancing capacitor as it could lead to an accident.
 - Equipment must be earthed.
 - All high-voltage external load, if it is metal or a earthed port, must be earthed.
 - All external load current is needed less than 0.2 A, if the single load current is greater than 0.2 A, the load must be controlled through AC contactor.

10.1.1 Wiring overview

The illustration below gives an overview of the required field wiring between several parts of the installation. Refer also to "9.6 Typical application".

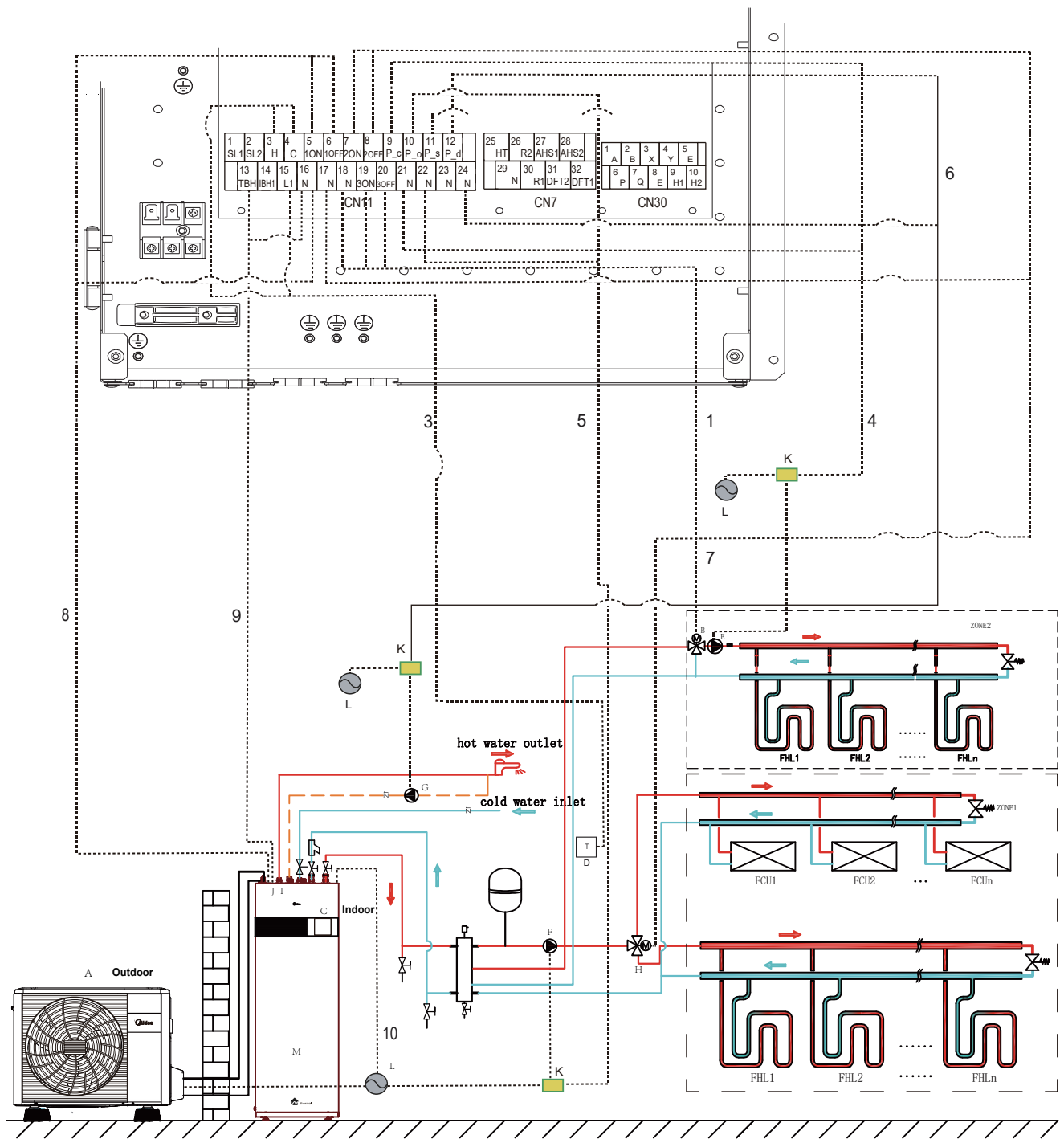

One zone for floor heating loops and fan coil

Code	Assembly unit	Code	Assembly unit
A	Outdoor unit	H	SV2: 3-way valve (field supply)
B	SV3: 3-way valve (field supply)	I	SV1: 3-way valve for domestic hot water tank (field supply)
C	User interface	J	Booster heater
D	High voltage room thermostat (field supply)	K	Contacteur
E	P_c: Zone 2 pump (field supply)	L	Power supply
F	P_o: Outside circulation pump (field supply)	M	Indoor unit
G	P_d: DHW pump (field supply)		

Item	Description	AC/DC	Required number of conductors	Maximum running current
1	SV3: 3-way valve control cable	AC	3	200 mA(a)
2	User interface cable	AC	5	200 mA
3	Room thermostat cable	AC	2	200 mA(a)
4	Zone 2 pump control cable	AC	2	200 mA(a)
5	Outside circulation pump control cable	AC	2	200 mA(a)
6	DHW pump control cable	AC	2	200 mA(a)
7	SV2: 3-way valve control cable	AC	3	200 mA(a)
8	SV1: 3-way valve control cable	AC	3	200 mA(a)
9	Booster heater control cable	AC	2	200 mA(a)
10	Power supply cable for indoor unit	AC	60	0.4 A
			100	0.4 A
			2 + GND 160	0.4 A
			60 (3 kW heater)	13.5 A
			100(3 kW heater)	13.5 A
			160(3 kW heater)	13.5 A
			4 + GND 60 (9 kW heater)	13.3 A
			100(9 kW heater)	13.3 A
			160(9 kW heater)	13.3 A

(a) Minimum cable section AWG18 (0.75 mm²).

(b)The thermistor cable are delivered with the unit: if the current of the load is large, an AC contactor is needed.

NOTE

Please use H07RN-F for the power wire, all the cables are connect to high voltage except for thermistor cable and cable for user interface.

- Equipment must be earthed.
- All high-voltage external load, if it is metal or a grounded port, must be earthed.
- All external load current is needed less than 0.2 A, if the single load current is greater than 0.2 A, the load must be controlled through AC contactor.
"AHS1" "AHS2", "A1" "A2", "R1" "R2" and "DFT1" "DFT2" wiring terminal ports provide only the switch signal.
- Please refer to image of 10.6 to get the ports position in the unit.
- Plate heat exchanger E-Heating tape and Flow switch E-Heating tape share a control port.

Field wiring guidelines

- Most field wiring on the unit is to be made on the terminal block inside the switch box. To gain access to the terminal block, remove the switch box service panel.

WARNING

Switch off all power including the unit power supply and backup heater and domestic hot water tank power supply (if applicable) before removing the switch box service panel.

- Fix all cables using cable ties.
- A dedicated power circuit is required for the backup heater.
- Installations equipped with a domestic hot water tank (field supply) require a dedicated power circuit for the booster heater. Please refer to the domestic hot water tank Installation & Owner's Manual.
- Lay out the electrical wiring so that the front cover does not rise up when doing wiring work and attach the front cover securely.
- Follow the electric wiring diagram for electrical wiring works (the electric wiring diagrams are located on the rear side of door 2).
- Install the wires and fix the cover firmly so that the cover may be fit in properly.

10.2 Precautions on wiring of power supply

- Use a round crimp-style terminal for connection to the power supply terminal board. In case it cannot be used due to unavoidable reasons, be sure to observe the following instructions.
 - Do not connect different gauge wires to the same power supply terminal. (Loose connections may cause overheating.)
 - When connecting wires of the same gauge, connect them according to the figure below.

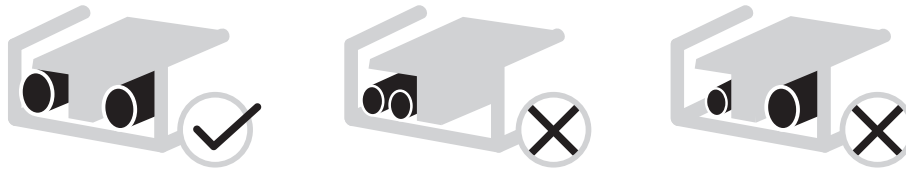

Fig. 10-1

- Use the correct screwdriver to tighten the terminal screws. Small screwdrivers can damage the screw head and prevent appropriate tightening.
- Over-tightening the terminal screws can damage the screws.
- Attach a earth fault circuit interrupter and fuse to the power supply line.
- In wiring, make certain that prescribed wires are used, carry out complete connections, and fix the wires so that outside force cannot affect the terminals.

10.3 Safety device requirements

1. Select the wire diameters(minimum value) individually for each unit based on the table below.
2. Select circuit breaker that having a contact separation in all poles not less than 3 mm providing full disconnection , where MFA is used to select the current circuit breakers and residual current operation breakers:

System		Hz	Power Current			IWPM	
			Voltage (V)	MCA (A)	MFA (A)	kW*	FLA (A)
Standard	100/190(3 kW heater)	50	220-240 / 1N	16.9	20	0.087	0.66
	100/240(3 kW heater)	50	220-240 / 1N	16.9	20	0.087	0.66
	160/240(3 kW heater)	50	220-240 / 1N	16.9	20	0.087	0.66
Optional	100/190(6 kW heater)	50	220-240 / 1N	33.1	40	0.087	0.66
	100/240(6 kW heater)	50	220-240 / 1N	33.1	40	0.087	0.66
	160/240(6 kW heater)	50	220-240 / 1N	33.1	40	0.087	0.66
	100/190(9 kW heater)	50	380-415 / 3N	16.9	20	0.087	0.66
	100/240(9 kW heater)	50	380-415 / 3N	16.9	20	0.087	0.66
	160/240(9 kW heater)	50	380-415 / 3N	16.9	20	0.087	0.66

NOTE

MCA : Min. Circuit Amps. (A)
MFA : Max. Fuse Amps. (A)
IWPM: Indoor Water Pump Motor
FLA : Full Load Amps. (A)
* : Rated Motor Output

10.4 Before connecting the wiring

- 1.Remove the bolt in the lower left corner of indoor unit.
- 2.Open the front panel.
- 3.Remove the cover of the control box.

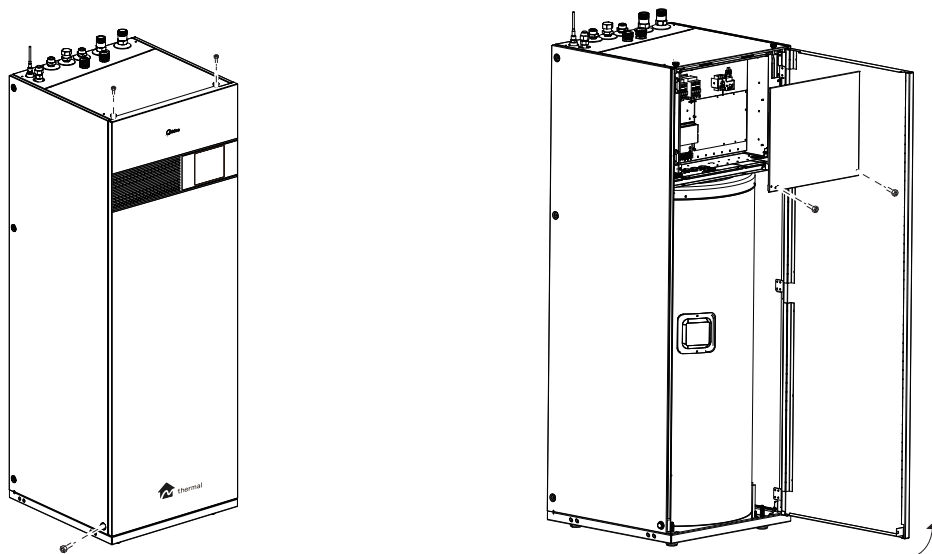

Fig. 10-2

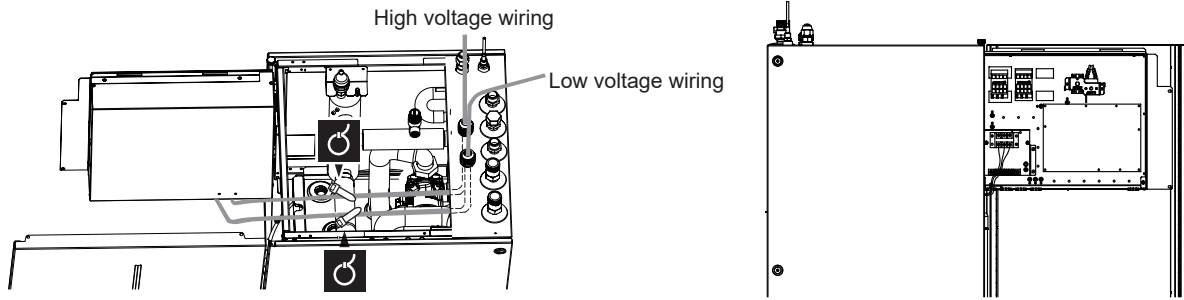
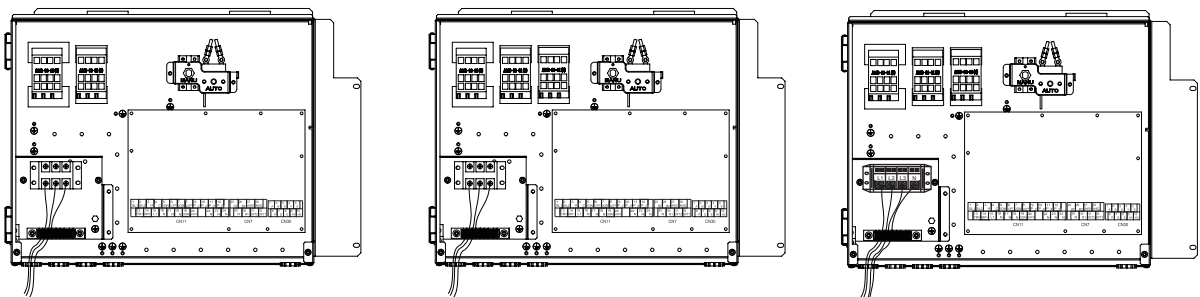
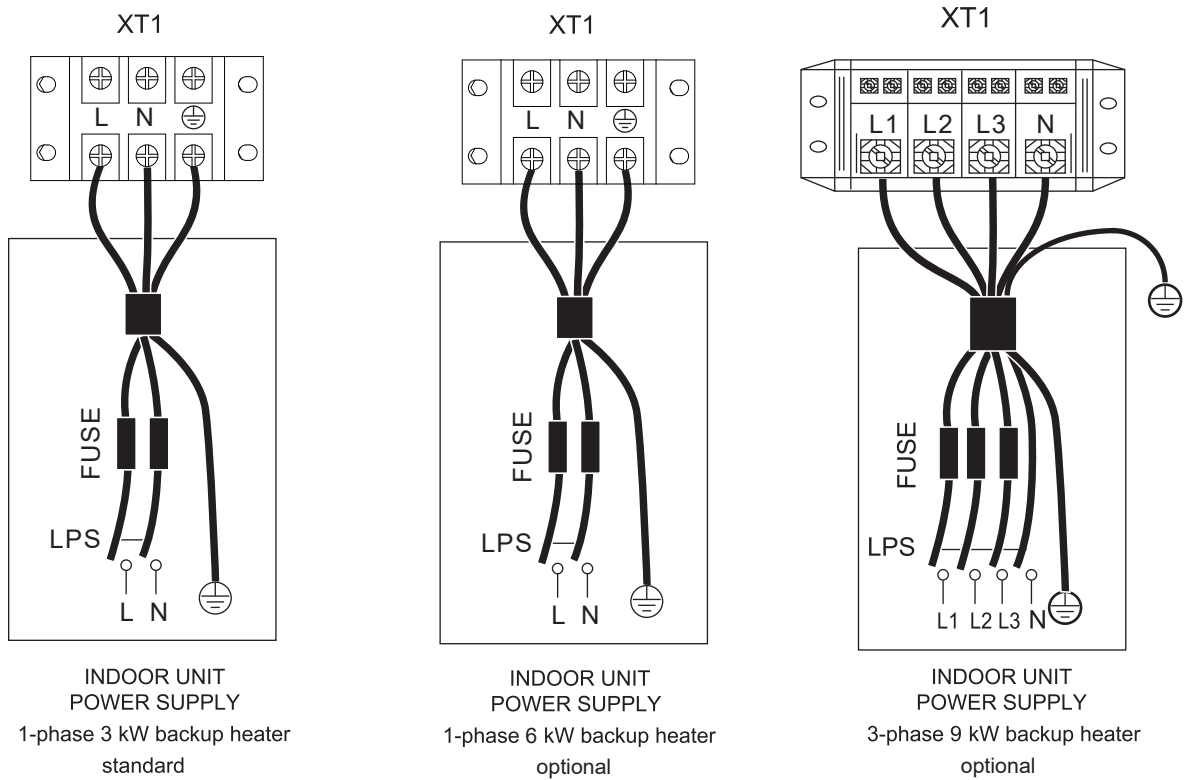

Fig.10-3

10.5 Connecting the main power supply

NOTE

Leakage Protection Switch must be installed to the Power Supply of the unit.



Unit	3 kW-1 Ph	6 kW-1 Ph	9 kW-3 Ph
Wiring size(mm ²)	4.0	8.0	4.0

- Stated values are maximum values (see electrical data for exact values).

NOTE

The earth fault circuit interrupter must be a high-speed type breaker of 30 mA (< 0.1 s). Flexible cord must meet 60245IEC(H05VV-F) standards.

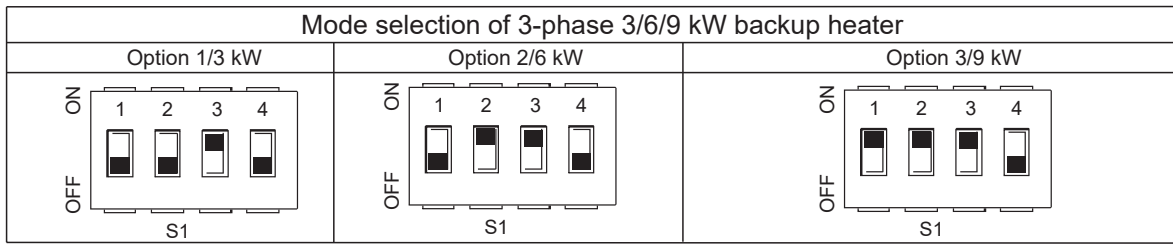

NOTE

The default of backup heater is as option 3 (for 9 kW backup heater). If 3 kW or 6 kW backup heater is needed, please ask professional installer to change the Dip switch S1 to option 1(for 3 kW backup heater) or option 2(for 6 kW backup heater), refer to 11.1.1 FUNCTION SETTING.

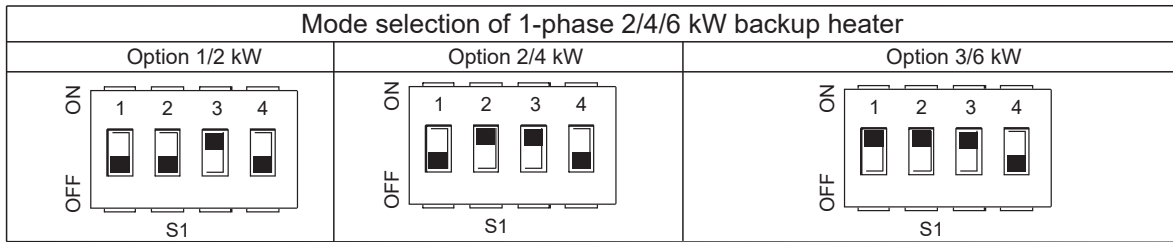

NOTE

The default of backup heater is as option 3 (for 6 kW backup heater). If 2 kW or 4 kW backup heater is needed, please ask professional installer to change the Dip switch S1 to option 1(for 2 kW backup heater) or option 2(for 4 kW backup heater), refer to 11.1.1 FUNCTION SETTING.

10.6 Connecting for other components

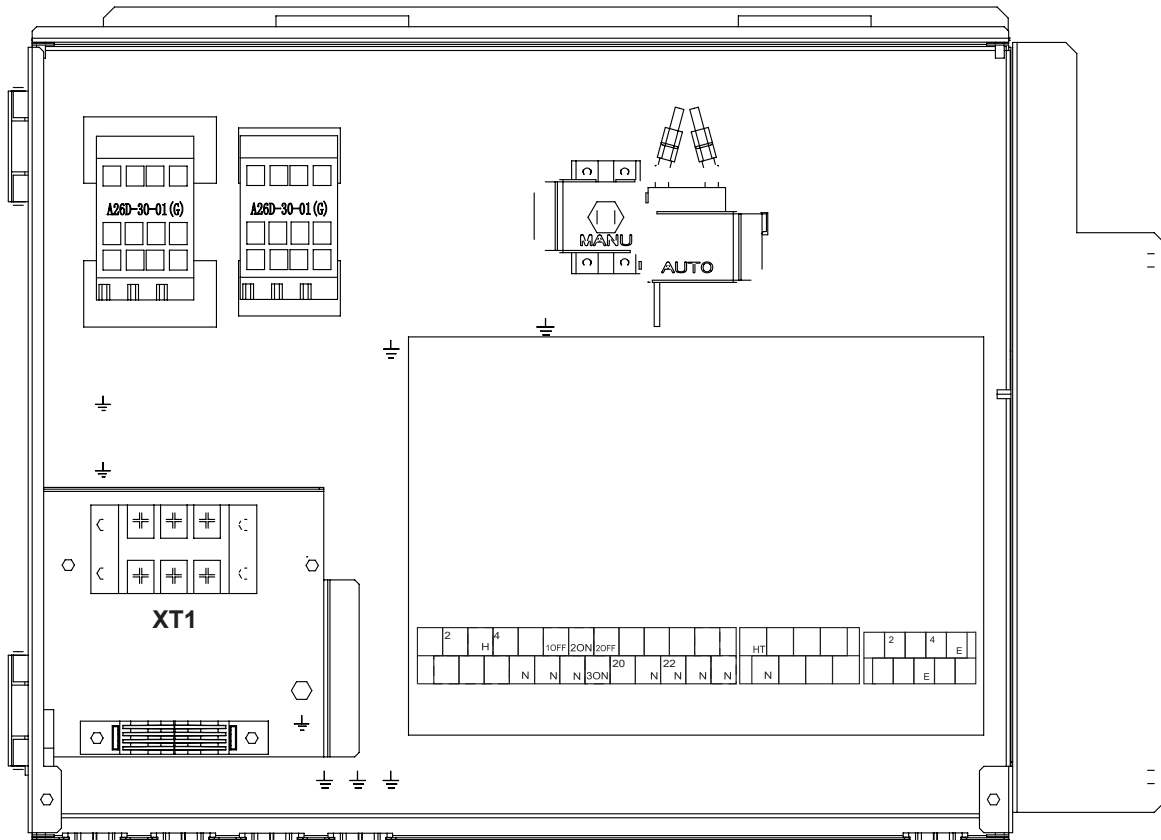

	Print		Connect to
	CN11	1	SL1
2		SL2	
3		H	Room thermostat input (high voltage)
4		C	
15		L1	
5		1ON	SV1(3-way valve) (connected in factory)
6		1OFF	
16		N	
7		2ON	SV2(3-way valve)
8		2OFF	
17		N	
9		P_c	Pumpc(zone2 pump)
21		N	
10		P_o	Outside circulation pump /zone1 pump
22		N	
11		P_s	Reserved
23		N	
12		P_d	DHW pipe pump
24		N	
13		TBH	Unavailable
16	N		
14	IBH1	Internal backup heater 1	
17	N		
18	N	SV3(3-way valve)	
19	3ON		
20	3OFF		

	Print		Connect to
	CN7	26	R2
30		R1	
31		DFT2	Indicator light for defrost or alarm status(field supply)
32		DFT1	
25		HT	Antifreeze E-heating tape(field supply)
29		N	
27		AHS1	Unavailable
28		AHS2	

	Print		Connect to
	CN30	1	A
2		B	
3		X	
4		Y	
5		E	
6		P	Outdoor unit
7		Q	
8		E	
9		H1	Internal cascaded machine
10		H2	

Port provide the control signal to the load.Two kind of control signal port:

Type 1 : Dry connector without voltage.

Type 2 : Port provide the signal with 220 V voltage. If the current of load is < 0.2 A, load can connect to the port directly. If the current of load is >= 0.2 A, the AC contactor is required to connected for the load.

10.6.1 connecting the communication wiring to outdoor unit

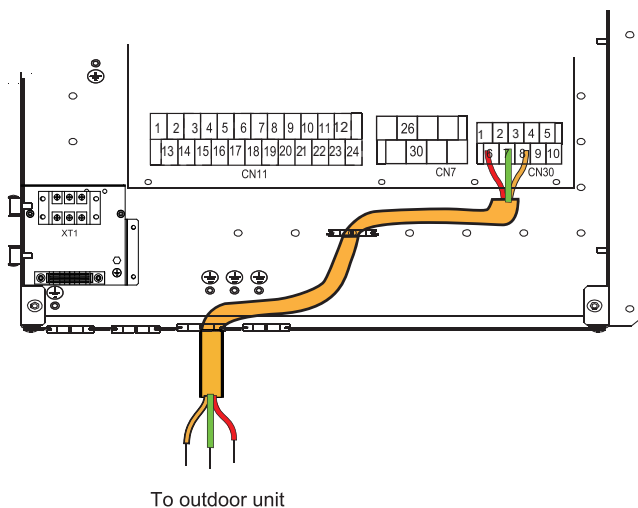

10.6.2 For remote shut down:

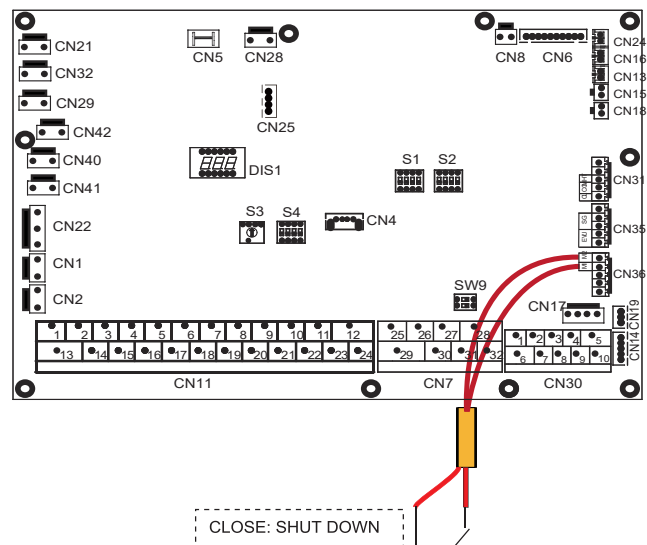

10.6.3 Room thermostat (Low voltage):

There are three methods for connecting the thermostat cable (as described in the pictures) and it depends on the application.

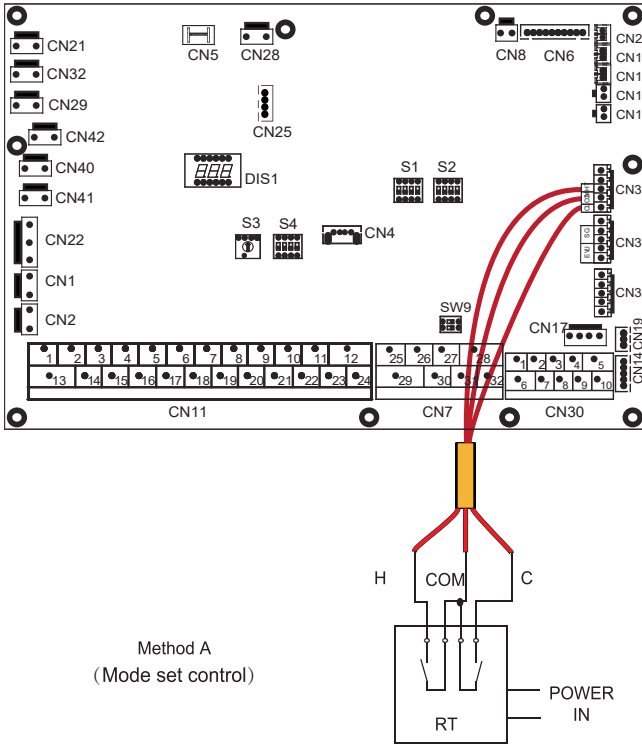

RT=Room Thermostat

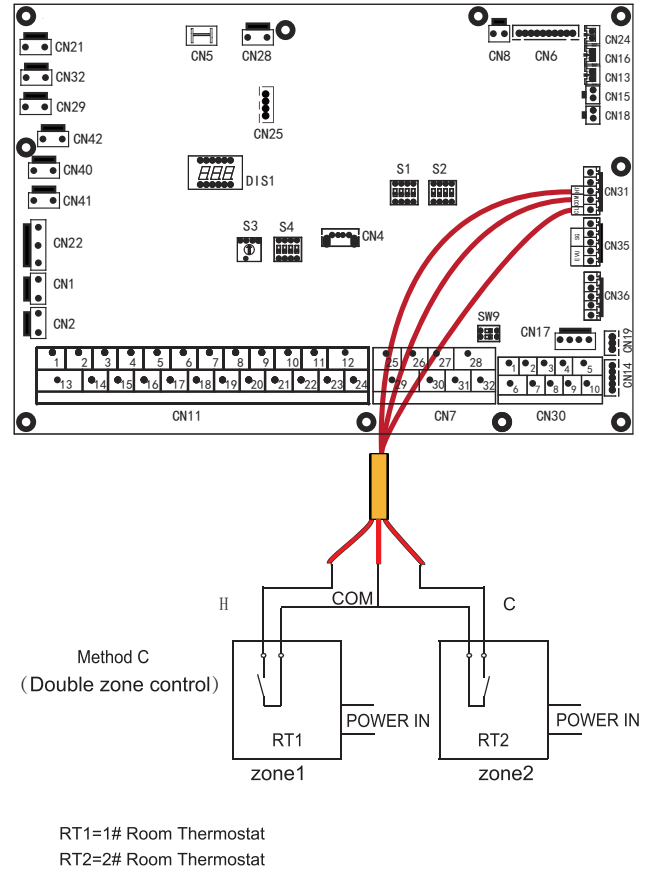
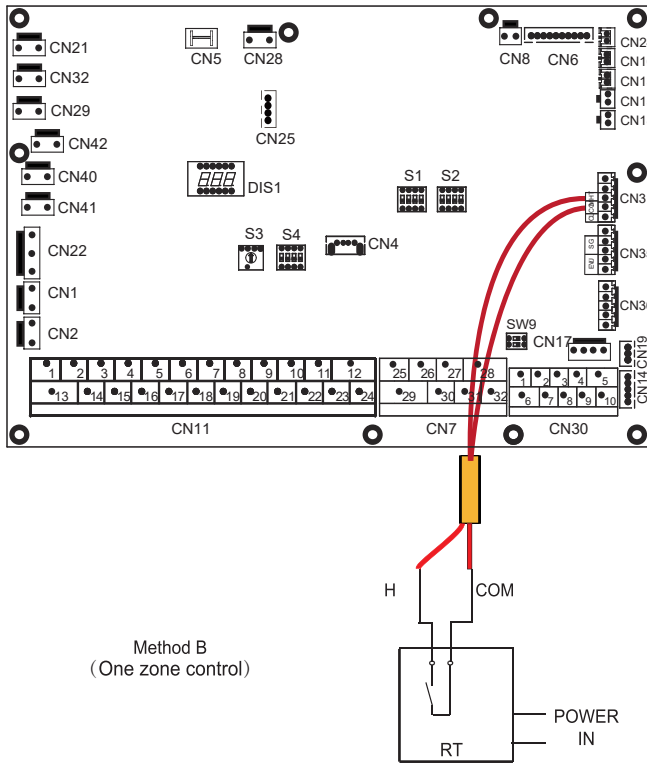

NOTE

The unit only sends an ON/OFF signal to the heater.

• Method A (Mode set control)

RT can control heating and cooling individually, like the controller for 4-pipe FCU. When the indoor unit is connected with the external temperature controller, user interface FOR SERVICEMAN set ROOM THERMOSTAT to MODE SET:

- A.1 When unit detect voltage is 12 VDC between CL and COM ,the unit operates in the cooling mode.
- A.2 When unit detect voltage is 12 VDC between HT and COM, the unit operates in the heating mode.
- A.3 When unit detect voltage is 0 VDC for both side(CL-COM, HT-COM) the unit stop working for space heating or cooling.
- A.4 When unit detect voltage is 12 VDC for both side(CL-COM, HT-COM) the unit working in cooling mode.

• Method B (One zone control)

RT provide the switch signal to unit. User interface FOR SERVICEMAN set ROOM THERMOSTAT to ONE ZONE:

- B.1 When unit detect voltage is 12VDC between HT and COM, unit turns on.
- B.2 When unit detect voltage is 0VDC between HT and COM, unit turns off.

• Method C (Double zone control)

Indoor unit is connected with two room thermostat, while user interface FOR SERVICEMAN set ROOM THERMOSTAT to DOUBLE ZONE:

- C.1 When unit detect voltage is 12 VDC between HT and COM , zone1 turn on. When unit detect voltage is 0 VDC between HT and COM, zone1 turn off.
- C.2 When unit detect voltage is 12 VDC between CL and COM, zone 2 turn on according to climate temp curve. When unit detect voltage is 0 V between CL and COM, zone2 turn off.
- C.3 When HT-COM and CL-COM are detected as 0 VDC, unit turn off.
- C.4 when HT-COM and CL-COM are detected as 12 VDC, both zone1 and zone 2 turn on.

The wiring of the thermostat should correspond to the settings of the user interface.Refer to **ROOM THERMOSTAT**. Power supply of machine and room thermostat must be connected to the same Neutral Line . When ROOM THERMOSTAT is not set to NON. the indoor temperature sensor Ta can't be set to valid Zone 2 can only operate in heating mode, When cooling mode is set on user interface and zone 1 is OFF, "CL" in zone 2 closes, system still keeps 'OFF'. While installation, the wiring of thermostats for zone1 and zone 2 must be correct.

a) Procedure

Connect the cable to the appropriate terminals as shown in the picture. Fix the cable with cable ties to the cable tie mountings to ensure stress relief.

10.6.4 For smart grid:

The unit has smart grid function, there are two ports on PCB to connect SG signal and EVU signal as following(SG is municipal power, and EVU is free power):

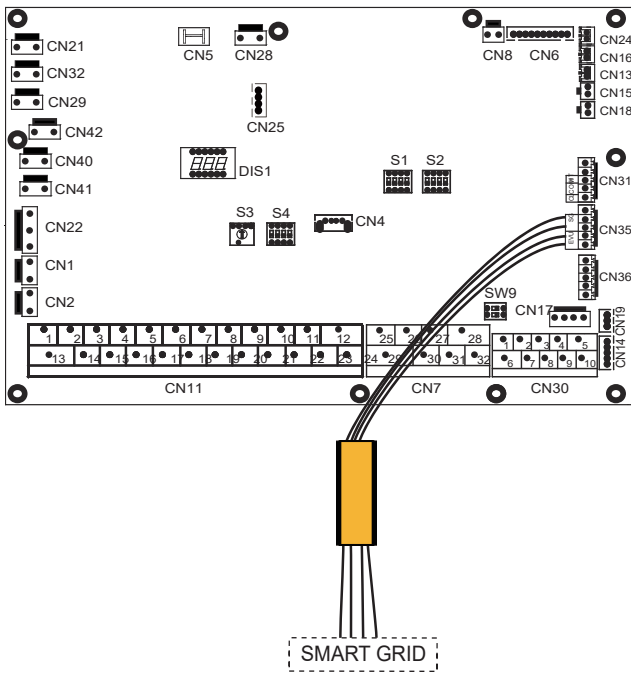

1. When EVU signal is on, and SG signal is on, as long as the DHW mode is set to be valid, the heat pump and IBH will operate in DHW mode at the same time automatically. When T5 rises to 60°C, the DHW mode will exit and switch to cooling/heating mode normally.
2. When EVU signal is on, and SG signal is off, as long as the DHW mode is set to be valid and the mode is on, the heat pump and IBH will operate in DHW mode at the same time automatically, when $T5 \geq \text{Min}(T5S+3, 60)$, the DHW mode will exit and switch to cooling/heating mode normally. (T5S is the setting temperature)
3. When EVU signal is off, and SG signal is off, the unit operates normally.
4. When EVU signal is off, and SG signal is on, the unit operates as below: The unit will not operate DHW mode, the TBH and IBH are invalid, Tank heater, Fast DHW and disinfect function are invalid.

10.6.5 For P_o:

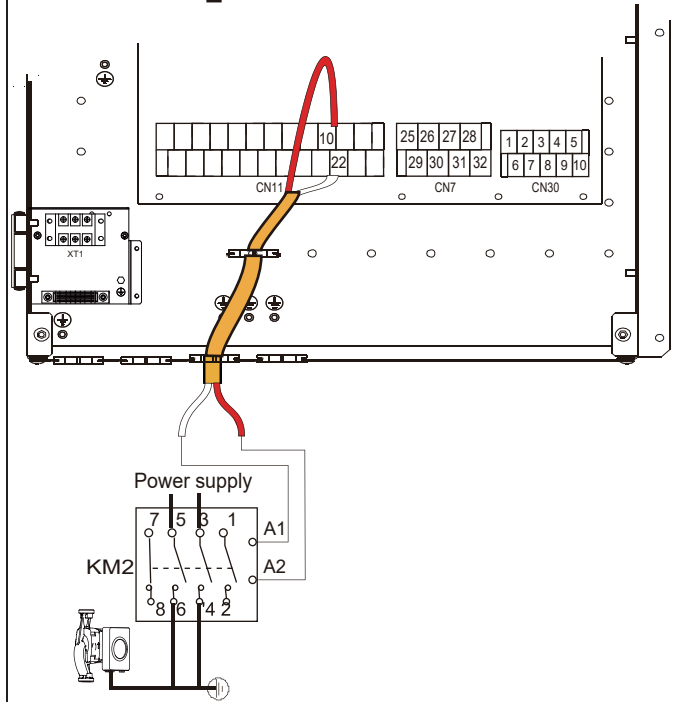

Voltage	220-240 VAC
Maximum running current(A)	0.2
Wiring size(mm ²)	0.75
Control port signal type	Type 2

a) Procedure

Connect the cable to the appropriate terminals as shown in the picture. Fix the cable with cable ties to the cable tie mountings to ensure stress relief.

10.6.6 For P_c

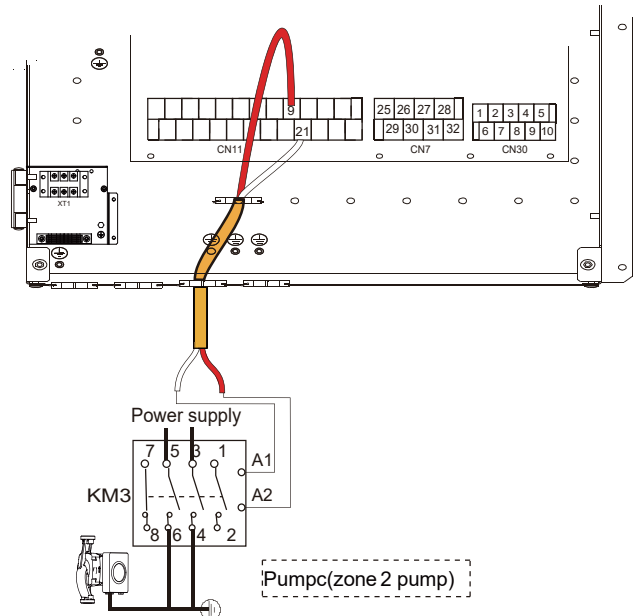

Voltage	220-240 VAC
Maximum running current(A)	0.2
Wiring size(mm ²)	0.75
Control port signal type	Type 2

10.6.7 For P_d

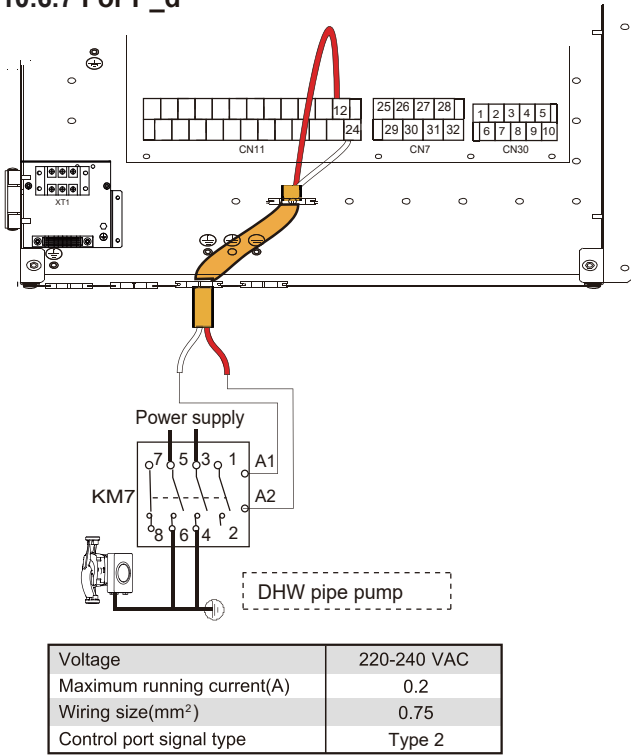

10.6.8 For 3-way valve SV2

The illustration below is for this type of SV:

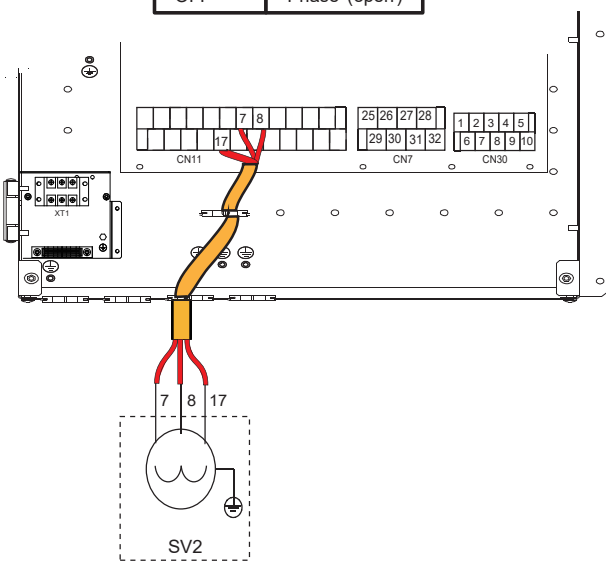
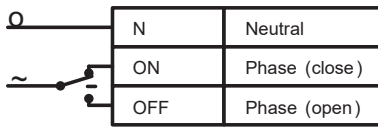

The illustration below is for this type of SV:

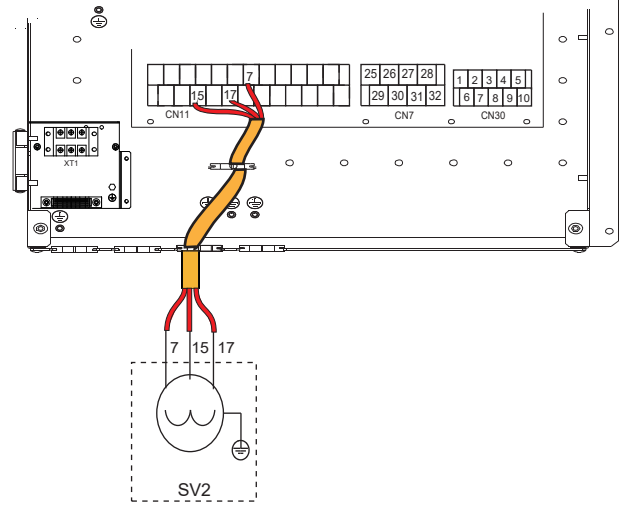
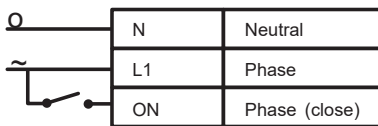

10.6.9 For 3-way valve SV3

The illustration below is for this type of SV:

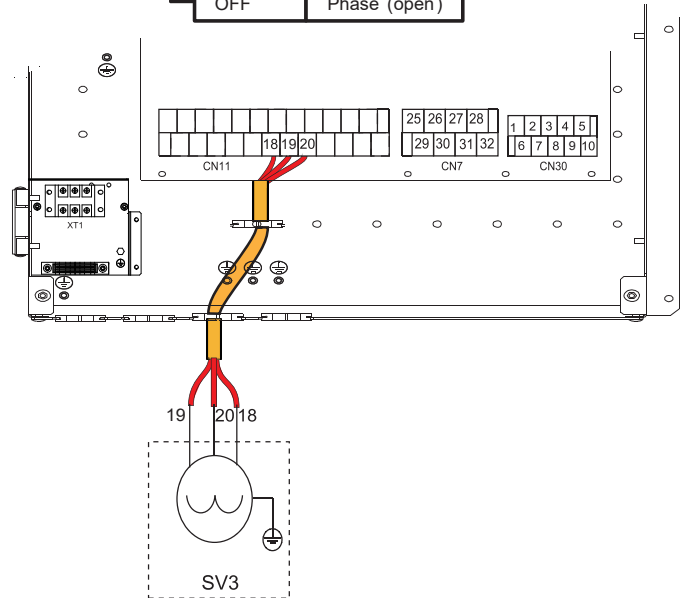
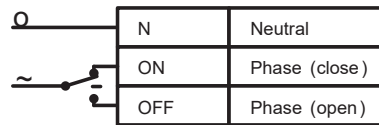

The illustration below is for this type of SV:

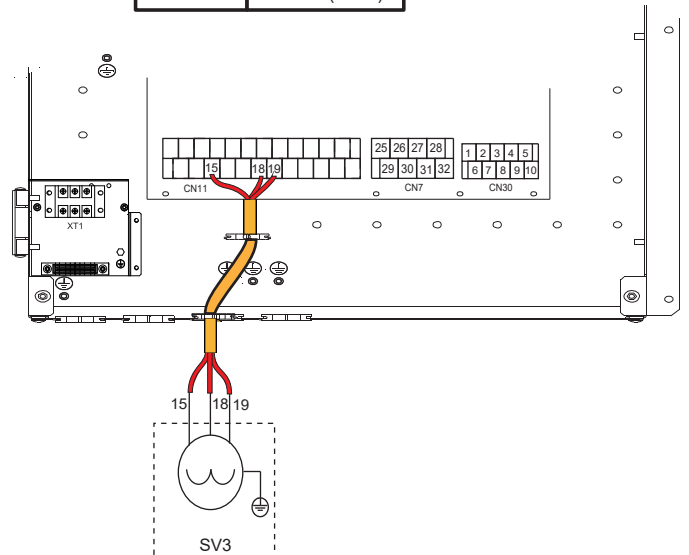
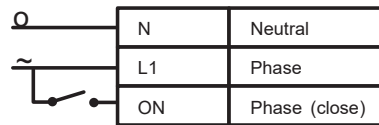

10.6.10 For defrosting signal output:

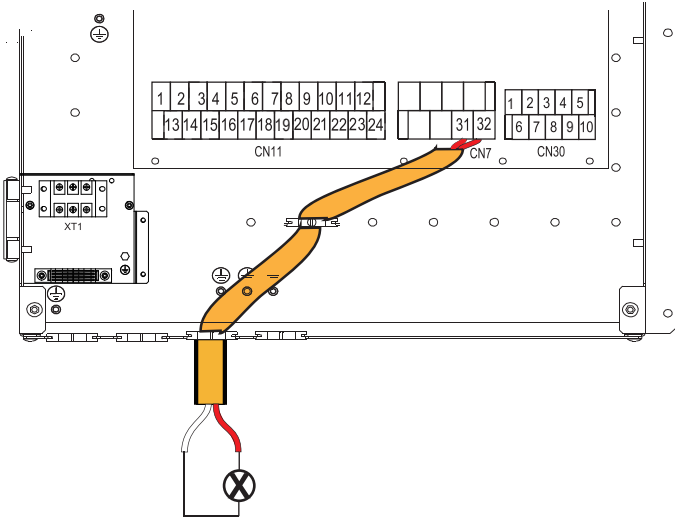

10.6.11 For unit operating status signal output

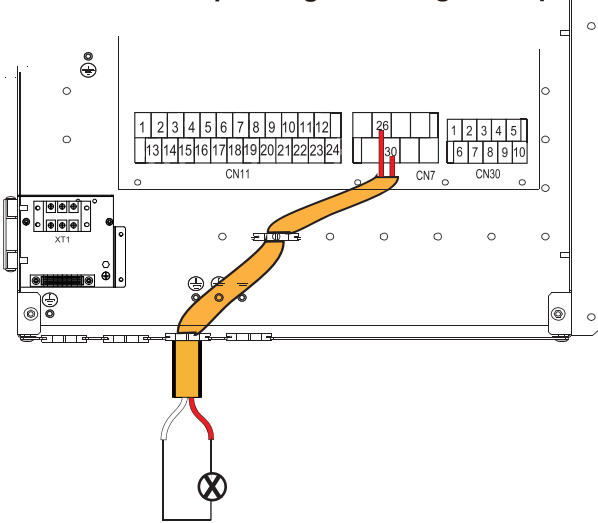

10.6.12 For room thermostat:

Room thermostat type 1(High voltage): "POWER IN" provide the working voltage to the RT, doesn't provide the voltage to the RT connector directly. Port "15 L1" provide the 220 V voltage to the RT connector. Port "15 L1" connect from the unit main power supply port L of 1- phase power supply. Room thermostat type 2(Low voltage) : "POWER IN" provide the working voltage to the RT

There are two optional connecting methods depending on the room thermostat type.

Room thermostat type 1 (High voltage):

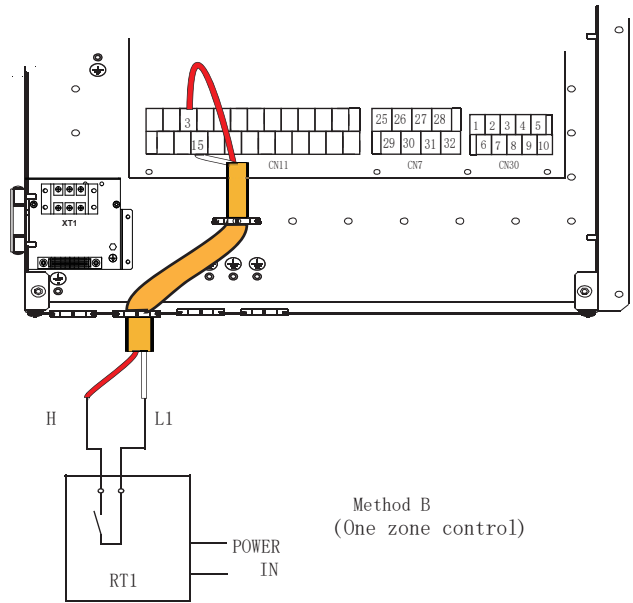
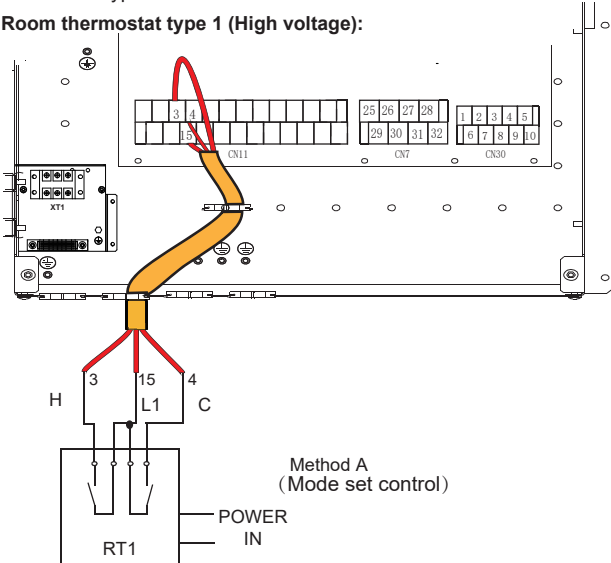

Method B
(One zone control)

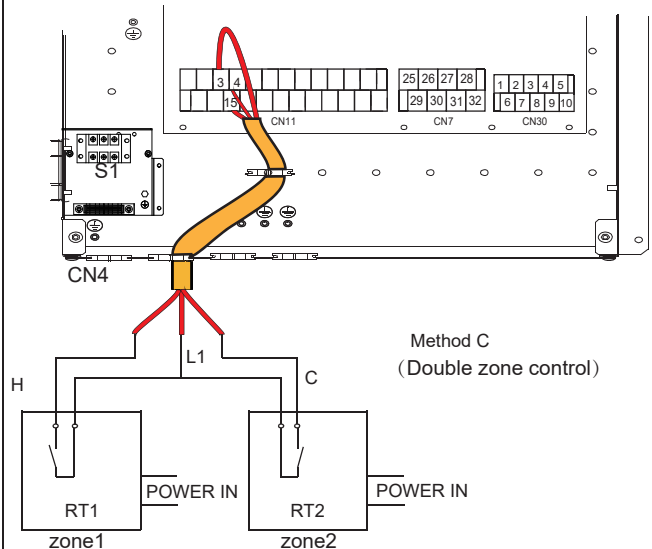

Method C
(Double zone control)

Voltage	220-240VAC
Maximum running current(A)	0.2
Wiring size(mm ²)	0.75

There are three methods for connecting the thermostat cable (as described in the picture above) and it depends on the application.

• Method A (Mode set control)

RT can control heating and cooling individually, like the controller for 4-pipe FCU. When the indoor unit is connected with the external temperature controller, user interface FOR SERVICEMAN set ROOM THERMOSTAT to MODE SET

A.1 When unit detect voltage is 230 VAC between C and L1 ,the unit operates in the cooling mode.

A.2 When unit detect voltage is 230 VAC between H and L1, the unit operates in the heating mode.

A.3 When unit detect voltage is 0 VAC for both side(C-L1, H-L1) the unit stop working for space heating or cooling.

A.4 When unit detect voltage is 230 VAC for both side(C-L1, H-L1) the unit working in cooling mode.

• Method B (One zone control)

RT provide the switch signal to unit. User interface FOR SERVICEMAN set ROOM THERMOSTAT to ONE ZONE:

B.1 When unit detect voltage is 230 V AC between H and L1, unit turns on.
 B.2 When unit detect voltage is 0 V AC between H and L1, unit turns off.

• **Method C** (Double zone control)
 Indoor unit is connected with two room thermostat, while user interface FOR SERVICEMAN set ROOM THERMOSTAT to DOUBLE ZONE:

C.1 When unit detect voltage is 230 VAC between H and L1 ,zone 1 turns on.When unit detect voltage is

0 VAC between H and L1, zone1 turns off.

C.2 When unit detect voltage is 230 VAC between C and L1, zone 2 turns on according to climate temp curve. When unit detect voltage is 0 V between C and L1, zone2 turns off.

C.3 When H-L1 and C-L1 are detected as 0 VAC, unit turns off.

C.4 when H-L1 and C-L1 are detected as 230 VAC, both zone 1 and zone 2 turn on.

11 START-UP AND CONFIGURATION

The unit should be configured by the installer to match the installation environment (outdoor climate, installed options, and user expertise.

CAUTION

It is important that all information in this chapter is read sequentially by the installer and that the system is configured applicable.

11.1 DIP switch settings overview

11.1.1 Function setting

DIP switch S1、 S2 and S4 is located on the indoor unit main control board and allows configuration of additional heating source thermistor installation, the second inner backup heater installation, etc.

WARNING

Switch off the power supply before opening the switch box service panel and making any changes to the DIP switch settings.

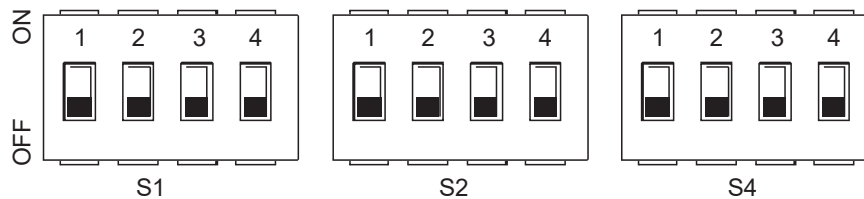

DIP switch	ON=1	OFF=0	Factory defaults	DIP switch	ON=1	OFF=0	Factory defaults	DIP switch	ON=1	OFF=0	Factory defaults	
S1	1/2	0/0=IBH(One-step control)	Refer to electrically controlled wiring diagram	S2	1	Reserved	Refer to electrically controlled wiring diagram	S4	1	Master=clear all slave address codes Slave=Clear self-address code	Keep current address code	Refer to electrically controlled wiring diagram
		0/1=IBH(Two-step control)				Reserved				Reserved		
	1/1=IBH(Three-step control)	0/0=Reserved 0/1=fixed speed pump 1/0=Reserved 1/1=variable speed pump			3	With MH-KIT			Without MH-KIT			
	3/4	0/0=Without IBH 1/0=With IBH 0/1=Reserved 1/1=Reserved		3/4				4	Imperial unit	Metric unit		

11.2 Initial start-up at low outdoor ambient temperature

During initial start-up and when water temperature is low, it is important that the water is heated gradually. Failure to result in concrete floors cracking due to rapid temperature change. Please contact the responsible cast concrete contractor for further details.

To do so, the lowest water flow set temperature can be decreased to a value between 25 °C and 35 °C by adjusting SERVICEMAN.

11.3 Pre-operation checks

Checks before initial start-up

⚠ DANGER

- Switch off the power supply before making any connections.
- After the installation of the unit, check the following before switching on the circuit breaker:
- Field wiring: Make sure that the field wiring between the local supply panel and unit and valves (when applicable), unit and room thermostat (when applicable), unit and domestic hot water tank, and unit and backup heater kit have been connected according to the instructions described in the chapter 10 "FIELD WIRING" , according to the wiring diagrams and to local laws and regulations.
- Fuses, circuit breakers, or protection devices Check that the fuses or the locally installed protection devices are of the size and type specified in 10.3 "Safety device requirements" . Make sure that no fuses or protection devices have been bypassed.
- Backup heater circuit breaker: Do not forget to turn on the backup heater circuit breaker in the switchbox (it depends on the backup heater type). Refer to the wiring diagram.
- Booster heater circuit breaker: Do not forget to turn on the booster heater circuit breaker (applies only to units with optional domestic hot water tank installed).
- Earth wiring : Make sure that the earth wires have been connected properly and that the earth terminals are tightened.
- Internal wiring: Visually check the switch box for loose connections or damaged electrical components.
Mounting: Check that the unit is properly mounted, to avoid abnormal noises and vibrations when starting up the unit.
- Damaged equipment: Check the inside of the unit for damaged components or squeezed pipes.
Refrigerant leak: Check the inside of the unit for refrigerant leakage. If there is a refrigerant leak, call your local dealer.
- Power supply voltage: Check the power supply voltage on the local supply panel. The voltage must correspond to the voltage on the identification label of the unit.
- Air purge valve: Make sure the air purge valve is open (at least 2 turns).
- Shut-off valves: Make sure that the shut-off valves are fully open.

11.4 Setting the pump

The pump is controlled via a digital low-voltage pulse-width modulation signal which means that the speed of rotation depends on the input signal. The speed changes as a function of the input profile.

The relationships between the head and the water flow rated, the PWM Return and the water flow rated are shown in the graph below.

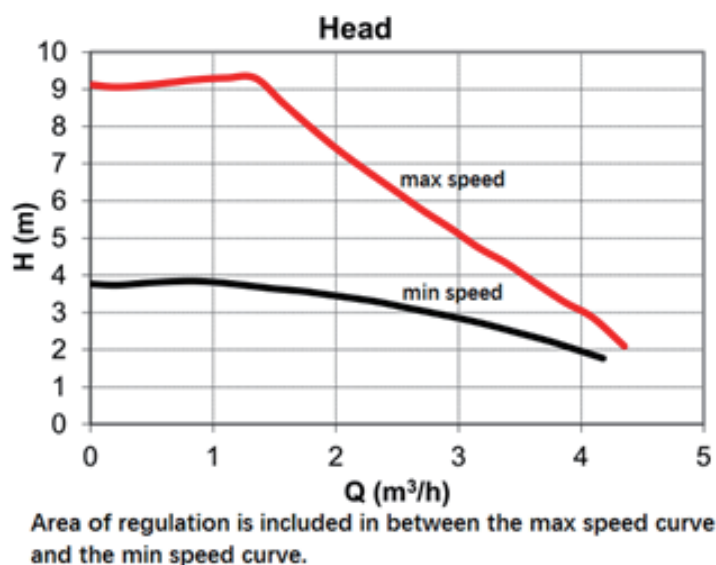

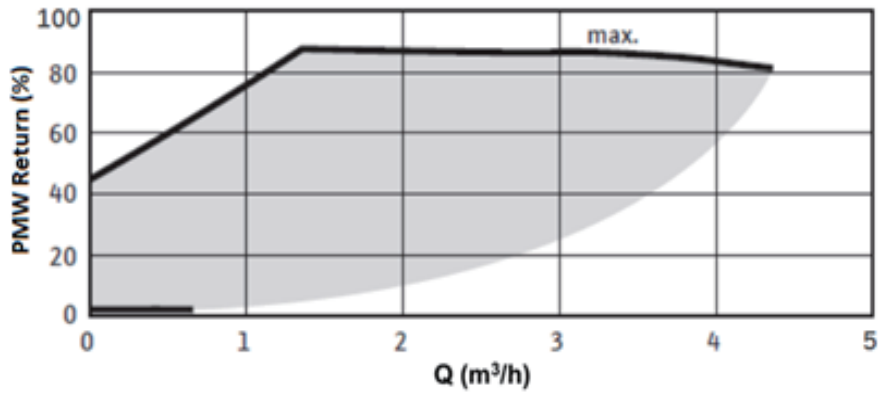

The internal pump maintains maximum output, the indoor unit can provide the head and flow:

Available external static pressure VS Flow rate

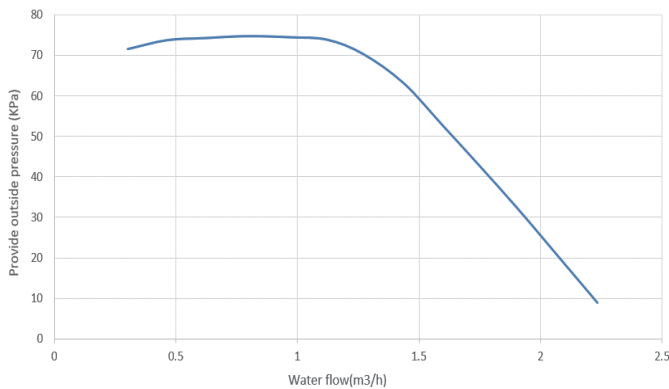

Indoor unit 190L

Available external static pressure VS Flow rate

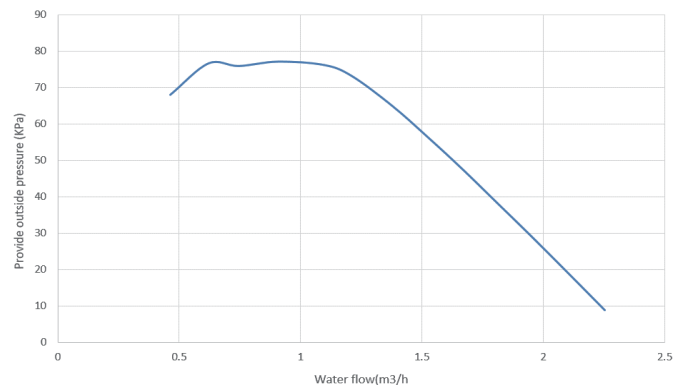

Indoor unit 240L

⚠ CAUTION

If the valves are at the incorrect position, the circulation pump will be damaged.

⚠ DANGER

If it's necessary to check the running status of the pump when unit power on, please do not touch the internal electronic control box components to avoid electric shock.

Failure diagnosis at first installation

- If nothing is displayed on the user interface, it is necessary to check for any of the following abnormalities before diagnosing possible error codes.
 - Disconnection or wiring error (between power supply and unit and between unit and user interface).
 - The fuse on the PCB may be broken.
- If the user interface shows "E8" or "E0" as an error code, there is a possibility that there is air in the system, or the water pressure in the system is less than the required minimum.

More error code and failure causes can be found in 16 "ERROR CODES".

11.5 Field settings

The unit should be configured to match the installation environment (outdoor climate, installed options, etc.) and user demand. A number of field settings are available. These settings are accessible and programmable through "FOR SERVICEMAN" in user interface.

Procedure



To change one or more field settings, proceed as follows.

NOTE

Temperature values displayed on the wired controller (user interface) are in °C.

To initialize the unit, a group of advanced settings should be provided by the installer. The advanced settings are accessible in FOR SERVICEMAN mode.

How to enter FOR SERVICEMAN mode

Press and hold  and  simultaneously for 3 seconds to enter the authorization page. Enter password 234 and confirm it. Then, the system jumps into the page with a list of advanced settings.

For serviceman

0 0 0

Please input the password

For serviceman

DHW setting	>
Cooling setting	>
Heating setting	>
Auto mode setting	>

NOTE

"FOR SERVICEMAN" is only for installer or other specialist with sufficient knowledge and skills.

The end user who use "FOR SERVICEMAN" is regarded as improper use.

Save the settings and quit FOR SERVICEMAN mode

After all settings are adjusted, press , and the confirmation page pops out. Select Yes and confirm to quit FOR SERVICEMAN mode.

NOTE

- The settings are saved automatically after you quit FOR SERVICEMAN mode.
- Temperature values displayed on the wired controller are measured in °C.

11.5.1 DHW setting

Select the target item and enter the setting page. Adjust the launch settings and values based on end user demands.

DHW setting

DHW mode	YES
Disinfect	NO
DHW priority	YES
Pump_D	YES

All set parameters and limitations can be found in 11.3 Set Operating Parameters.

11.5.2 Cooling setting

Cooling setting	
Cool mode	YES
t_T4_FRESH_C	0.5 hours
T4CMAX	52°C
T4CMIN	10°C

Refer to 11.5.1 DHW setting for the operation method.

11.5.3 Heating setting

Heating setting	
Heating mode	YES
t_T4_FRESH_H	0.5hours
T4HMAX	25°C
T4HMIN	-15°C

Refer to 11.5.1 DHW setting for the operation method. Either cooling mode or heating mode must be enabled, and they cannot be both set to NO at the same time.

11.5.4 Auto mode setting

Auto mode setting	
T4AUTOCMIN	25°C
T4AUTOHMAX	17°C

Refer to 11.5.1 DHW setting for the operation method.

11.5.5 Temp. type setting

Temp. type setting	
Water flow temp.	YES
Room temp.	NO
Double zone	YES

Refer to 11.5.1 DHW setting for the operation method. When both DOUBLE ZONE and ROOM TEMP. are enabled, the room temperature control is valid only for Zone 2, and Zone 1 is always under water temperature control.

When Room temp. is enabled, the temperature curve for the room temperature control zone is enforced, and the set temperature of the room temperature control zone can still be adjusted. The type of the temperature curve and the temperature offset can be set. (The unit will stop running if either the set temperature or the temperature curver is reached).

11.5.6 Room thermostat setting

Room thermostat setting	
Room thermostat	YES

Refer to 11.5.1 DHW setting for the operation method.

- When Room thermostat is set to any value rather than NO, the setting of Temp. type is invalid.
- When Room thermostat is set to DOUBLE ZONE, DOUBLE ZONE is enabled automatically, and the temperature control mode is water temperature control.
- When Room thermostat is set to MODE SETTING/ONE ZONE, DOUBLE ZONE is disabled automatically, and the temperature control mode is water temperature control.

1) When Room thermostat is set to NO, the room thermostat is invalid.

2) When Room thermostat is set to MODE SETTING, 10.5.6.2 Mode setting priority is visible. The wired controller cannot be used to turn on/off the unit or set the operation mode. Besides the timer related to DHW, all timers in Schedule are invalid. The unit can read the operating status of the unit, and set the temperature if the temperature curve is inactive.

3) When Room thermostat is set to ONE ZONE, the wired controller cannot be used to turn on/off Zone 1. Besides the timer related to DHW, all timers in Schedule are invalid. The unit can read the operating status of the unit, and set the operation mode (excluding Auto mode), and the temperature if the temperature curve is inactive.

4) When Room thermostat is set to DOUBLE ZONE, the wired controller cannot be used to turn on/off the Zone 1 or Zone 2. Besides the timer related to DHW, all timers in Schedule are invalid. The unit can read the operating status of the unit, and set the operation mode (excluding Auto mode), and the temperature if the temperature curve is inactive.

11.5.7 Other heat source

Other heat source	
IBH function	YES
dT1_IBH_ON	5°C
t_IBH_DELAY	15minutes
T4_IBH_ON	-15°C

Refer to 11.5.1 DHW setting for the operation method.

- 1) When EnSwitchPDC is set to NO, T4_AHS_ON can be set manually. When EnSwitchPDC is set to YES, T4_AHS_ON cannot be set manually.
- 2) When AHS function is set to NO, EnSwitchPDC is enforced to be NO.
- 3) When DHW mode is invalid, IBH function is enforced to be Heating.
- 4) When AHS function is set to NO, AHS_PUMPI CONTROL is enforced to be RUN.

11.5.8 Service call

Service call

Phone number 0000000000000000

Mobile number 0000000000000000

Up to two phone numbers can be saved, and the maximum length of the phone numbers is 15 characters. If the length is smaller than 15 character, use 0 in the front to indicate blank characters.

11.5.9 Restoration of factory settings

All the settings will come back to factory default. Do you want to restore factory settings?

NO | YES

Allow all operating parameters to be restored to the factory preset values.

Select YES and confirm to validate this function.

11.5.10 Trail run

Refer to 12. Commissioning for further information.

11.5.11 Special function

Special function

Preheating for floor >

Floor drying up >

Preheating for floor

Provide mild heat to the underfloor water piping for initial heating operation to diminish the risk of damage to the floor and piping system.

Preheating for floor

Preheating for floor

T1S 25°C

t_ARSTH 72hours

Elapsed time --

Preheating for floor

Tw_out temp. 0°C

The first line is the operating status. Grey means it is off, and green means it is on.

T1S is the set temperature. t_ARSTH is the duration. Elapsed time is the time for which the function is enabled. Tw_out temp. is the current leaving water temperature.

Floor drying up

Provide mild heat to the concrete or other structural materials around the underfloor water piping in a certain period of time, accelerate the process of dehumidification.

Floor drying up

Floor drying up

t_Dryup 8days

t_Highpeak 5days

t_Drydown 5days

Floor drying up

t_Drypeak 45°C

Start time 00:00

Start date 12-02-2023

The first line is the status indicator. Grey means it is off, and green means it is on.

t_Dryup is the time for which the unit rises the temperature. t_Highpeak is the time for which the unit maintains the temperature. t_Drydown is the time for which the unit drops the temperature. t_Drypeak is the target temperature. This function will be enabled only when the time reaches the Start time and Start day.

When the function is enabled, you can see the interface as below.

Floor drying up

Floor drying up is on.
Tw_out 15°C
The floor drying up is running for 3 days.

11.5.12 Auto restart

Auto restart

Auto restart cooling/heating mode	YES
Auto restart DHW mode	NO

Refer to 11.5.1 DHW setting for the operation method.

11.5.13 Power input limitation

Power input limitation

Power input limitation	1
------------------------	---

Refer to 11.5.1 DHW setting for the operation method.

11.5.14 Input definition

Input definition

M1 M2	Remote ON/OFF
Smart grid	NO
Tbt	NO
P_X port	Defrost

Refer to 11.5.1 DHW setting for the operation method.

11.5.15 Cascade setting

Cascade setting

PER_START	10%
TIME_ADJUST	5minutes

Refer to 11.5.1 DHW setting for the operation method.

11.5.16 HMI address setting

HMI address setting

HMI address for BMS	1
Stop BIT	1

Refer to 11.5.1 DHW setting for the operation method.

11.5.17 Common setting

Common setting

t_DELAY PUMP	2.0minutes
t_ANTILOCK PUMP	24hours
t2_ANTILOCK PUMP RUN	60seconds
t1-ANTILOCK SV	24hours

Refer to 11.5.1 DHW setting for the operation method.

11.5.18 Clear energy data

Clear all energy metering data.

All energy data will be cleaned.
Do you want to clear energy data?

NO	YES
----	-----

Refer to 11.5.1 DHW setting for the operation method.

11.6 Operation settings

Title	Code	State	Default	Minimum	Maximum	Set interval	Unit
DHW heating setting	DHW mode	Enable or disable DHW mode: 0=NO, 1=YES	1	0	1	1	/
	Disinfect	Enable or disable the disinfect mode: 0=NO, 1=YES	1	0	1	1	/
	DHW priority	Enable or disable DHW priority mode: 0=NO, 1=YES	1	0	1	1	/
	Pump_D	Enable or disable DHW pump mode: 0=NO, 1=YES	0	0	1	1	/
	DHW priority time set	Enable or disable DHW priority time setting: 0=NO, 1=YES	0	0	1	1	/
	dT5_ON	The temperature difference for starting DHW mode	10	1	30	1	°C
	dT1S5	The difference value between Twout and T5 in DHW mode	10	5	40	1	°C
	T4DHWMAX	The maximum ambient temperature at which the heat pump can operate for domestic water heating	46	35	46	1	°C
	T4DHWMIN	The minimum ambient temperature at which the heat pump can operate for domestic water heating	-10	-25	30	1	°C
	T5S_Disinfect	The target temperature of water in the domestic hot water tank in DISINFECT mode	65	60	70	1	°C
	t_DI_HIGHTEMP.	The time for which the highest temperature of water in the domestic hot water tank in DISINFECT mode lasts	15	5	60	5	Minutes
	t_DI_MAX	The maximum time for which disinfection lasts	210	90	300	5	Minutes
	t_DHWHP_Restrict	The operating time for heating/cooling	30	10	600	5	Minutes
	t_DHWHP_MAX	The maximum continuous operating time of the heat pump in DHW PRIORITY mode	90	10	600	5	Minutes
	Pump_D timer	Enable or disable the DHW pump to run as scheduled and to keep running for PUMP RUNNING TIME: 0=NO, 1=YES	1	0	1	1	/
Pump_D running time	The certain time for which the DHW pump keeps running	5	5	120	1	Minutes	
Pump_D disinfect	Enable or disable the DHW pump to operate when the unit is in DISINFECT mode and T5 is larger than or equal to T5S_DI-2: 0=NO, 1=YES	1	0	1	1	/	
Cooling setting	Cooling mode	Enable or disable the cooling mode:0=NO,1=YES	1	0	1	1	/
	t_T4_Fresh_C	The refresh time of climate-related curves in cooling mode	0.5	0.5	6	0.5	Hours
	T4CMAX	The highest ambient operating temperature in cooling mode	52	35	52	1	°C
	T4CMIN	The lowest ambient operating temperature in cooling mode	10	-5	25	1	°C
	dT1SC	The temperature difference for starting the heat pump (T1)	5	2	10	1	°C
	dTSC	The temperature difference for starting the heat pump (Ta)	2	1	10	1	°C
	Zone 1 C-emission	The type of Zone 1 terminal for cooling mode:0=FLH (floor heating), 1=FCU(fan coil unit), 2=RAD(radiator)	1	0	2	1	/
	Zone 2 C-emission	The type of Zone 2 terminal for cooling mode: 0=FLH (floor heating), 1=FCU(fan coil unit), 2=RAD(radiator)	1	0	2	1	/
Heating mode	Enable or disable the heating mode: 0=NO, 1=YES	1	0	1	1	/	

Heating setting	t_T4_Fresh_H	The refresh time of climate-related curves in heating mode	0.5	0.5	6	0.5	Hours
	T4HMAX	The maximum ambient operating temperature in heating mode	25	20	35	1	°C
	T4HMIN	The minimum ambient operating temperature in heating mode	-15	-25	30	1	°C
	dT1SH	The temperature difference for starting the unit (T1)	5	2	20	1	°C
	dTSH	The temperature difference for starting the unit (Ta)	2	1	10	1	°C
	Zone 1 H-emission	The type of Zone 1 terminal for heating mode: 0=FLH (floor heating) 1=FCU(fan coil unit), 2=RAD(radiator)	2	0	2	1	/
	Zone 2 H-emission	The type of Zone 2 terminal for heating mode: 0=FLH (floor heating) 1=FCU(fan coil unit), 2=RAD(radiator)	0	0	2	1	/
	Force defrost	Enable or disable the force defrost: 0=NO, 1=YES.	0	0	1	1	/
AUTO mode setting	T4AUTOCMIN	The minimum operating ambient temperature for cooling in auto mode	25	20	29	1	°C
	T4AUTOHMAX	The maximum operating ambient temperature for heating in auto mode	17	10	17	1	°C
Temp. type setting	Water flow temp.	Enable or disable the Water flow temp.: 0=NO, 1=YES	1	0	1	1	/
	Room temp.	Enable or disable the Room temp.: 0=NO, 1=YES	0	0	1	1	/
	Double zone	Enable or disable the Double zone: 0=NO, 1=YES	0	0	1	1	/
Room thermostat setting	Room thermostat	The style of room thermostat: 0=NO, 1=Mode set, 2=One zone, 3=Double zone	0	0	3	1	/
	Mode set priority	Select the priority mode in Room thermostat: 0=Heating, 1=Cooling	0	0	1	1	/
Other heat source	IBH function	Select the mode of IBH (Internal backup heater) : 0=Heating and DHW, 1=Heating	0 (DHW=valid) 1 (DHW=invalid)	0	1	1	/
	dT1_IBH_ON	The temperature difference between T1S and T1 for starting the backup heater	5	2	10	1	°C
	t_IBH_Delay	The time for which the compressor has run before startup of the first step backup heater	30	15	120	5	Minutes
	T4_IBH_ON	The ambient temperature for starting the backup heater	-5	-15	30	1	°C
	P_IBH1	Power input of IBH1	0.0	0.0	20.0	0.5	kW
	P_IBH2	Power input of IBH2	0.0	0.0	20.0	0.5	kW
	AHS function	Enable or disable the AHS (Auxiliary heating source) function: 0=NO, 1=Heating, 2=Heating and DHW	0	0	2	1	/
	AHS_Pump_I Control	Select the pump operating status when only AHS runs: 0=Run, 1=Not run	0	0	1	1	/
	dT1_AHS_ON	The temperature difference between T1S and T1 for starting the auxiliary heating source	5	2	20	1	°C
	t_AHS_Delay	The time for which the compressor has run before startup of the additional heating source	30	5	120	5	Minutes
	T4_AHS_ON	The ambient temperature for starting the additional heating source	-5	-15	30	1	°C
	EnSwitchPDC	Enable or disable automatic switch of heat pump and auxiliary heating source based on running cost: 0=NO, 1=YES	0	0	1	1	/
	GAS-COST	Price of gas	0.85	0.00	5.00	0.01	price/m ³
ELE-COST	Price of electricity	0.20	0.00	5.00	0.01	price/kWh	

Other heat source	MAX-SETHEATER	Maximum set temperature of additional heating source	80	1	80	1	°C
	MIN-SETHEATER	Minimum set temperature of additional heating source	30	0	79	1	°C
	MAX-SIGHEATER	The voltage corresponding to the maximum set temperature of additional heating source	10	1	10	1	V
	MIN-SIGHEATER	The voltage corresponding to the minimum set temperature of additional heating source	3	0	9	1	V
	TBH function	Enable or disable the TBH (Tank booster heater) function: 0=NO, 1=YES	1	0	1	1	/
	dT5_TBH_OFF	The temperature difference between T5 and T5S (the set water tank temperature) for turning the booster heater off	5	0	10	1	°C
	t_TBH_DELAY	The time for which the compressor has run before startup of the booster heater	30	0	240	5	Minutes
	T4_TBH_ON	The ambient temperature for starting the tank booster heater	5	-5	50	1	°C
	P_TBH	Power input of TBH	2.0	0.0	20.0	0.5	kW
	Solar function	Enable or disable the Solar function: 0=NO, 1=Only solar, 2=Solar and HP (Heat Pump)	0	0	2	1	/
	Solar control	Solar pump (pump_s) control: 0=SL1SL2, 1=Tsolar	0	0	1	1	/
Deltatsol	The temperature deviation for solar function running	10	5	20	1	°C	
Special function	Preheating for floor	Enable or disable floor preheating: 0=NO, 1=YES	0	0	1	1	/
	T1S	The set outlet water temperature during first floor preheating	25	25	35	1	°C
	t_ARSTH	Running time for first floor preheating	72	48	96	12	Hours
	Floor drying up	Enable or disable floor drying: 0=NO, 1=YES	0	0	1	1	/
	t_Dryup	Temp-up days for floor drying	8	4	15	1	Days
	t_Highpeak	Days for floor drying	5	3	7	1	Days
	t_Drydown	Temp-down days for floor drying	5	4	15	1	Days
	t_Drypeak	Outlet water temperature for floor drying	45	30	55	1	°C
	Start time	The start time of floor drying	00:00	0:00	23:30	1/30	h/min
Start date	The start date of floor drying	Current date+1	Current date+1	31/12/2099	1/1/1	dd/mm/yyyy	
Auto restart	Auto restart cooling/heating mode	Enable or disable the auto restart of cooling/heating mode: 0=NO, 1=YES	1	0	1	1	/
	Auto restart DHW mode	Enable or disable the auto restart of DHW mode: 0=NO, 1=YES	1	0	1	1	/
Power input limitation	Power input limitation	The type of power input limitation	1	1	8	1	/
Input definition	M1 M2	Define the function of the M1M2 switch: 0=remote ON/OFF, 1=TBH ON/OFF, 2=AHS ON/OFF	0	0	2	1	/
	Smart grid	Enable or disable the smart grid: 0=NO, 1=YES	0	0	1	1	/
	T1T2	Control options of Port T1T2: 0=NO, 1=RT/Ta_PCB	0	0	1	1	/
	Tbt	Enable or disable the TBT: 0=NO, 1=YES	0	0	1	1	/
	P_X port	Select the function of P_X port: 0=Defrost, 1=Alarm	0	0	1	1	/
Cascade setting	PER_START	Percentage of operating units among all units	10	10	100	10	%
	TIME_ADJUST	Time interval for determining the necessity of unit loading/unloading	5	1	60	1	Minutes

HMI address setting	HMI address for BMS	Set the HMI address code for BMS	1	1	255	1	/
	Stop BIT	Upper computer stop bit: 1=STOP BIT1, 2=STOP BIT2	1	1	2	1	/
Common setting	t_Delay pump	The time for which the compressor has run before startup of the pump	2.0	0.5	20.0	0.5	Minutes
	t1_Antilock pump	The pump anti-lock interval	24	5	48	1	Hours
	t2_Antilock pump run	The pump anti-lock running time	60	0	300	30	Seconds
	t1_Antilock SV	The valve anti-lock interval	24	5	48	1	Hours
	t2_Antilock SV run	The valve anti-lock running time	30	0	120	10	Seconds
	Ta-adj.	The corrected value of Ta inside the wired controller	0	-10	10	1	°C
	Pump_I silent output	The Pump_I max output limitation	100	50	100	5	%
	Energy metering	Enable or disable the energy analysis: 0=NO, 1=YES	1	0	1	1	/
	Pump_O	Additional circulation pump operation: 0=ON (keep running) 1=Auto (controlled by the unit)	0	0	1	1	/
	Glycol	Glycol application: 0=Without glycol, 1=With glycol	0	0	1	1	/
	Glycol concentration	Glycol added concentration	10	10	30	5	%
Pump_I minimum output	Circulation pump Pump_I operating lowest limit	30	30	80	5	%	
Intelligent function settings	Energy correction	Correction for Energy metering	0	-50	50	5	%
	Sensor backup mode	Sensor backup operation function, 0 =NO, 1=YES	1	0	1	1	/

NOTE

- Please set P_IBH1, P_IBH2, P_TBH according to the field installation. If the values are different with the actual values, the energy metering calculation could deviate from actual situation.
- There are some items that are invisible if the function is disabled or unavailable.
- Please define Solar function as NO, otherwise Eb error code will appear.

12 COMMISSIONING

Test run is used to confirm the functionality of the valves, air purge, circulation pump operation, cooling, heating and domestic water heating.

Test run

Point check >|

Air purge >

Circulated pump running >

Cooling running >

Test run

Heating running >|

Cooling running >

DHW running >

Checklist during commissioning

<input type="checkbox"/>	Test run for the actuator
<input type="checkbox"/>	Air purge
<input type="checkbox"/>	Test run for operation
<input type="checkbox"/>	Check of the minimum flow rate

12.1 Test run for the actuator

NOTE

During the commissioning of the actuator, the protection function of the unit is disabled. Excessive use may damage components.

Why

Check whether each actuator is in good working conditions.

What - Actuator List

No.	Name		Note
1	SV2	Three-way valve 2	
2	SV3	Three-way valve 3	
3	PUMP_I	Integrated circulation pump	
4	PUMP_O	Additional circulation pump(for Zone 1)	
5	PUMP_C	Zone 2 pump	
6	IBH	Internal backup heater	
7	AHS	Additional heat source	
8	SV1	Three-way valve 1	Invisible if DHW is disabled
9	PUMP_D	DHW pump	Invisible if DHW is disabled
10	PUMP_S	Solar heating loop circulation pump	Invisible if DHW is disabled
11	TBH	Tank booster heater	Invisible if DHW is disabled

How

1	Go to "FOR SERVICEMAN" (Refer to 11.5 Field settings).
2	Find "Test run" and enter the process.
3	Find "Point check" and enter the process.
4	Select the actuator, and press <input type="radio"/> to activate or deactivate the actuator. <ul style="list-style-type: none"> The status ON means the actuator is activated, and OFF means the actuator is deactivated.

NOTE

When you return to the upper layer, all actuators turn OFF automatically.

12.2 Air purge

Why

To purge out the remaining air in the water loop.

How

1	Go to "FOR SERVICEMAN" (Refer to 11.5 Field settings).
2	Find "Test run and enter the process.
3	Find "Air purge" and enter the process.
4	Select "Air purge" and press <input type="radio"/> to activate or deactivate the air purge function. <ul style="list-style-type: none"> <input checked="" type="radio"/> means the air purge function is activated, and <input type="radio"/> means the air purge function is deactivated.

Besides

"Air vent pump_i output"	To set pump_i output. The higher the value is, the pump gives a higher output.
"Air vent running time"	To set the duration of air purge. When the set time is due, air purge is deactivated.
"Status check"	Additional operation parameters can be found.

12.3 Test run

Why

Check whether the unit is in good working conditions.

What

Circulated pump operation
 Cooling operation
 Heating operation
 DHW operation

How

1	Go to "FOR SERVICEMAN" (Refer to 11.5 Field settings)
2	Find "Test run" and enter the page.
3	Find "Other" and enter the process.
4	Select "XXXX"* and press <input type="radio"/> to run the test. During test, press <input type="radio"/> , select OK and confirm to return to the upper layer. <ul style="list-style-type: none"> * - Four performance test options are shown in What.

NOTE

In performance test, the target temperature is preset and cannot be changed.
 If the outdoor temperature is outside the range of operating temperature, the unit may not operate or may not deliver the required capacity.
 In circulated pump operation, If the flow rate is out of recommended flow rate range, please make proper change of the installation, and ensure that the flow rate in the installation is guaranteed in all conditions.

12.4 Check of the minimum flow rate

1	Check the hydraulic configuration to find out the space heating loops that can be closed by mechanical, electronic, or other valves.
2	Close all space heating loops that can be closed.
3	Start and operate the circulation pump (See "12.3 Test Run").
4	Read out the flow rate ^(a) and modify the bypass valve settings until the set value reaches the minimum flow rate required + 2 l/min.

(a) During pump trail run, the unit can operate below the minimum required flow rate.

13 HAND-OVER TO THE USER

Once the trail run is finished and the unit operates properly, please make sure the following is clear for the user:

- Fill the installer setting table (in the OPERATION MANUAL) with the actual settings.
- Empty the error history in the HMI before hand-over to the user.
- It is highly recommended to do the WLAN connection of the unit. You can read more information in the APP.
- Make sure that the user has the printed documentation and ask him/her to keep it for future reference.
- Explain to the user how to properly operate the system and what to do in case of problems.

-Basic operation guidelines can be found in the OPERATION MANUAL.

-For additional information about operation, see 13.2 Additional Operation Reference.

- Show the user what to do for the maintenance of the unit.
- Explain to the user about energy saving tips as described below.

13.1 Energy saving tips

Tips about room temperature

- Make sure the desired room temperature is NEVER too high (in heating mode) or too low (in cooling mode), and ALWAYS set it according to your actual needs. An rise/drop of one degree centigrade can save up to 6 % of heating/cooling costs.
- Do NOT increase/decrease the desired room temperature to speed up space heating/cooling as such operation cannot accelerate the heating/cooling process.
- When your system layout contains slow heat emitters (such as underfloor heating), avoid large fluctuations of the desired room temperature and do NOT drop or rise the room temperature excessively. Otherwise, it will take more time and energy to heat up/cool down the room again.
- Use a weekly schedule to meet your normal space heating or cooling needs. If necessary, you can easily deviate from the schedule:
 - 1) For shorter periods: You can override the scheduled room temperature until the next scheduled action starts. For example, you can do this when you have a party, or when you are leaving for a couple of hours.
 - 2) For longer periods: You can use the holiday mode.

Tips about DHW tank temperature

- Use a weekly schedule to meet your normal domestic hot water needs (only in scheduled mode).
- Program to heat up the DHW tank to a preset value during the night, because the space heating demand during such period is low.
- If heating up the DHW tank only at night is not sufficient, program to additionally heat up the DHW tank to a preset value during the day.
- Make sure the desired DHW tank temperature is NOT too high. For example, after installation, lower the DHW tank temperature daily by 1 °C and check if you still have enough hot water.
- Program to turn ON the domestic hot water pump only during periods of the day when instant hot water is necessary, such as in the morning and evening.

13.2 Additional operation reference

13.2.1 Mode

What

Set the unit operation mode for room comfort.

- Three modes in all – Space heating mode, space cooling mode, and auto mode.

AUTO mode	The unit will select the operation mode automatically based on the outdoor ambient temperature and some settings in "FOR SERVICEMEN". <ul style="list-style-type: none"> • This icon is invisible if either the heating function or cooling function is disabled.
Heating	The icon of heating is invisible if the heating function is disabled.
Cooling	The icon of cooling is invisible if the cooling function is disabled.

13.2.2 Schedule

What

Make unit operation plans.

- This function is based on the current time displayed on the HMI. Make sure the time is correct.

Conflicts and operation priority

- 1) A daily schedule and a weekly schedule can work simultaneously.
- 2) For all schedules, timers (if more than one) for the same zone or appliance must be different, and the operation mode of Zone 1 and Zone 2 in the same time setting must be the same. Otherwise, the most recent setting is invalid, and a notice window appears.
- 3) When the unit is in Holiday away or Holiday home mode, the daily timer, weekly timer and temperature curve function (11.2.3 Weather temp. setting) become invalid and will not recover until the unit quits Holiday away and Holiday home mode.
- 4) If Holiday away and Holiday home mode are active simultaneously, the date for both the modes cannot be overlapped. Otherwise, the most recent setting is invalid, and a notice window appears.

More

- 1) All daily schedules and weekly schedules become inactive, the set time turns to 0:00, and the set temperature turns to 24 °C in case of any change of the temperature control mode .
- 2) The unit runs disinfection based on the settings of 11.5.1 DHW setting, if the disinfection function in Holiday away mode is inactive.
- 3) In case of power failure during Holiday away or Holiday home mode, the unit will run in Holiday away or Holiday home mode after power restoration if the current date is still within the period for Holiday away or Holiday home mode.
- 4) If the mode setting is OFF, the set temperature turns to 0 °C.

13.2.3 Weather temp. setting

What

Allow the set water temperature to regulate depending on the outdoor ambient temperature.

- This function is only applicable to space heating and space cooling. When the function is active, the unit will apply the temperature curve if the current operation mode is set the same as that of the activated function.
- Three types of curves in all – Standard, ECO, Custom.

Illustration of temperature curve

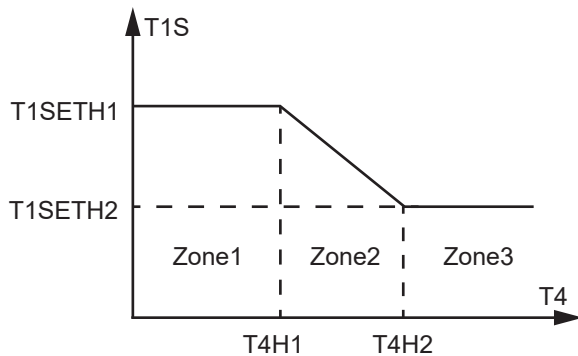

T1S – set water temperature

T4 – outdoor ambient temperature

In Zone 1 and Zone 3, the set water temperature remains stable despite the change of the outdoor ambient temperature. In Zone 2, the set water temperature regulates depending on the outdoor ambient temperature.

Standard

Up to 8 curves are preset by the manufacturer, and the parameter values are as below.

For heating:

	$T4 < 0$	$0 \leq T4 < 20$	$T4 \geq 20$
1-T1S	$0.175 * (0 - T4) + 25$	$0.25 * (20 - T4) + 20$	20
2-T1S	$0.35 * (0 - T4) + 30$	$0.5 * (20 - T4) + 20$	20
3-T1S	$0.525 * (0 - T4) + 35$	$0.75 * (20 - T4) + 20$	20
4-T1S	$0.63 * (0 - T4) + 38$	$0.9 * (20 - T4) + 20$	20
5-T1S	$0.875 * (0 - T4) + 45$	$1.25 * (20 - T4) + 20$	20
6-T1S	$0.98 * (0 - T4) + 48$	$1.4 * (20 - T4) + 20$	20
7-T1S	$1.225 * (0 - T4) + 55$	$1.75 * (20 - T4) + 20$	20
8-T1S	$1.4 * (0 - T4) + 60$	$2 * (20 - T4) + 20$	20

Illustration of all 8 curves

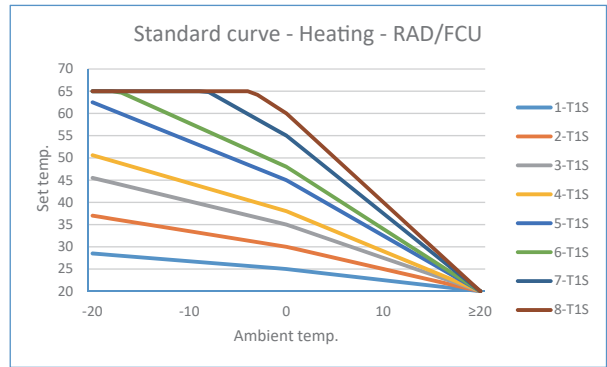
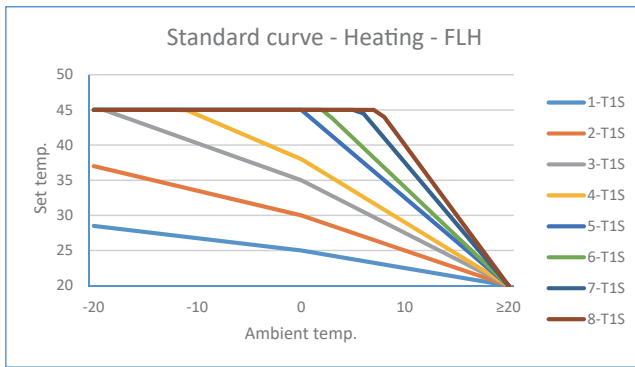

For cooling (FCU – fan coil application):

T4	-10≤T4 < 15	15≤T4 < 22	22≤T4 < 30	30≤T4
1-T1S	16	11	8	5
2-T1S	17	12	9	6
3-T1S	18	13	10	7
4-T1S	19	14	11	8
5-T1S	20	15	12	9
6-T1S	21	16	13	10
7-T1S	22	17	14	11
8-T1S	23	18	15	12

For cooling (RAD – radiator application, FLH – underfloor heating):

T4	-10≤T4 < 15	15≤T4 < 22	22≤T4 < 30	30≤T4
1-T1S	20	18	18	18
2-T1S	21	19	18	18
3-T1S	22	20	19	18
4-T1S	23	21	19	18
5-T1S	24	21	20	18
6-T1S	24	22	20	19
7-T1S	25	22	21	19
8-T1S	25	23	21	20

Illustration of all 8 curves

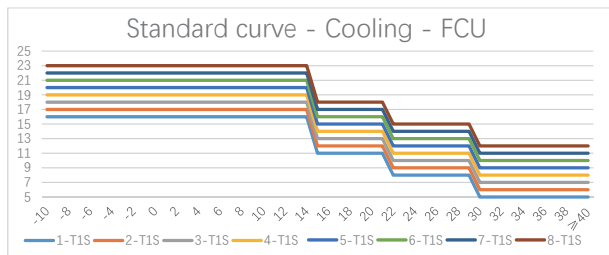
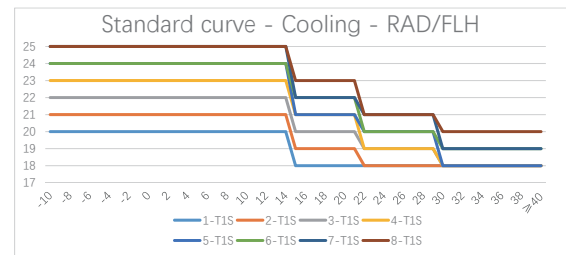

Illustration of all 8 curves



About Temperature offset

It makes the overall set water temperature of the temperature curve increase or decrease. The temperature curve rises or drops in the illustration.

ECO

NOTE

ECO is available for Zone 1 heating mode only.

T4	≤-20	-19	-18	-17	-16	-15	-14	-13	-12	-11	-10	-9	-8	-7	-6	-5	-4	-3	-2	-1	0
1-T1S	29	29	29	29	28	28	28	28	28	28	28	28	27	27	27	27	27	27	25	25	25
2-T1S	32	32	32	32	31	31	31	31	31	31	31	31	30	30	30	30	30	30	30	30	30
3-T1S	38	38	38	38	38	37	37	37	37	37	37	36	36	36	36	36	36	35	35	35	35
4-T1S	40	40	40	40	39	39	39	39	39	39	39	39	38	38	38	38	38	38	38	38	37
5-T1S	45	45	45	45	44	44	44	44	44	44	44	44	43	43	43	43	43	43	43	43	42
6-T1S	48	48	48	48	47	47	47	47	47	47	47	47	46	46	46	46	46	46	46	46	45
7-T1S	52	52	52	52	51	51	51	51	51	51	51	51	50	50	50	50	50	50	50	50	49
8-T1S	55	55	55	55	54	54	54	54	54	54	54	54	53	53	53	53	53	53	53	53	52
T4	1	2	3	4	5	6	7	8	9	10	11	12	13	14	15	16	17	18	19	≥20	
1-T1S	24	24	24	24	23	23	23	23	22	22	22	22	21	21	21	21	20	20	20	20	20
2-T1S	29	29	28	28	27	27	26	26	25	25	24	24	23	23	22	22	21	21	20	20	20
3-T1S	34	33	32	32	31	30	29	29	28	27	26	26	25	24	23	23	22	21	20	20	20
4-T1S	37	36	35	34	33	32	31	30	29	29	28	27	26	25	24	23	22	21	20	20	20
5-T1S	42	42	41	40	38	37	36	35	33	32	31	30	28	27	26	25	23	22	21	20	20
6-T1S	45	45	43	42	41	39	38	36	35	34	32	31	29	28	27	25	24	22	21	20	20
7-T1S	49	49	49	48	46	44	42	41	39	37	35	34	32	30	28	27	25	23	21	20	20
8-T1S	52	52	52	52	50	48	46	44	42	40	38	36	34	32	30	28	26	24	22	20	20

Illustration of all 8 curves

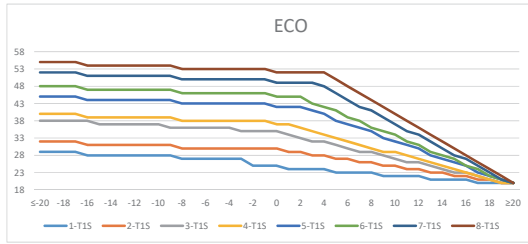

You can see “ECO timer” at the bottom of the page. You can set the start time and end time of the timer and activate the timer. If the timer is active, the unit will execute the ECO curve only during the set period of the timer. If the timer is inactive, the unit will execute the ECO curve all the way.

Custom

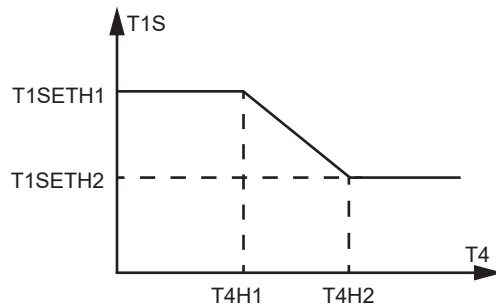

T1S – Set water temperature
T4 – Outdoor ambient temperature
T1SETH1, T1SETH2, T4H1, and T4H2 can be adjusted.

NOTE

The illustration on HMI is for reference only. If the set T1SETH1 is lower than T1SETH2 or T4H2 is lower than T4H1, the unit will reverse T1SETH1 and T1SETH2, T4H1 and T4H2 automatically.

13.2.4 DHW setting

NOTE

Invisible if DHW MODE is disabled.

What

More settings of DHW.

Disinfection

- When the unit is running in disinfection mode with DHW on, if you turn off DHW on the home page, the unit will ask if you want to disable the disinfection. If you confirm the disablement, a notice window will appear.

NOTE

If any timer of DHW OFF is during the disinfection working. Then the disinfection will be turned off automatically without any notice.

- When the unit is running in disinfection mode with DHW off, if you turn on DHW on the home page, the disinfection continues.

Tank heater

The tank heater and backup heater cannot operate simultaneously. The most recent setting is valid while the previous setting becomes invalid

- For instance, when the backup heater is valid and running, if the tank heater is turned off, the backup heater stops running.

13.2.5 Options

What

More general settings.

Silent mode

The start time and end time of the silent mode timer cannot be identical.

If two silent mode timers are activated simultaneously, the date of both the timers cannot be overlapped. Otherwise, the most recent setting is invalid, and a notice window appears.

Backup heater

Invisible if IBH and AHS are disabled.

WLAN setting

In case of any change of the WIFI name, the unit will lost WLAN connection and need to be reconnected.

Force defrost

Invisible if the unit is running in cooling mode.

13.2.6 Unit status

What

More information of the unit and its operation status.

Operating parameter

The run time is rounded down. For instance, if the unit is hour, and the actual run time is 0.5 h, the displayed value is 0.

Energy metering

For accumulated data(Day, Week, Month, Year),

1) The start time is the beginning of that day, week, month, year.

2) If the time of HMI is reset and there is data logging from the beginning of that day, week, month, year, the calculation will start from the beginning of that day, week, month, year.

3) If the time of HMI is reset and there is no data logging from the beginning of that day, week, month, or year, the calculation will start from the time when the resetting occurs.

For Historical data,

- It records up to 10-year data. For instance, if the unit starts running from 2023, when it comes to 2035, you can check the data only from 2025 to 2035.

13.2.7 Error info

What

Error history of the unit.

The first column shows the unit number, if slave units are available.

Press the Menu button for 5 seconds to clear all error records.

13.2.8 FAQ

What

Assistance for common questions.

14 TECHNICAL SPECIFICATIONS

Indoor unit model	100/190 3 kW heater	100/240 3 kW heater	160/240 3 kW heater
Power supply	220-240 V~ 50 Hz		
Rated input	3 095 W		
Rated Current	13.5 A		
Norminal capacity	Refer to the technical data		
Dimensions (W×H×D)[mm]	600 x 1 683 x 600	600 x 1 943 x 600	
Packing (W×H×D)[mm]	730 x 1 920 x 730	730 x 2 180 x 730	
Heat exchanger	Plate heat exchanger		
Electric heater	3 000 W		
Internal water volume	13.5 L		
Rated water pressure	0.3 MPa		
Filter mesh	60		
Min. water flow (flow switch)	6 L/min	10 L/min	
Pump			
Type	DC inverter		
Max. head	9 m		
Power input	5 W to 90 W		
Expansion vessel			
Volume	8 L		
Max. operating pressure	0.3 MPa		
Pre-charge pressure	0.10 MPa		
Weight			
Net weight	143 kg	157 kg	159 kg
Gross weight	164 kg	178 kg	180 kg
Connections			
Refrigerant pipe(gas/liquid)	Φ15.9 / Φ9.52		
Water inlet/outlet	R1"		
Drain connection	Φ25		
Operation range			
Outlet water(heating model)	+12 °C to +65 °C		
Outlet water(cooling model)	+5 °C to +30 °C		
Domestic hot water	+12 °C to +60 °C		
Space heating/cooling water inlet water pressure	0.1 MPa to 0.25 MPa		
Domestic cold water pressure	0.15 MPa to 0.3 MPa		
Ambient temperature(Indoor side)	+5 °C to +35 °C		

Indoor unit model	100/190 6 kW heater	100/240 6 kW heater	160/240 6 kW heater	100/190 9 kW heater	100/240 9 kW heater	160/240 9 kW heater
Power supply	220-240 V~ 50 Hz			380-415 V 3N~ 50 Hz		
Rated input	6 095 W			9 095 W		
Rated Current	26.5 A			13.5 A		
Norminal capacity	Refer to the technical data					
Dimensions (W×H×D)[mm]	600 x 1 683 x 600	600 x 1 943 x 600		600 x 1 683 x 600	600 x 1 943 x 600	
Packing (W×H×D)[mm]	730 x 1 920 x 730	730 x 2 180 x 730		730 x 1 920 x 730	730 x 2 180 x 730	
Heat exchanger	Plate heat exchanger					
Electric heater	6 000 W			9 000 W		
Internal water volume	13.5L					
Rated water pressure	0.3 MPa					
Filter mesh	60					
Min. water flow (flow switch)	6 L/min		10 L/min	6 L/min		10 L/min
Pump						
Type	DC inverter					
Max. head	9 m					
Power input	5 W to 90 W					
Expansion vessel						
Volume	8L					
Max. operating pressure	0.3 MPa					
Pre-charge pressure	0.10 MPa					
Weight						
Net weight	143 kg	157 kg	159 kg	143 kg	157 kg	159 kg
Gross weight	164 kg	178 kg	180 kg	164 kg	178 kg	180 kg
Connections						
Refrigerant pipe (gas/liquid)	Φ15.9 / Φ9.52					
Water inlet/outlet	R1"					
Drain connection	Φ25					
Operation range						
Outlet water(heating model)	+12 °C to +65 °C					
Outlet water(cooling model)	+5 °C to +30 °C					
Domestic hot water	+12 °C to +60 °C					
Space heating/cooling water inlet water pressure	0.1 MPa to 0.25 MPa					
Domestic cold water pressure	0.15 MPa to 0.3 MPa					
Ambient temperature (Indoor side)	+5 °C to +35 °C					

15 TROUBLE SHOOTING

This section provides useful information for diagnosing and correcting certain troubles which may occur in the unit. This troubleshooting and related corrective actions may only be carried out by your local technician.

15.1 General guidelines

Before starting the troubleshooting procedure, carry out a thorough visual inspection of the unit and look for obvious defects such as loose connections or defective wiring.

WARNING

When carrying out an inspection on the switch box of the unit, always make sure that the main switch of the unit is switched off.

When a safety device was activated, stop the unit and find out why the safety device was activated before resetting it. Under no circumstances can safety devices be bridged or changed to a value other than the factory setting. If the cause of the problem cannot be found, call your local dealer.

If the pressure relief valve is not working correctly and is to be replaced, always reconnect the flexible hose attached to the pressure relief valve to avoid water dripping out of the unit!

15.2 General symptoms

Symptom 1: The unit is turned on but the unit is not heating or cooling as expected

POSSIBLE CAUSES	CORRECTIVE ACTION
The temperature setting is not correct.	Check the parameters. T4HMAX, T4HMIN in heat mode. T4CMAX, T4CMIN in cool mode. T4DHWMAX, T4DHWMIN in DHW mode.
The water flow is too low.	<ul style="list-style-type: none"> • Check that all shut off valves of the water circuit are in the right position. • Check if the water filter is plugged. • Make sure there is no air in the water system. • Check on the manometer that there is sufficient water pressure. The water pressure must be >1 bar (water is cold). • Make sure that the expansion vessel is not broken. • Check that the resistance in the water circuit is not too high for the pump.
The water volume in the installation is too low.	Make sure that the water volume in the installation is above the minimum required value (refer to "8.6 Water volume and sizing expansion vessels").

Symptom 2: The unit is turned on but the compressor is not starting (space heating or domestic water heating)

POSSIBLE CAUSES	CORRECTIVE ACTION
The unit maybe operate out of its operation range (the water temperature is too low).	<p>In case of low water temperature, the system utilizes the backup heater to reach the minimum water temperature first (12 °C).</p> <ul style="list-style-type: none"> • Check that the backup heater power supply is correct. • Check that the backup heater thermal fuse is closed. • Check that the backup heater thermal protector is not activated. • Check that the backup heater contactors are not broken.

Symptom 3: Pump is making noise (cavitation)

POSSIBLE CAUSES	CORRECTIVE ACTION
There is air in the system.	Purge air.
Water pressure at pump inlet is too low.	<ul style="list-style-type: none"> • Check on the manometer that there is sufficient water pressure. The water pressure must be > 1 bar (water is cold). • Check that the manometer is not broken. • Check that the expansion vessel is not broken. • Check that the setting of the pre- pressure of the expansion vessel is correct (refer to 8.6 Water volume and sizing expansion vessels").

Symptom 4: The water pressure relief valve opens

POSSIBLE CAUSES	CORRECTIVE ACTION
The expansion vessel is broken.	Replace the expansion vessel.
The filling water pressure in the installation is higher than 0.3 MPa.	Make sure that the filling water pressure in the installation is about 0.10~0.20 MPa (refer to "8.6 Water volume and sizing expansion vessels").

Symptom 5: The water pressure relief valve leaks

POSSIBLE CAUSES	CORRECTIVE ACTION
Dirt is blocking the water pressure relief valve outlet.	<p>Check for correct operation of the pressure relief valve by turning the red knob on the valve counter clockwise:</p> <ul style="list-style-type: none"> • If you do not hear a clacking sound, contact your local dealer. • In case the water keeps running out of the unit, close both the water inlet and outlet shut-off valves first and then contact your local dealer.

Symptom 6: Space heating capacity shortage at low outdoor temperatures

POSSIBLE CAUSES	CORRECTIVE ACTION
Backup heater operation is not activated.	<p>Check that the "OTHER HEATING SOURCE/ BACKUP HEATER" is enabled, see "11.5 Field settings" Check whether or not the thermal protector of the backup heater has been activated (refer to "Controls parts for backup heater (IBH)"). Check if booster heater is running, the backup heater and booster heater can't operate simultaneously.</p>
Too much heat pump capacity is used for heating domestic hot water (applies only to installations with a domestic hot water tank).	<p>Check that the "t_DHWHP_MAX" and "t_DHWHP_RESTRICT" are configured appropriately:</p> <ul style="list-style-type: none"> • Make sure that the "DHW PRIORITY" in the user interface is disabled. • Enable the "T4_TBH_ON" in the user interface/FOR SERVICEMAN to activate the booster heater for domestic water heating.

Symptom 7: Heat mode can't change to DHW mode immediately

POSSIBLE CAUSES	CORRECTIVE ACTION
Volume of tank is too small and the location of water temperature probe not high enough	<ul style="list-style-type: none"> • Set "dT1S5" to maximum value, and set "t_DHWHP_RESTRICT" to minimum value. • Set dT1SH to 2 °C. • Enable TBH, and TBH should be controlled by the outdoor unit. • If AHS is available, turn on first, if requirement for turn heat pump on is full filled, the heat pump will turn on. • If both TBH and AHS are not available, try to change the position of T5 probe.

15.3 Error codes

When a safety device is activated, an error code(which does't include external failure) will be displayed on the user interface.

A list of all errors and corrective actions can be found in the table below.

Reset the safety by turning the unit OFF and back ON.

In case this procedure for resetting the safety is not successful, contact your local dealer.

ERROR CODE	MALFUNCTION OR PROTECTION	FAILURE CAUSE AND CORRECTIVE ACTION
<i>E0</i>	Water flow fault(after 3 times E8)	<ol style="list-style-type: none"> 1.The wire circuit is short connected or open. Reconnect the wire correctly. 2. Water flow rate is too low. 3. Water flow switch is failed, switch is open or close continuously, change the water flow switch.
<i>E2</i>	Communication fault between controller and hydraulic module	<ol style="list-style-type: none"> 1.Wire doesn't connect between wired controller and unit. connect the wire. 2.Communication wire sequence is not right. Reconnect the wire in the right sequence. 3.Check whether there is a high magnetic field or high power interfere, such as lifts, large power transformers, etc.. 4. To add a barrier to protect the unit or to move the unit to the other place.
<i>E3</i>	Hydro-box water outlet temperature sensor (T1) fault.	<ol style="list-style-type: none"> 1.Check the resistance of the sensor 2.The T1 sensor connector is loosen. Reconnect it. 3.The T1 sensor connector is wet or there is water in. remove the water, make the connector dry. Add waterproof adhesive. 4.The T1 sensor failure, change a new sensor.
<i>E4</i>	Water tank temperature sensor (T5) fault.	<ol style="list-style-type: none"> 1.Check the resistance of the sensor 2.The T5 sensor connector is loosen. Reconnect it. 3.The T5 sensor connector is wet or there is water in. remove the water, make the connector dry. Add waterproof adhesive 4.The T5 sensor failure, change a new sensor. 5. If you want to close the domestic water heating when T5 sensor do not connected to the system, then T5 sensor can not be detected, refer to 11.5.1 "DHW MODE SETTING"
<i>E7</i>	Balance tank temperature sensor (Tbt) fault.	<ol style="list-style-type: none"> 1. Check the resistance of the sensor. 2. The Tbt1 sensor connector is loosen,reconnect it. 3. The Tbt1 sensor connector is wet or there is water in,remove the water ,make the connector dry.Add waterproof adhesive. 4. The Tbt1 sensor failure,change a new sensor."
<i>E8</i>	Water flow fault	<p>Check that all shut off valves of the water circuit are completely open.</p> <ol style="list-style-type: none"> 1. Check if the water filter needs cleaning. 2. Refer to "9.5 Filling water" 3. Make sure there is no air in the system(purge air). 4. Check the water pressure. The water pressure must be >1 bar. 5. Check that the pump speed setting is on the highest speed. 6. Make sure that the expansion vessel is not broken. 7. Check that the resistance in the water circuit is not too high for the pump (refer to "11.4 Setting the pump"). 8. If this error occurs at defrost operation (during space heating or domestic water heating), make sure that the backup heater power supply is wired correctly and that fuses are not blown. 9. Check that the pump fuse and PCB fuse are not blown.

ERROR CODE	MALFUNCTION OR PROTECTION	FAILURE CAUSE AND CORRECTIVE ACTION
<i>Eb</i>	Reserved	Reserved Make sure Wired controller>>For serviceman>>Other heat source>>Solar function = NO, otherwise Eb error code will appear.
<i>Ed</i>	Hydro-box plate heat exchanger water inlet temperature sensor (Tw_in) fault.	<ol style="list-style-type: none"> 1.Check the resistance of the sensor 2.The Tw_in sensor connector is loosen. Reconnect it. 3.The Tw_in sensor connector is wet or there is water in. remove the water, make the coSnnector dry. Add waterproof adhesive 4.The Tw_in sensor failure, change a new sensor.
<i>EE</i>	Hydro-box PCB EEPROM fault.	<ol style="list-style-type: none"> 1. The EEprom parameter is error, rewrite the EEprom data. 2. EEprom chip part is broken, change a new EEprom chip part. 3. Main control board of hydraulic module is broken, change a new PCB.
<i>HO</i>	Communication fault between hydro-box and outdoor unit.	<ol style="list-style-type: none"> 1.Wire doesn't connect between main control board PCB B and main control board of hydraulic module. connect the wire. 2.Communication wire sequence is not right. Reconnect the wire in the right sequence. 3. Check whether there is a high magnetic field or high power interfere, such as lifts, large power transformers, etc.. To add a barrier to protect the unit or to move the unit to the other place.
<i>H2</i>	Plate heat exchanger outlet(heat) refrigerant temperature sensor(T2) fault.	<ol style="list-style-type: none"> 1.Check the resistance of the sensor 2.The T2 sensor connector is loosen. Reconnect it. 3.The T2 sensor connector is wet or there is water in. remove the water, make the connector dry. Add waterproof adhesive 4. The T2 sensor failure, change a new sensor.
<i>H3</i>	Plate heat exchanger inlet(heat) refrigerant temperature sensor(T2B) fault.	<ol style="list-style-type: none"> 1.Check the resistance of the sensor. 2.The T2B sensor connector is loosen. Reconnect it. 3.The T2B sensor connector is wet or there is water in. remove the water, make the connector dry. Add waterproof adhesive 4. The T2B sensor failure, change a new sensor.
<i>H5</i>	Room temperature sensor (Ta) fault.	<ol style="list-style-type: none"> 1.Check the resistance of the sensor. 2. The Ta sensor is in the interface. 3. The Ta sensor failure, change a new sensor or change a new interface, or reset the Ta, connect a new Ta from the hydraulic module PCB.
<i>H9</i>	Zone 2 water flow temperature sensor (Tw2) fault.	<ol style="list-style-type: none"> 1.Check the resistance of the sensor. 2. The Tw2 sensor connector is loosen. Reconnect it. 3.The Tw2 sensor connector is wet or there is water in. Remove the water, make the connector dry. add waterproof adhesive. 4. The Tw2 sensor failure, change a new sensor.
<i>HA</i>	Hydro-box plate heat exchanger water outlet temperature sensor (Tw_out) fault.	<ol style="list-style-type: none"> 1. The TW_out sensor connector is loosen. Reconnect it. 2.The TW_out sensor connector is wet or there is water in. remove the water, make the connector dry. add waterproof adhesive. 3. The TW_out sensor failure, change a new sensor.
<i>Hb</i>	Three times "PP" protection and Tw_out < 7°C	The same to "PP".

ERROR CODE	MALFUNCTION OR PROTECTION	FAILURE CAUSE AND CORRECTIVE ACTION
<i>Hd</i>	The communication fault between master unit and slave unit.	<ol style="list-style-type: none"> 1.The signal wires of slave units and master unit are not effectively connected. After checking all signal wires are well connected, and making sure there is no strong electricity or strong magnetic interference, power on again; 2.There are two or more outdoor unit connected to the wired controller. After removing the excess wired controller and keep only the wired controller of the master unit, power on again; 3.The power-on interval between the master unit and the slave unit is longer than 2min. After ensuring that the interval between the power-on of all the master units and slave units is less than 2min, power on again; 4.The addresses of master unit and slave units are repeated: by pressing the SW2 button on main board once on slave units, the address code of the slave unit will be displayed on the digital tube (Normally address code, one of 1, 2, 3 ... 15 will be shown on main board), check whether there is a duplicate address. If there is a duplicate address code, after powering off the system,set the S4-1 to "ON"on master outdoor unit main board or the salve outdoor unit main board which display "Hd" error(refer to 10.2.1 FUNCTION SEETING).Power on again,all the units last for 5 minutes without "Hd" error, power off again and set the S4-1 to "OFF". The system will recover.
<i>HE</i>	The communication fault between indoor unit and Ta/room thermostat transfer PCB.	RT/Ta PCB is set to be valid on user interface but thermostat transfer board is not connected or the communication between thermostat transfer board and main board is not effectively connected. If thermostat transfer board is not needed, set the RT/Ta PCB to invalid. If thermostat transfer board is needed, please connect it to main board and make sure the communication wire is connected well and there is no strong electricity or strong magnetic interference.
<i>PS</i>	Tw_out - Tw_in value high protection.	<ol style="list-style-type: none"> 1. Check that all shut off valves of the water circuit are completely open. 2. Check if the water filter needs cleaning. 3. Refer to "9.5Filling water" 4. Make sure there is no air in the system (purge air). 5. Check the water pressure. The water pressure must be >1 bar(water is cold). 6. Check that the pump speed setting is on the highest speed. 7. Make sure that the expansion vessel is not broken. 8. Check that the resistance in the water circuit is not too high for the pump. (refer to " 10.4 The circulation pump").
<i>Pb</i>	Anti-freeze mode	Unit will return to the normal operation automatically.
<i>PP</i>	Tw_out - Tw_in unusual protection	<ol style="list-style-type: none"> 1.Check the resistance of the two sensor. 2.Check the two sensors locations. 3.The water inlet/outlet sensor wire connector is loosen. Reconnect it. 4.The water inlet/outlet (TW_in /TW_out) sensor is broken, Change a new sensor. 5.Four-way valve is blocked. Restart the unit again to let the valve change the direction. 6.Four-way valve is broken, change a new valve.
<i>CL</i>	Water pump communication wire fault.	The communication line of the water pump is not properly connected to the main control board of indoor unit. connect the wire.

ERROR CODE	MALFUNCTION OR PROTECTION	FAILURE CAUSE AND CORRECTIVE ACTION
<i>E_L</i>	Communication fault between hydraulic module and MH-kit	1. Wire doesn't connect between main control board of indoor unit and MH-kit. connect the wire. 2. Communication wire sequence is not right. Reconnect the wire in the right sequence. 3. Whether there is a high magnetic field or high power interfere, such as lifts, large power transformers, etc.. To add a barrier to protect the unit or to move the unit to the other place.

 **CAUTION**

In winter, if the unit has E0 and Hb failure and the unit is not repaired in time, the water pump and pipeline system may be damaged by freezing, so E0 and Hb failure must be repaired in time.

16 SAFETY PRECAUTION ABOUT THE APPLIANCES USING FLAMMABLE REFRIGERANT

⚠ WARNING





The following precautions should be complied with when installation, service, maintenance and repair, and decommissioning of appliances using flammable refrigerant.

16.1 General

This appliance employed A2L flammable refrigerant R32.

The appliance shall be stored so as to prevent mechanical damage from occurring.

16.2 Symbols

	WARNING	This symbol shows that this appliance used a flammable refrigerant. If the refrigerant is leaked and exposed to an external ignition source, there is a risk of fire.
	CAUTION	This symbol shows that the manual should be read carefully.
	CAUTION	This symbol shows that only a competent service personnel should be handling this equipment with reference to the technical manual.
	CAUTION	This symbol shows that information is available such as the operating manual or installation manual.

⚠ WARNING

Do not use means to accelerate the defrosting process or to clean, other than those recommended by the manufacturer.

The appliance shall be stored in a room without continuously operating ignition sources (for example: open flames, an operating gas appliance or an operating electric heater).

Do not pierce or burn.

Be aware that refrigerants might not contain an odour.

16.3 Installation

16.3.1 Qualification of workers

⚠ WARNING

Refer to Target group described in chapter 2 SAFETY PRECAUTION.

Every working procedure that affects safety means shall only be carried out by competent persons.

Examples for such working procedures are:

- breaking into the refrigerating circuit;
- opening of sealed components;
- opening of ventilated enclosures.

16.3.2 General

⚠ WARNING

Protection devices, piping and fittings shall be protected as far as possible against adverse environmental effects, for example the danger of water collecting and freezing in relief pipes or the accumulation of dirt and debris;

Provision shall be made for expansion and contraction of long runs of piping;

Piping in refrigerating systems shall be so designed and installed as to minimize the likelihood of hydraulic shock damaging the system;

Steel pipes and components shall be protected against corrosion with a rustproof coating before applying any insulation;

16.4 Information on servicing

16.4.1 General

⚠ CAUTION

Servicing shall be performed only as recommended by the manufacturer.

16.4.2 Checks to the area

Prior to beginning work on systems containing flammable refrigerants, safety checks are necessary to ensure that the risk of ignition is minimised. For repair to the refrigerating system, Clause 17.4.3 to Clause 17.4.7 shall be completed prior to conducting work on the system.

16.4.3 Work procedure

Work shall be undertaken under a controlled procedure so as to minimise the risk of a flammable gas or vapour being present while the work is being performed.

16.4.4 General work area

All maintenance staff and others working in the local area shall be instructed on the nature of work being carried out. Work in confined spaces shall be avoided.

The area around the workspace shall be sectioned off. Ensure that the conditions within the area have been made safe by control of flammable material.

16.4.5 Checking for presence of refrigerant

The area shall be checked with an appropriate refrigerant detector prior to and during work, to ensure the technician is aware of potentially toxic or flammable atmospheres. Ensure that the leak detection equipment being used is suitable for use with all applicable refrigerants, i.e. non-sparking, adequately sealed or intrinsically safe.

16.4.6 Presence of fire extinguisher

If any hot work is to be conducted on the refrigerating equipment or any associated parts, appropriate fire extinguishing equipment shall be available to hand. Have a dry powder or CO₂ fire extinguisher adjacent to the charging area.

16.4.7 No ignition sources

No person carrying out work in relation to a refrigerating system which involves exposing any pipe work shall use any sources of ignition in such a manner that it can lead to the risk of fire or explosion. All possible ignition sources, including cigarette smoking, should be kept sufficiently far away from the site of installation, repairing, removing and disposal, during which refrigerant can possibly be released to the surrounding space. Prior to work taking place, the area around the equipment is to be surveyed to make sure that there are no flammable hazards or ignition risks. "No Smoking" signs shall be displayed.

16.4.8 Ventilated area

Ensure that the area is in the open or that it is adequately ventilated before breaking into the system or conducting any hot work. A degree of ventilation shall continue during the period that the work is carried out. The ventilation should safely disperse any released refrigerant and preferably expel it externally into the atmosphere.

16.4.9 Checks to the refrigerating equipment

Where electrical components are being changed, they shall be fit for the purpose and to the correct specification. At all times the manufacturer's maintenance and service guidelines shall be followed. If in doubt, consult the manufacturer's technical department for assistance.

The following checks shall be applied to installations using flammable refrigerants:

- the refrigerant charge is in accordance with the room size within which the refrigerant containing parts are installed;
- the ventilation machinery and outlets are operating adequately and are not obstructed;
- if an indirect refrigerating circuit is being used, the secondary circuit shall be checked for the presence of refrigerant;
- marking to the equipment continues to be visible and legible. Markings and signs that are illegible shall be corrected;
- refrigerating pipe or components are installed in a position where they are unlikely to be exposed to any substance which can corrode refrigerant containing components, unless the components are constructed of materials which are inherently resistant to being corroded or are suitably protected against being so corroded.

16.4.10 Checks to electrical devices

Repair and maintenance to electrical components shall include initial safety checks and component inspection procedures. If a fault exists that could compromise safety, then no electrical supply shall be connected to the circuit until it is satisfactorily dealt with. If the fault cannot be corrected immediately but it is necessary to continue operation, an adequate temporary solution shall be used. This shall be reported to the owner of the equipment so all parties are advised.

Initial safety checks shall include:

- that capacitors are discharged: this shall be done in a safe manner to avoid possibility of sparking;
- that no live electrical components and wiring are exposed while charging, recovering or purging the system;
- that there is continuity of earth bonding.

16.5 Sealed electrical components

WARNING

Sealed electrical components shall not be repaired.

16.6 Cabling

Check that cabling will not be subject to wear, corrosion, excessive pressure, vibration, sharp edges or any other adverse environmental effects. The check shall also take into account the effects of aging or continual vibration from sources such as compressors or fans.

16.7 Detection of flammable refrigerants

Under no circumstances shall potential sources of ignition be used in the searching for or detection of refrigerant leaks. A halide torch (or any other detector using a naked flame) shall not be used.

The following leak detection methods are deemed acceptable for all refrigerant systems.

Electronic leak detectors may be used to detect refrigerant leaks but, in the case of flammable refrigerants, the sensitivity can be inadequate, or can need re-calibration. (Detection equipment shall be calibrated in a refrigerant-free area.) Ensure that the detector is not a potential source of ignition and is suitable for the refrigerant used. Leak detection equipment shall be set at a percentage of the LFL of the refrigerant and shall be calibrated to the refrigerant employed, and the appropriate percentage of gas (25 % maximum) is confirmed.

Leak detection fluids are also suitable for use with most refrigerants but the use of detergents containing chlorine shall be avoided as the chlorine can react with the refrigerant and corrode the copper pipe-work.

NOTE Examples of leak detection methods are

- bubble method,
- fluorescent agent method.

If a leak is suspected, all naked flames shall be removed/extinguished.

If a leakage of refrigerant is found which requires brazing, all of the refrigerant shall be recovered from the system, or isolated (by means of shut-off valves) in a part of the system remote from the leak. Removal of refrigerant shall be according to Clause 16.8.

CAUTION

Oxygen free nitrogen (OFN) shall then be purged through the system both before and during the brazing process.

16.8 Refrigerant removal and circuit evacuation

When breaking into the refrigerant circuit to make repairs – or for any other purpose – conventional procedures shall be used. However, for flammable refrigerants it is important that best practice is followed since flammability is a consideration. The following procedure shall be adhered to:

- safely remove refrigerant following local and national regulations;
- evacuate;
- purge the circuit with inert gas (optional for A2L);
- evacuate (optional for A2L);
- continuously flush with inert gas when using flame to open circuit;
- open the circuit.

The refrigerant charge shall be recovered into the correct recovery cylinders.

CAUTION

An inert gas, specifically, is dry oxygen free nitrogen(OFN).
The system shall be “flushed” with OFN to render the unit safe. This process may need to be repeated several times.

Compressed air or oxygen shall not be used for purging refrigerant systems.

Purging of the refrigerant circuit shall be achieved by breaking the vacuum in the system with inert gas and continuing to fill until the working pressure is achieved, then venting to atmosphere, and finally pulling down to a vacuum. This process shall be repeated until no refrigerant is within the system. The system shall be vented down to atmospheric pressure to enable work to take place.

CAUTION

This operation is absolutely vital if brazing operations on the pipework are to take place.

Ensure that the outlet of the vacuum pump is not close to any potential ignition sources and that ventilation is available.

16.9 Charging procedures

In addition to conventional charging procedures, the following requirements shall be followed.

- Ensure that contamination of different refrigerants does not occur when using charging equipment. Hoses or lines shall be as short as possible to minimise the amount of refrigerant contained in them.
- Cylinders shall be kept in an appropriate position according to the instructions.
- Ensure that the refrigerating system is earthed prior to charging the system with refrigerant.
- Label the system when charging is complete (if not already labelled).
- Extreme care shall be taken not to overfill the refrigerating system.

Prior to recharging the system, it shall be pressure-tested with the appropriate purging gas. The system shall be leak-tested on completion of charging but prior to commissioning. A follow up leak test shall be carried out prior to leaving the site.

16.10 Decommissioning

Before carrying out this procedure, it is essential that the technician is completely familiar with the equipment and all its detail. It is recommended good practice that all refrigerants are recovered safely. Prior to the task being carried out, an oil and refrigerant sample shall be taken

in case analysis is required prior to re-use of recovered refrigerant. It is essential that electrical power is available before the task is commenced.

- 1) Become familiar with the equipment and its operation.
- 2) Isolate system electrically.
- 3) Before attempting the procedure, ensure that:
 - a) mechanical handling equipment is available, if required, for handling refrigerant cylinders;
 - b) all personal protective equipment is available and being used correctly;
 - c) the recovery process is supervised at all times by a competent person;
 - d) recovery equipment and cylinders conform to the appropriate standards.
- 4) Pump down refrigerant system, if possible.
- 5) If a vacuum is not possible, make a manifold so that refrigerant can be removed from various parts of the system.
- 6) Make sure that the cylinder is situated on the scales before recovery takes place.
- 7) Start the recovery machine and operate in accordance with instructions.
- 8) Do not overfill cylinders (no more than 80 % volume liquid charge).
- 9) Do not exceed the maximum working pressure of the cylinder, even temporarily.
- 10) When the cylinders have been filled correctly and the process completed, make sure that the cylinders and the equipment are removed from site promptly and all isolation valves on the equipment are closed off.
- 11) Recovered refrigerant shall not be charged into another refrigerating system unless it has been cleaned and checked.

16.11 Labelling

Equipment shall be labelled stating that it has been de-commissioned and emptied of refrigerant. The label shall be dated and signed. For appliances containing flammable refrigerants, ensure that there are labels on the equipment stating the equipment contains flammable refrigerant.

16.12 Recovery

When removing refrigerant from a system, either for servicing or decommissioning, it is required to follow good practice so that all refrigerants are removed safely.

When transferring refrigerant into cylinders, ensure that only appropriate refrigerant recovery cylinders are employed. Ensure that the correct number of cylinders for holding the total system charge is available. All cylinders to be used are designated for the recovered refrigerant and labelled for that refrigerant (i.e. special cylinders for the recovery of refrigerant). Cylinders shall be complete with pressure-relief valve and associated shut-off valves in good working order. Empty recovery cylinders are evacuated and, if possible, cooled before recovery occurs.

The recovery equipment shall be in good working order with a set of instructions concerning the equipment that is at hand and shall be suitable for the recovery of the flammable refrigerant. Consult manufacturer if in doubt. In addition, a set of calibrated weighing scales shall be available and in good working order. Hoses shall be complete with leak-free disconnect couplings and in good condition.

The recovered refrigerant shall be processed according to local legislation in the correct recovery cylinder, and the relevant waste transfer note arranged. Do not mix refrigerants in recovery units and especially not in cylinders.

If compressors or compressor oils are to be removed, ensure that they have been evacuated to an acceptable level to make certain that flammable refrigerant does not remain within the lubricant. The compressor body shall not be heated by an open flame or other ignition sources to accelerate this process. Draining of oil from a system shall be carried out safely.

ANNEX A: REFRIGERANT CYCLE

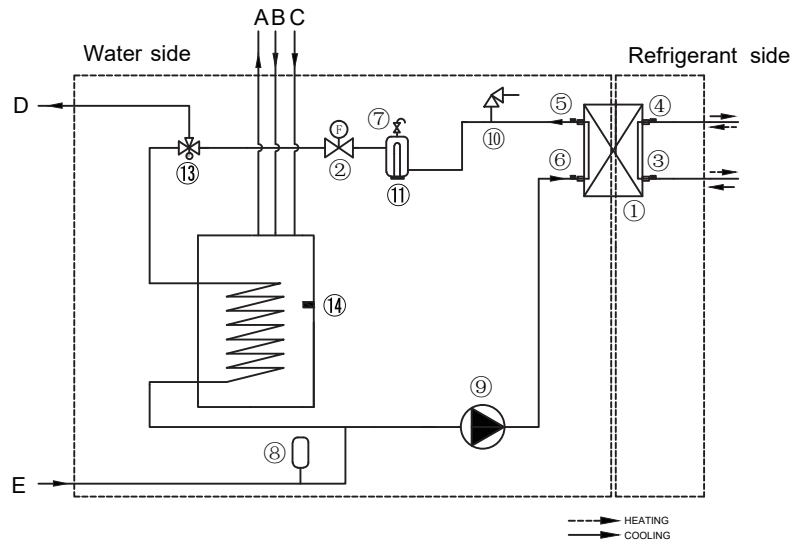

Standard Unit

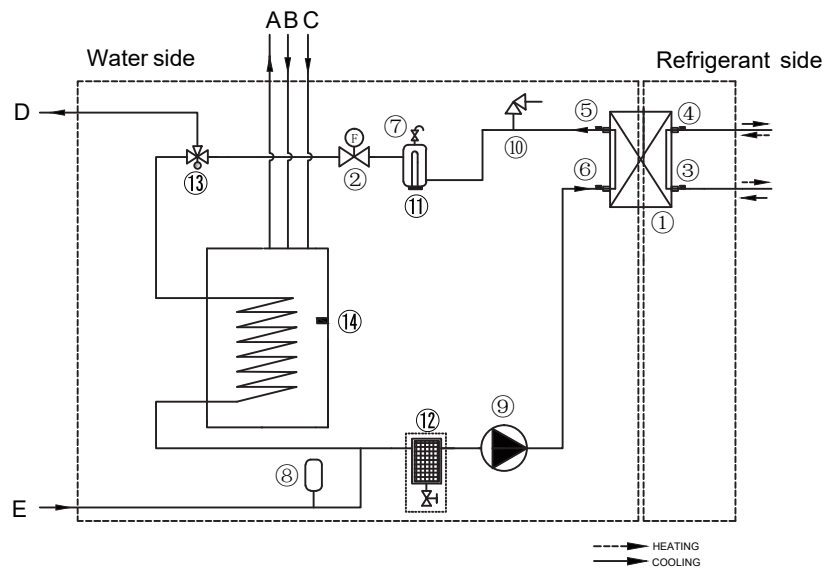

Optional Unit

Item	Description	Item	Description
1	Water side heat exchanger (Plate heat exchange)	11	Backup heater
2	Flow switch	12	Magnetic separator (Optional)
3	Refrigerant liquid piping temperature sensor	13	3-Way valve
4	Refrigerant gas piping temperature sensor	14	Domestic water tank temperature sensor
5	Water outlet temperature sensor	A	Domestic hot water outlet
6	Water inlet temperature sensor	B	Domestic hot water recirculation inlet
7	Automatic air purge valve	C	Domestic cold water inlet
8	Expansion vessel	D	Space heating/cooling water outlet
9	Circulated pump	E	Space heating/cooling water inlet
10	Pressure relief valve		

16110600A11357 V.A

此页不做菲林，仅核对使用

印刷技术要求

材质	封面封底105g铜版纸，内页双胶纸80g
规格	210*297mm(双面)
颜色	黑白
其他	胶装

设计更改记录表（仅做说明用，不做菲林）

版本升级	更改人	更改日期	更改主要内容	涉及更改页面 (印刷页码)