

Service Manual

RZAG35/50/60A Mini Sky-Air

Indoor unit

FDXM-F9 FFA-A9 FBA-A9 FCAG-B
FNA-A9 FTXM-M FHA-A9

Outdoor unit

RZAG35/50/60A



The present publication is drawn up by way of information only and does not constitute an offer binding upon Daikin Europe N.V.. Daikin Europe N.V. has compiled the content of this publication to the best of its knowledge. No express or implied warranty is given for the completeness, accuracy, reliability or fitness for particular purpose of its content and the products and services presented therein. Specifications are subject to change without prior notice. Daikin Europe N.V. explicitly rejects any liability for any direct or indirect damage, in the broadest sense, arising from or related to the use and/or interpretation of this publication. All content is copyrighted by Daikin Europe N.V..

Part 1. Introduction	7
1.1. Version log	7
1.2. Safety precautions	8
1.2.1. Meaning of symbols	8
1.2.2. Warnings	8
1.2.3. Cautions	10
1.2.4. Information	11
1.3. General operation	12
1.4. How to use	13
1.4.1. Interactive information flow	13
1.4.2. Parts of the book	14
1.4.2.1. The introduction chapter	14
1.4.2.2. The troubleshooting chapter	14
1.4.2.3. The repair chapter	14
1.4.2.4. The maintenance chapter	14
1.4.2.5. Appendices	14
1.4.3. Contact information	14
Part 2. Troubleshooting	15
2.1. Error codes check	15
2.1.1. Error codes via remote controller	15
2.1.1.1. General	15
2.1.1.2. How to clear error codes	15
2.1.1.3. History of error codes	16
2.1.2. Error codes via outdoor unit PCB	16
2.2. Error based troubleshooting	17
2.2.1. Indoor unit	18
2.2.1.1. "A0-00" – Detection of refrigerant leak (only for FNA-A9 model)	18
2.2.1.2. "A1-00" – PCB abnormality	18
2.2.1.3. "A1-01" – PCB abnormality	19
2.2.1.4. "A5-00" – Freeze-up protection / Heating peak cut control	19
2.2.1.5. "A6-00" – Fan motor abnormality	20
2.2.1.6. "C4-00" – Liquid pipe thermistor for heat exchanger abnormality	20
2.2.1.7. "C7-00" – Front panel open/close fault	21
2.2.1.8. "C9-00" – Suction air thermistor abnormality	21
2.2.1.9. "CH-00" – Abnormality of refrigerant leakage sensor (only for FNA-A9 model)	22
2.2.1.10. "UH-00" – Anti-icing function in other room(s)	22
2.2.2. Outdoor unit	23
2.2.2.1. "E1-00" – Outdoor unit PCB abnormality	23
2.2.2.2. "E3-00" – Discharge pressure abnormality	23
2.2.2.3. "E5-00" – Compressor motor lock or overheated	24
2.2.2.4. "E6-00" – Compressor motor lock	24
2.2.2.5. "E7-00" – Fan motor abnormality	25
2.2.2.6. "E8-00" – Compressor overcurrent detection	26
2.2.2.7. "EA-00" – 4-way valve abnormality	26
2.2.2.8. "F3-00" – Discharge pipe temperature abnormality	27
2.2.2.9. "F6-00" – High pressure abnormality or refrigerant overcharge	27
2.2.2.10. "H0-00" – Compressor sensor system abnormality	28
2.2.2.11. "H6-00" – Position detection sensor abnormality	28
2.2.2.12. "H8-00" – Compressor input (CT) system abnormality	29
2.2.2.13. "H9-00" – Outdoor air temperature thermistor abnormality	29
2.2.2.14. "J3-00" – Discharge pipe thermistor abnormality	30
2.2.2.15. "J5-00" – Suction pipe thermistor abnormality	30
2.2.2.16. "J6-00" – Outdoor heat exchanger thermistor abnormality	30
2.2.2.17. "J8-00" – Liquid pipe thermistor abnormality	31
2.2.2.18. "J9-00" – Gas pipe thermistor abnormality	31
2.2.2.19. "L1-00" – Outdoor main PCB abnormality	32

2.2.2.20. "L3-00" – Switch box temperature abnormality	33
2.2.2.21. "L4-00" – Inverter radiating fin temperature abnormality	33
2.2.2.22. "L5-00" – Inverter instantaneous overcurrent (AC output)	34
2.2.2.23. "P4-00" – Radiating fin temperature sensor abnormality	35
2.2.3. System	36
2.2.3.1. "U0-00" – Refrigerant shortage	36
2.2.3.2. "U2-00" – Power supply abnormality or instantaneous power failure	36
2.2.3.3. "U3-00" – Check operation not executed or transmission error	37
2.2.3.4. "U4-00" – Transmission abnormality between indoor unit and outdoor unit	38
2.2.3.5. "U5-00" – Malfunction of transmission between indoor unit and remote controller	38
2.2.3.6. "U7-00" – Transmission outdoor unit-outdoor unit abnormality	39
2.2.3.7. "UA-00" – Improper combination of indoor unit and outdoor unit	39
2.2.3.8. "UF-00" – Wiring and piping mismatch	40
2.2.4. Others	40
2.3. Symptom based troubleshooting	41
2.3.1. Indoor unit	41
2.3.2. Outdoor unit	41
2.3.3. System	41
2.3.4. Others	41
2.4. Component checklist	42
2.4.1. Indoor unit	43
2.4.1.1. Fan motor	43
2.4.2. Outdoor unit	44
2.4.2.1. 4-way valve	44
2.4.2.2. Compressor	46
2.4.2.3. Electronic expansion valve	48
2.4.2.4. Fan motor	50
2.4.2.5. Main PCB	50
2.4.2.6. Refrigerant thermistors	51
2.4.3. System	54
2.4.4. Others	54
2.5. Other capacity range	55

Part 3. Repair 57

3.1. Refrigerant repair procedures	57
3.1.1. Refrigerant piping handling	57
3.1.2. Recovery procedure	57
3.1.2.1. Outdoor unit casing	57
3.1.3. Refrigerant pump down	59
3.1.3.1. Small outdoor unit	59
3.1.3.2. Large outdoor unit	60
3.1.4. Piping repair procedures	60
3.2. Service tools	61
3.3. Unit specific repair procedures	62
3.3.1. Indoor unit	63
3.3.2. Outdoor unit	64
3.3.2.1. Basic removal	64
3.3.2.2. Replacing switch box	67
3.3.2.3. Replacing 4-way valve body	69
3.3.2.4. Replacing 4-way valve coil	71
3.3.2.5. Replacing compressor	72
3.3.2.6. Replacing DC fan motor assembly	75
3.3.2.7. Replacing expansion valve body	77
3.3.2.8. Replacing expansion valve motor	78
3.3.2.9. Replacing main PCB	80
3.3.2.10. Replacing propeller fan blade assembly	81
3.3.2.11. Replacing thermistors	82
3.3.2.12. Setting test mode for inverter checker	83

Part 4. Maintenance	85
4.1. Indoor unit	85
4.1.1. General maintenance	85
4.2. Outdoor unit	86
4.2.1. General maintenance outdoor unit	86
Part 5. Appendix	87
5.1. Field setting	89
5.1.1. Indoor unit	89
5.1.1.1. Indoor fan control during thermostat off in cooling	89
5.1.1.2. Brightness setting of multi-coloured lamp of the indoor unit	89
5.1.1.3. ON/OFF button on the indoor unit	89
5.1.1.4. Heat only mode	90
5.1.2. Outdoor unit	90
5.1.3. Remote controller	90
5.2. Detailed information setting mode	91
5.2.1. Indoor unit	91
5.2.2. Outdoor unit	91
5.2.3. Remote controller	91
5.3. Wiring diagram	92
5.3.1. Indoor unit	92
5.3.1.1. FDXM-F9	92
5.3.1.2. FFA-A9	92
5.3.1.3. FBA-A9	93
5.3.1.4. FCAG-B	93
5.3.1.5. FNA-A9	94
5.3.1.6. FTXM-M	95
5.3.1.7. FHA-A9	96
5.3.2. Outdoor unit	97
5.3.2.1. RZAG35/50/60A	97
5.3.3. Field wiring	97
5.4. Piping diagram	98
5.4.1. Indoor unit	98
5.4.2. Outdoor unit	98
5.4.2.1. RZAG35A	98
5.4.2.2. RZAG50/60A	99
5.5. Component overview of unit	100
5.5.1. Indoor unit	100
5.5.2. Outdoor unit	100
5.6. Product specific information	101
5.6.1. Error codes	101
5.6.1.1. "E7-00" – Fan motor abnormality	101
5.6.1.2. "EA-00" – Malfunction of 4-way valve	101
5.6.1.3. "F3-00" – Discharge pipe temperature abnormality	101
5.6.1.4. "L3-00" – Switch box temperature abnormality	101
5.6.1.5. "L4-00" – Inverter radiating fin temperature abnormality	101
5.6.2. Component checklist	101
5.7. Switch box	101
5.7.1. Indoor unit	101
5.7.2. Outdoor unit	101
5.8. Field information report	102

Figure 3-1: 1 service port at the stop valves	58
Figure 3-2: 3 service ports at the stop valves	59
Figure 3-3: Removing refrigerant connection cover	64
Figure 3-4: Removing the top plate	65
Figure 3-5: Removing the front plate	66
Figure 3-6: Removing the compressor sound insulation	66
Figure 3-7: Removing the switch box	68
Figure 3-8: Removing the 4-way valve	69
Figure 3-9: Removing the 4-way valve coil	71
Figure 3-10: Removing the compressor	73
Figure 3-11: Removing the DC fan motor assembly	76
Figure 3-12: Removing the expansion valve	77
Figure 3-13: Removing the expansion valve motor	78
Figure 3-14: Locking the expansion valve motor	79
Figure 3-15: Removing the main PCB	80
Figure 3-16: Removing the propeller fan blade assembly	81
Figure 3-17: Replacing a thermistor	82
Figure 5-1: How to change fan OFF to ON when in cooling thermo off	89
Figure 5-2: Heat only mode	90
Figure 5-3: Wiring diagram - indoor unit FDXM-F9	92
Figure 5-4: Wiring diagram - indoor unit FFA-A9	92
Figure 5-5: Wiring diagram - indoor unit FBA-A9	93
Figure 5-6: Wiring diagram - indoor unit FCAG-B	93
Figure 5-7: Wiring diagram - indoor unit FNA-A9	94
Figure 5-8: Wiring diagram - indoor unit FTXM-M	95
Figure 5-9: Wiring diagram - indoor unit FHA-A9	96
Figure 5-10: Wiring diagram - outdoor unit RZAG35/50/60A	97
Figure 5-11: Piping diagram - indoor unit	98
Figure 5-12: Piping diagram - outdoor unit RZAG35A	98
Figure 5-13: Piping diagram - outdoor unit RZAG50/60A	99
Figure 5-14: Component overview - outdoor unit	100

Part 1. Introduction

This part contains the following chapters:

Version log.....	7
Safety precautions.....	8
General operation.....	12
How to use	13

1.1. Version log

Version code	Description	Date
ESIE18-17	Document release	15/04/2019

1.2. Safety precautions

The precautions described in this document cover very important topics, follow them carefully.

All activities described in the service manual must be performed by an authorized person.

If you are not sure how to install, operate or service the unit, contact your dealer.









In accordance with the applicable legislation, it might be necessary to provide a logbook with the product containing at least: information on maintenance, repair work, results of tests, stand-by periods, ...

Also, at least, following information must be provided at an accessible place at the product:

- Instructions for shutting down the system in case of an emergency
- Name and address of fire department, police and hospital
- Name, address and day and night telephone numbers for obtaining service













In Europe, EN378 provides the necessary guidance for this logbook.





1.2.1. Meaning of symbols

	WARNING Indicates a situation that could result in death or serious injury.
	WARNING: RISK OF ELECTROCUTION Indicates a situation that could result in electrocution.
	WARNING: RISK OF BURNING Indicates a situation that could result in burning because of extreme hot or cold temperatures.
	WARNING: RISK OF EXPLOSION Indicates a situation that could result in explosion.
	WARNING: RISK OF POISONING Indicates a situation that could result in poisoning.
	WARNING: RISK OF FIRE Indicates a situation that could result in fire.
	CAUTION Indicates a situation that could result in equipment or property damage.
	INFORMATION Indicates useful tips or additional information.



1.2.2. Warnings

	WARNING Improper installation or attachment of equipment or accessories could result in electric shock, short-circuit, leaks, fire or other damage to the equipment. Only use accessories, optional equipment and spare parts made or approved by Daikin.
---	---

	<p>WARNING</p> <p>Make sure installation, testing and applied materials comply with applicable legislation (on top of the instructions described in the Daikin documentation).</p>
	<p>WARNING</p> <p>Make sure the work site environment is clean and safe to work in. Beware of spilled fluids, like water, oil or other substances. Protect bystanders from injury and property from possible damage cause by service works.</p>
	<p>WARNING</p> <p>Wear adequate personal protective equipment (protective gloves, safety glasses,...) when installing, maintaining or servicing the system.</p>
	<p>WARNING</p> <p>Tear apart and throw away plastic packaging bags so that nobody, especially children, can play with them. Possible risk: suffocation.</p>
	<p>WARNING</p> <p>Do NOT touch the air inlet or aluminium fins of the unit.</p>
	<p>WARNING</p> <ul style="list-style-type: none"> Do NOT place any objects or equipment on top of the unit. Do NOT sit, climb or stand on the unit.
	<p>WARNING</p> <p>During tests, NEVER pressurize the product with a pressure higher than the maximum allowable pressure (as indicated on the nameplate of the unit).</p>
	<p>WARNING</p> <ul style="list-style-type: none"> Never mix different refrigerants or allow air to enter the refrigerant system. Never charge recovered refrigerant from another unit. Use recovered refrigerant only on the same unit where it was recovered from, or have it recycled at a certified facility.
	<p>WARNING: RISK OF FIRE</p> <ul style="list-style-type: none"> When reconnecting a connector to the PCB, do not apply force or damage the connector or the connector pins on the PCB.
	<p>WARNING: RISK OF BURNING</p> <ul style="list-style-type: none"> Do NOT touch the refrigerant piping, water piping or internal parts during and immediately after operation. It could be too hot or too cold. Give it time to return to normal temperature. If you must touch it, wear protective gloves. Do NOT touch any accidental leaking refrigerant.
	<p>WARNING</p> <p>Always recover the refrigerants. Do NOT release them directly into the environment. Use a recovery pump to evacuate the installation.</p> <p>Take sufficient precautions in case of refrigerant leakage. If refrigerant gas leaks, ventilate the area immediately.</p> <p>Possible risks:</p> <ul style="list-style-type: none"> Excessive refrigerant concentrations in a closed room can lead to oxygen deficiency. Toxic gas may be produced if refrigerant gas comes into contact with fire. <p>Where applicable, pump down the system and close the service valve, before leaving the site if leak was not repaired, to avoid further leaking of the refrigerant.</p>
	<p>WARNING: RISK OF ELECTROCUTION</p> <ul style="list-style-type: none"> Turn OFF all power supply before removing the switch box cover, connecting electrical wiring or touching electrical parts. Where applicable, stop the equipment's operation first and allow (refrigerant) pressure to equalize, before turning OFF the power. Disconnect the power supply for more than 1 minute, and measure the voltage at the terminals of main circuit capacitors or electrical components before servicing. The voltage must be less than 50 V DC before you can touch electrical components. For the location of the terminals, refer to "Wiring diagram" on page 92. Do NOT touch electrical components with wet hands. Do NOT leave the unit unattended when the service cover is removed. Protect electric components from getting wet while the service cover is opened.

	<p>WARNING</p> <ul style="list-style-type: none"> • Only use copper wires. • All field wiring must be performed in accordance with the wiring diagram and installation manual supplied with the product. • If the power cable and lead wires have scratches or deteriorated, be sure to replace them. Damaged cable and wires may cause an electrical shock, excessive heat generation or fire. • Secure all terminal connections and provide proper routing for cables, both inside and outside the switchbox. • NEVER squeeze bundled cables and make sure they do not come in contact with the piping and sharp edges. • Make sure no external pressure is applied to the terminal connections. • Make sure to check the earth wiring. Do NOT earth the unit to a utility pipe, surge absorber, or telephone earth. Improper earth wiring may cause electrical shock. • Make sure to use a dedicated power circuit. NEVER use a power supply shared by another appliance. • Make sure to check the required fuses and/or circuit breakers before starting works.
	<p>WARNING</p> <ul style="list-style-type: none"> • After finishing the electrical work, confirm that each electrical component and terminal inside the electrical components box is connected securely. • Make sure all covers are closed before starting the unit again.
	<p>WARNING</p> <ul style="list-style-type: none"> • The area shall be checked with an appropriate refrigerant detector prior to and during work, to ensure the technician is aware of potentially toxic or flammable atmospheres. • Ensure that the leak detection equipment being used is suitable for use with all applicable refrigerants, i.e. non-sparking, adequately sealed or intrinsically safe.
	<p>WARNING</p> <ul style="list-style-type: none"> • Equipment shall be labelled stating that it has been de-commissioned and emptied of refrigerant. • The label shall be dated and signed. • For appliances containing flammable refrigerants, ensure that there are labels on the equipment stating the equipment contains flammable refrigerant.

1.2.3. Cautions

	<p>CAUTION</p> <p>Provide adequate measures to prevent that the unit can be used as a shelter by small animals. Small animals that make contact with electrical parts can cause malfunctions, smoke or fire.</p>
	<p>CAUTION</p> <ul style="list-style-type: none"> • Make sure water quality complies with EU directive 98/83 EC. • Check the system for leaks after each repair/modification of the water side. • Check drainage system(s) after repairs. • Be careful when tilting units as water may leak.

1.2.4. Information

**INFORMATION**

Make sure refrigerant piping installation complies with applicable legislation. In Europe, EN378 is the applicable standard.

**INFORMATION**

Make sure the field piping and connections are not subjected to stress.

1.3. General operation

- These split units are used for comfort cooling and are equipped with an inverter.
- The rotation speed rps (= rotation per second) of the inverter driven compressor, modulated by the inverter, can be varied according to the required capacity in the room.
- The compressor capacity step is changed in order to reach target compression ratio. The target compression ratio is calculated from deviation between actual and target condensation and evaporation temperature.
- Tc (condensing temperature) is used in heating mode.
- Te (evaporation temperature) is used if any indoor unit operates in cooling mode.
- The evaporating temperature in the heat exchanger is controlled by the electronic expansion valve.
- When indoor unit is selecting heating mode, discharge gas is supplied by the outdoor unit to the indoor unit.
- When indoor unit is selecting cooling mode, liquid refrigerant is supplied by the outdoor unit to the indoor unit.

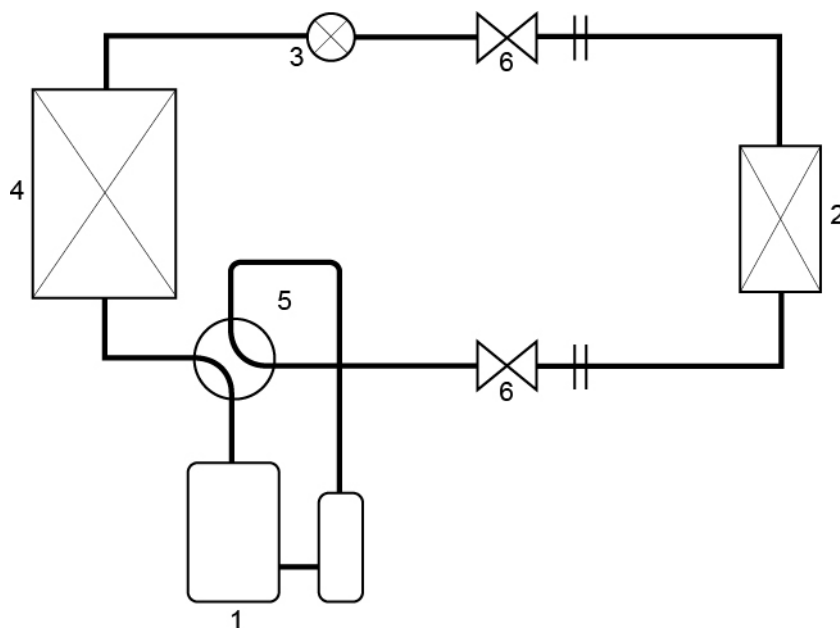

1. Compressor

2. Indoor heat exchanger

3. Expansion valve

4. Outdoor heat exchanger

5. 4-way valve

6. Stop valves

1.4. How to use

1.4.1. Interactive information flow

This Daikin product Service Manual is intended for professional use only. The actions described hereafter, are only to be performed by qualified and certified persons, taking into account the safety precautions mentioned in this manual and the local regulations as well.

By following the diagram below, the reader can find the relevant information related to his/her task. The digital (pdf) version of this book allows direct page access through all active links. When Adobe Acrobat Reader is used, the <Alt> + <Back Arrow> keys or the arrow in the top right-hand corner of this page can be used to return to the previously viewed page.

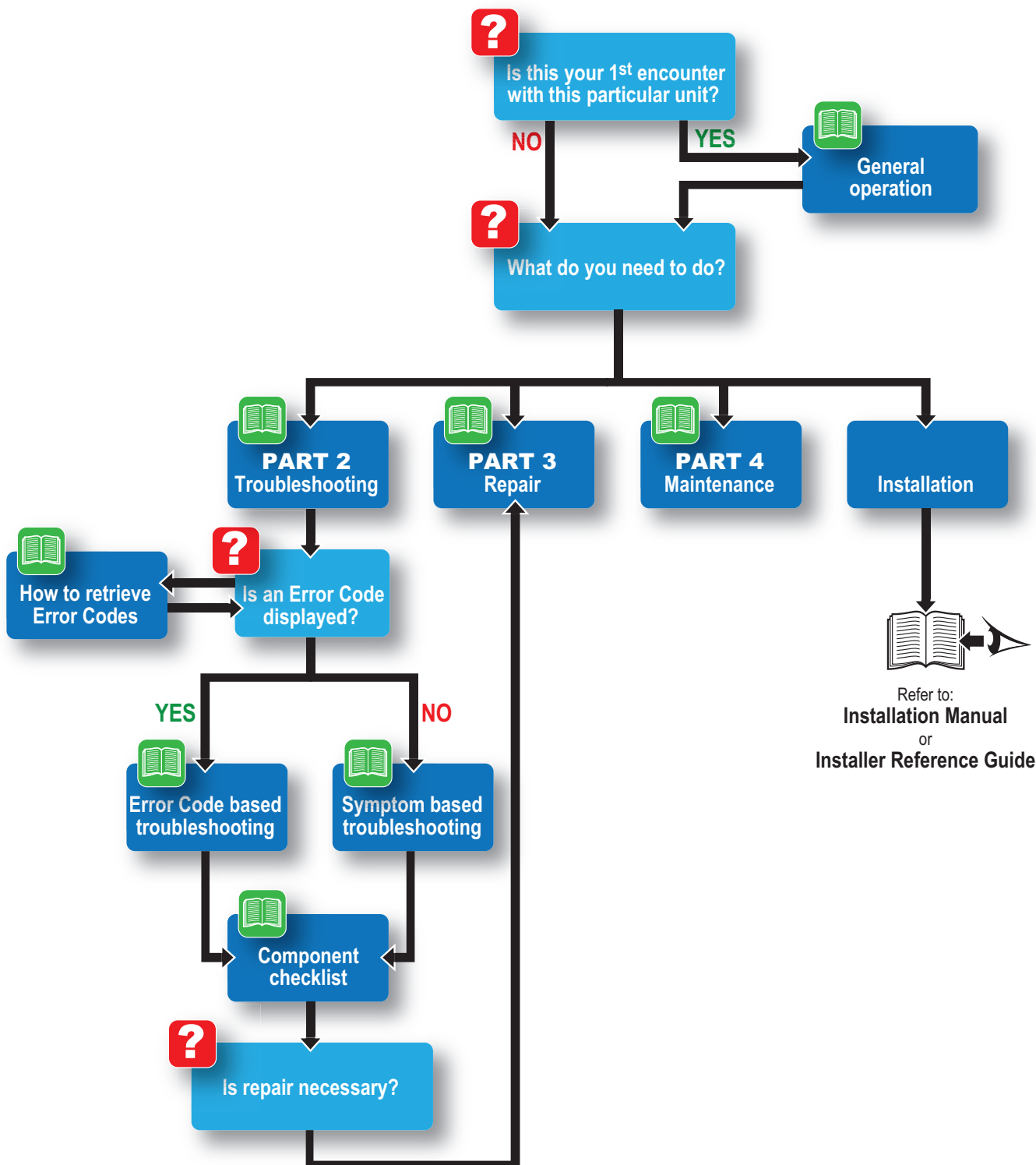

1.4.2. Parts of the book

This Daikin product Service Manual is intended for professional use only. The actions described hereafter, are only to be performed by qualified and certified persons, taking into account the safety precautions mentioned in this manual and the local regulations as well.

As can be observed from the Table of Contents, this manual is split up into several chapters:

1.4.2.1. The introduction chapter

The chapter "[Introduction](#)" on [page 7](#) includes the safety precautions, this topic and the general operation description of the product(s) this manual refers to.

1.4.2.2. The troubleshooting chapter

The chapter "[Troubleshooting](#)" on [page 15](#) not only deals with the methods to recognize and resolve occurring error codes; it also describes the methods how to solve a problem that does not immediately trigger an error code. Such problems are referred to as 'symptom based'. Both the error code based and symptom based troubleshooting tables, indicate possible causes, the necessary checks and in case required, how to repair. The possible causes have been sorted to probability of occurrence and speed of execution.

1.4.2.3. The repair chapter

The chapter "[Repair](#)" on [page 57](#) handles the removal and replacement of the major components in the product and discusses cleaning methods as well if applicable, such as for filters. Where applicable, refrigerant handling precautions are mentioned for certain actions; please consider these carefully for your own safety.

1.4.2.4. The maintenance chapter

The chapter "[Maintenance](#)" on [page 85](#) of this manual describes the maintenance intervals and procedures to be performed on the product. Remember that a well maintained product, is a more reliable and efficient product.

1.4.2.5. Appendices

Finally, the service manual provides in chapter "[Appendix](#)" on [page 87](#) valuable reference data such as piping/wiring diagrams, field settings overview and a checklist to be filled in when you need to escalate an issue to your dealer.

1.4.3. Contact information

This manual has been made with much care and effort. Use it in your daily jobs, as it has been made for you.

Despite our efforts, there is always a chance some cleric or other mistake has been made during the creation of this manual. We kindly ask you to send the found mistakes, or remarks for improvement, to the no-reply email address servicemanual@daikineurope.com.

Part 2. Troubleshooting

This part contains the following chapters:

Error codes check	15
Error based troubleshooting	17
Symptom based troubleshooting	41
Component checklist	42
Other capacity range	55

2.1. Error codes check

2.1.1. Error codes via remote controller

2.1.1.1. General

If operation stops due to malfunction, the remote controller's operation LED blinks, and malfunction code is displayed. (Even if stop operation is carried out, malfunction contents are displayed when inspection mode is entered.) The malfunction code enables you to tell what kind of malfunction caused operation to stop.

2.1.1.2. How to clear error codes

1. Replace sensor to new one.
2. Power ON the unit.
3. Clear last error:
 - Press "TEMP" and "MODE" buttons at the same time.

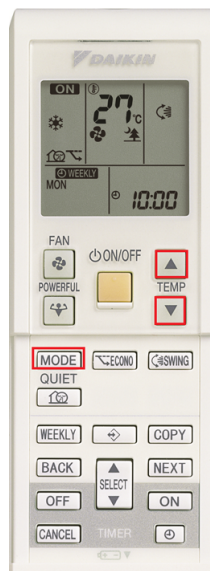

- Press "ON/OFF" button for 5 sec.

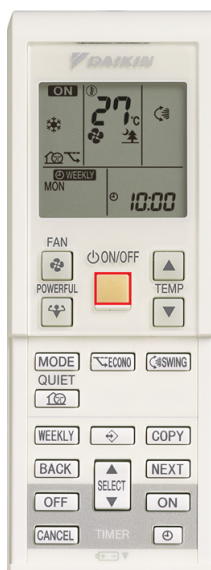

4. Power OFF and power ON the unit.
5. Go to "trial operation" (as explain in the manual):
 - Press "TEMP" and "MODE" buttons at the same time.

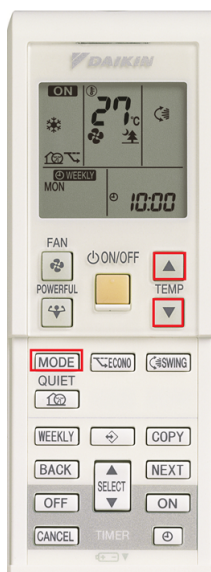

- Press "MODE" button 2 times and you will see 7 on the screen of the remote.

6. Power OFF and power ON the unit.
7. Normal unit operation.

2.1.1.3. History of error codes

Not applicable for this remote controller.

2.1.2. Error codes via outdoor unit PCB

Not applicable.

2.2. Error based troubleshooting

Overview of error codes:

Indoor unit	18
“A0-00” – Detection of refrigerant leak (only for FNA-A9 model)	18
“A1-00” – PCB abnormality	18
“A1-01” – PCB abnormality	19
“A5-00” – Freeze-up protection / Heating peak cut control	19
“A6-00” – Fan motor abnormality	20
“C4-00” – Liquid pipe thermistor for heat exchanger abnormality	20
“C7-00” – Front panel open/close fault.....	21
“C9-00” – Suction air thermistor abnormality.....	21
“CH-00” – Abnormality of refrigerant leakage sensor (only for FNA-A9 model)	22
“UH-00” – Anti-icing function in other room(s)	22
Outdoor unit.....	23
“E1-00” – Outdoor unit PCB abnormality.....	23
“E3-00” – Discharge pressure abnormality.....	23
“E5-00” – Compressor motor lock or overheated	24
“E6-00” – Compressor motor lock	24
“E7-00” – Fan motor abnormality	25
“E8-00” – Compressor overcurrent detection	26
“EA-00” – 4-way valve abnormality	26
“F3-00” – Discharge pipe temperature abnormality.....	27
“F6-00” – High pressure abnormality or refrigerant overcharge	27
“H0-00” – Compressor sensor system abnormality.....	28
“H6-00” – Position detection sensor abnormality	28
“H8-00” – Compressor input (CT) system abnormality.....	29
“H9-00” – Outdoor air temperature thermistor abnormality	29
“J3-00” – Discharge pipe thermistor abnormality	30
“J5-00” – Suction pipe thermistor abnormality.....	30
“J6-00” – Outdoor heat exchanger thermistor abnormality.....	30
“J8-00” – Liquid pipe thermistor abnormality	31
“J9-00” – Gas pipe thermistor abnormality	31
“L1-00” – Outdoor main PCB abnormality	32
“L3-00” – Switch box temperature abnormality	33
“L4-00” – Inverter radiating fin temperature abnormality	33
“L5-00” – Inverter instantaneous overcurrent (AC output).....	34
“P4-00” – Radiating fin temperature sensor abnormality.....	35
System	36
“U0-00” – Refrigerant shortage	36
“U2-00” – Power supply abnormality or instantaneous power failure.....	36
“U3-00” – Check operation not executed or transmission error	37
“U4-00” – Transmission abnormality between indoor unit and outdoor unit.....	38
“U5-00” – Malfunction of transmission between indoor unit and remote controller	38
“U7-00” – Transmission outdoor unit-outdoor unit abnormality	39
“UA-00” – Improper combination of indoor unit and outdoor unit	39
“UF-00” – Wiring and piping mismatch.....	40
Others	40

2.2.1. Indoor unit

2.2.1.1. "A0-00" – Detection of refrigerant leak (only for FNA-A9 model)

Trigger	Effect	Reset										
Detect gas leakage (R32 or other gases).	Outdoor unit stops running. Indoor fan starts in fan only. Blinking led indoor.	<p>After 10 min. of no gas detection:</p> <ul style="list-style-type: none"> A0 error disappears (auto reset) Unit starts working again <p>After 10 min. of gas detection:</p> <ul style="list-style-type: none"> A0 error continuous Buzzer will start beeping Action: <ol style="list-style-type: none"> Replace the sensor Clear the error code <p>1. Replace leakage sensor. 2. Clear error code. → Change field setting 15(25)-14 "03" and wait 3 min. after changing setting.</p> <table border="1"> <thead> <tr> <th colspan="2">Field setting</th> <th>01</th> <th>02</th> <th>03</th> </tr> </thead> <tbody> <tr> <td>15(25)-14</td> <td>Reset leak counter</td> <td>Factory setting (for Japan)</td> <td>Factory setting (for EU)</td> <td>Reset</td> </tr> </tbody> </table> <p>3. Power supply reset. 4. Set back field setting. → Change field setting 15(25)-14 "02" and wait 3 min. after changing setting.</p>	Field setting		01	02	03	15(25)-14	Reset leak counter	Factory setting (for Japan)	Factory setting (for EU)	Reset
Field setting		01	02	03								
15(25)-14	Reset leak counter	Factory setting (for Japan)	Factory setting (for EU)	Reset								

Possible cause	Check	Corrective action
Refrigerant leakage.	Check for refrigerant leak indoor unit with electronic leak detector.	Repair leak and recharge refrigerant if required. Clear error code.
No refrigerant leakage.	Check possible other gasses: hairspray, alcohol, cleaning agent, ...	Ventilate the room.

More info:

Check procedures	Replacing procedures
"How to clear error codes" on page 15	

2.2.1.2. "A1-00" – PCB abnormality

Trigger	Effect	Reset
The system cannot set the internal settings	Unit will stop operating.	Power reset via outdoor unit.

Possible cause	Check	Corrective action
Wrong models interconnected	Check if unit combination is official. Refer to 'Combination database'.	Install compatible models.
Faulty wiring.	Check the connection of all terminals by disconnecting and reconnecting all terminals.	Replace wire harness/terminal when connection is not OK.

Possible cause	Check	Corrective action
Faulty or disturbance of the power supply (imbalance > 10%). Power drop. Short circuit.	Check if the power supply is conform with regulations. No fluctuations in frequency.	Adjust power supply when required. Power reset via outdoor unit.
Faulty indoor PCB.	Check if error still occurs after turning off power and turning it back on again. Check if the indoor PCB receives power. Check if the HAP LED is blinking in regular intervals. Check if the correct spare part is installed. Check the wiring to indoor PCB.	Adjust power to the indoor PCB. Replace indoor PCB when HAP LED is not blinking in regular intervals. Install correct spare part or update indoor PCB. Adjust wiring to indoor PCB when required.

2.2.1.3. "A1-01" – PCB abnormality

Trigger	Effect	Reset
The system cannot set the internal settings	Unit will stop operating.	Power reset via outdoor unit.

Possible cause	Check	Corrective action
Wrong models interconnected	Check if unit combination is official. Refer to 'Combination database'.	Install compatible models.
Faulty wiring.	Check the connection of all terminals by disconnecting and reconnecting all terminals.	Replace wire harness/terminal when connection is not OK.
Faulty or disturbance of the power supply (imbalance > 10%). Power drop. Short circuit.	Check if the power supply is conform with regulations. No fluctuations in frequency.	Adjust power supply when required. Power reset via outdoor unit.
Faulty indoor PCB.	Check if error still occurs after turning off power and turning it back on again. Check if the indoor PCB receives power. Check if the HAP LED is blinking in regular intervals. Check if the correct spare part is installed. Check the wiring to indoor PCB.	Adjust power to the indoor PCB. Replace indoor PCB when HAP LED is not blinking in regular intervals. Install correct spare part or update indoor PCB. Adjust wiring to indoor PCB when required.

2.2.1.4. "A5-00" – Freeze-up protection / Heating peak cut control

Trigger	Effect	Reset
<ul style="list-style-type: none"> during cooling operation, indoor heat exchanger temperature is below 0°C (freeze-up protection control). during heating operation, indoor heat exchanger is above 65°C (heating peak-cut control). 	Unit will stop operating.	Automatic reset when temperature is within range.

Possible cause	Check	Corrective action
Air short-circuit.	Check if the airflow around the unit is OK and there are no obstructions.	Remove obstruction.
Clogged air filter.	Check if the air filter is clogged.	Clean the air filter.
Dust accumulation on indoor heat exchanger.	Check if indoor heat exchanger is dirty/dusty.	Clean the indoor heat exchanger.
Faulty indoor heat exchanger thermistor.	Check indoor heat exchanger thermistor.	Replace indoor heat exchanger thermistor when required.

Possible cause	Check	Corrective action
Faulty indoor PCB.	Check if error still occurs after turning off power and turning it back on again. Check if the indoor PCB receives power. Check if the HAP LED is blinking in regular intervals. Check if the correct spare part is installed. Check the wiring to indoor PCB.	Adjust power to the indoor PCB. Replace indoor PCB when HAP LED is not blinking in regular intervals. Install correct spare part or update indoor PCB. Adjust wiring to indoor PCB when required.

2.2.1.5. "A6-00" – Fan motor abnormality

Trigger	Effect	Reset
The rotation speed of the fan motor is not detected while the output voltage to the fan is at its maximum.	Unit will stop operating.	Power reset via outdoor unit.

Possible cause	Check	Corrective action
Faulty indoor PCB.	Check if error still occurs after turning off power and turning it back on again. Check if the indoor PCB receives power. Check if the HAP LED is blinking in regular intervals. Check if the correct spare part is installed. Check the wiring to indoor PCB.	Adjust power to the indoor PCB. Replace indoor PCB when HAP LED is not blinking in regular intervals. Install correct spare part or update indoor PCB. Adjust wiring to indoor PCB when required.
Faulty indoor fan motor.	Check the fan motor. Check fan motor connections and wiring.	Replace fan motor when required. Adjust wiring when required.
Indoor fan motor locked.	Switch of the power. Turn fan manually.	Replace fan motor when the fan does not turn smoothly.

More info:

Check procedures	Replacing procedures
"Fan motor" on page 43	

2.2.1.6. "C4-00" – Liquid pipe thermistor for heat exchanger abnormality

Trigger	Effect	Reset
Thermistor input is > 4.96 V or < 0.04 V during compressor operation.	Unit will stop operating.	Power reset via outdoor unit.

Possible cause	Check	Corrective action
Faulty liquid pipe thermistor.	Check liquid pipe thermistor.	Replace liquid pipe thermistor when required.
Faulty indoor unit main PCB.	Check if error still occurs after turning off power and turning it back on again. Check if the indoor PCB receives power. Check if the HAP LED is blinking in regular intervals. Check if the correct spare part is installed. Check the wiring to indoor PCB.	Adjust the power to the indoor main PCB. Replace indoor main PCB when HAP LED is not blinking in regular intervals.

More info:

Check procedures	Replacing procedures
"Refrigerant thermistors" on page 51	

2.2.1.7. "C7-00" – Front panel open/close fault

Trigger	Effect	Reset
Shutter limit switch not activated or faulty.	Unit will stop operating when error occurs 2 times.	Power reset via outdoor unit.

Possible cause	Check	Corrective action
Foreign substance in the blow port.	Check blow port for foreign material.	Remove foreign material when required.
Faulty shutter limit switch.	Check the limit switch continuity.	Replace the limit switch when continuity is not good.
Faulty wire harness.	Check the wire harness wiring. Check the wire harness connection.	Reconnect wire harness when required. Perform a power reset, if shutter valve does not close after power reset, replace wire harness.
Faulty shutter motor.	Check if motor operates after opening the shutter and power reset.	Replace indoor unit main PCB when required.
Faulty shutter sealing.	Check if shutter goes back open automatically after closing.	Replace sealing material when required.
Shutter is deformed.	Check if the error is still active after closing the shutter.	Replace shutter panel when required.

2.2.1.8. "C9-00" – Suction air thermistor abnormality

Trigger	Effect	Reset
Resistance value is out of range. T measured < -43.6°C or > 90°C.	Unit will stop operating.	Automatic reset when resistance is within range.

Possible cause	Check	Corrective action
Faulty suction air thermistor.	Check suction air thermistor.	Replace suction air thermistor when required.
Faulty indoor PCB.	Check if error still occurs after turning off power and turning it back on again. Check if the indoor PCB receives power. Check if the HAP LED is blinking in regular intervals. Check if the correct spare part is installed. Check the wiring to indoor PCB.	Adjust power to the indoor PCB. Replace indoor PCB when HAP LED is not blinking in regular intervals. Install correct spare part or update indoor PCB. Adjust wiring to indoor PCB when required.

More info:

Check procedures	Replacing procedures
"Refrigerant thermistors" on page 51	

2.2.1.9. "CH-00" – Abnormality of refrigerant leakage sensor (only for FNA-A9 model)

Trigger	Effect	Reset
Sensor error.	Unit will stop operating. Buzzer will beep.	See corrective action.

Possible cause	Check	Corrective action
Sensor error.	Check if connection and wiring of sensor to PCB is OK.	Correct the wiring connection or repair the wiring.
Broken sensor.	If all the wiring is OK but the error still exists then is the sensor not OK.	Replace sensor.

More info:

Check procedures	Replacing procedures
"How to clear error codes" on page 15	

2.2.1.10. "UH-00" – Anti-icing function in other room(s)

Trigger	Effect	Reset
A wrong connection is detected by checking the combination of the indoor and outdoor unit on the CPU	Operation halt due to freeze up prevention in other room/unspecified internal or external voltages/mismatch indoor and outdoor units	Auto reset after freeze up prevention is finished. Unit cannot restart before mismatch is removed.

Possible cause	Check	Corrective action
Freeze up prevention in other room.	Indoor fan is not operating while the error is displayed.	See error A5.
Mismatch of outdoor-indoor units.	Verify connection on combination data-base.	Replace indoor units when required.
Unspecified voltages.	Check supply voltage.	Adjust when required.

2.2.2. Outdoor unit

2.2.2.1. "E1-00" – Outdoor unit PCB abnormality

Trigger	Effect	Reset
Outdoor main PCB detects that EEPROM is abnormal.	Unit will stop operating.	Manual reset via user interface. Power reset via outdoor unit.

Possible cause	Check	Corrective action
Faulty outdoor unit main PCB.	Check if the HAP LED is blinking in regular intervals. Check if the correct spare part is installed. Check if the outdoor main PCB receives power.	Restore the power to the outdoor main PCB. Replace outdoor main PCB when HAP LED is not blinking in regular intervals.
Faulty capacity adapter on outdoor main PCB installed.	Check if the correct capacity adapter is used.	Replace capacity adapter when required.
External factor (e.g. electrical noise) (cause when error is reset after power reset, and error happens again after a while).	Check for source which could cause electrical interference.	Avoid electrical interference.
Faulty outdoor fan motor.	Check the fan motor. Check fan motor connections and wiring.	Replace fan motor when required. Adjust wiring when required.
Faulty or disturbance of the power supply (imbalance > 10%). Power drop. Short circuit.	Check if the power supply is conform with regulations. No fluctuations in frequency.	Adjust power supply when required. Power reset via outdoor unit.

2.2.2.2. "E3-00" – Discharge pressure abnormality

Trigger	Effect	Reset
Discharge pressure above 4.15 MPa.	Unit will stop operating.	Automatic reset when high pressure drops below 3.2 MPa.

Possible cause	Check	Corrective action
Stop valve is closed.	Check stop valve.	Open stop valve when required.
Blocked heat exchangers.	Are the heat exchangers clean?	Clean heat exchangers.
Insufficient airflow.	Are the fans operating?	Repair fan.
Non condensables in refrigerant.	Check for non condensables in refrigerant.	In case of suspicion of non condensables, recover, vacuum and recharge with virgin refrigerant.
Disconnected HPS wire harness terminal on the PCB.	Verify connection wire harness terminal on PCB.	Reconnect the terminal.
Disconnected HPS wire harness terminal on the HPS.	Verify connection wire harness terminal on HPS.	Reconnect the terminal(s).
Defective outdoor PCB.	Verify resistance of the wire harness terminal on the outdoor PCB.	If nearly 0 Ohm, replace outdoor PCB.
Broken high pressure sensor wire harness.	Verify resistance of the wire harness.	If resistance = infinity, replace wire harness.
Defective high pressure switch.	Check the resistance of the high pressure switch.	If resistance = infinity, replace high pressure switch.

2.2.2.3. “E5-00” – Compressor motor lock or overheated

Trigger	Effect	Reset
Compressor overload is detected.	Unit will stop operating.	Automatic reset if the unit runs for 60 seconds without error.

Possible cause	Check	Corrective action
Faulty discharge pipe thermistor.	Check discharge pipe thermistor.	Replace discharge pipe thermistor when required.
Faulty outdoor fan motor.	Check the fan motor. Check fan motor connections and wiring.	Replace fan motor when required. Adjust wiring when required.
Faulty overload protection.	Check the overload protection. Check the overload protection connections and wiring.	Replace the overload protection when required. Adjust wiring when required.
Faulty expansion valve.	Check the expansion valve.	Replace the expansion valve body or motor when required.
Faulty 4-way valve.	Check the 4-way valve.	Replace the 4-way valve coil or body when required.
Faulty outdoor unit main PCB.	Check if the HAP LED is blinking in regular intervals. Check if the correct spare part is installed. Check if the outdoor main PCB receives power.	Restore the power to the outdoor main PCB. Replace outdoor main PCB when HAP LED is not blinking in regular intervals.
Faulty power module = faulty outdoor inverter PCB.	Check outdoor inverter PCB. Check if the HAP LED is blinking in regular intervals. Check if the correct spare part is installed.	Restore the power to the outdoor inverter PCB. Replace the outdoor inverter PCB when required.
Refrigerant shortage.	Check for refrigerant shortage. Refer to the nameplate for the correct charge.	Charge the correct refrigerant amount when required.
Humidity in refrigerant (ice formation in expansion valve).	Check for humidity in the refrigerant.	In case of suspicion of humidity, recover, vacuum and recharge with virgin refrigerant.
Non condensables in refrigerant.	Check for non condensables in refrigerant.	In case of suspicion of non condensables, recover, vacuum and recharge with virgin refrigerant.
Stop valve is closed.	Check stop valve.	Open stop valve when required.

2.2.2.4. “E6-00” – Compressor motor lock

Trigger	Effect	Reset
The motor rotor does not rotate when the compressor is energized.	Unit will not stop operating.	Automatic reset after a continuous run for about 10 min.
	Unit will stop operating.	Manual reset via user interface.

Possible cause	Check	Corrective action
Faulty discharge thermistor.	Check the discharge thermistor.	Replace discharge thermistor when required.
Refrigerant shortage.	Check for refrigerant shortage. Refer to the nameplate for the correct charge.	Charge the correct refrigerant amount when required.
Humidity in refrigerant (ice formation in expansion valve).	Check for humidity in the refrigerant.	In case of suspicion of humidity, recover, vacuum and recharge with virgin refrigerant.

Possible cause	Check	Corrective action
Non condensables in refrigerant.	Check for non condensables in refrigerant.	In case of suspicion of non condensables, recover, vacuum and recharge with virgin refrigerant.
Stop valve is closed.	Check stop valve.	Open stop valve when required.
Refrigerant circuit is clogged (HP - LP > 0,26 MPa).	Check for possible blockage (blockages can be checked by measuring the refrigerant/pipe temperature. Sudden drop in temperature could indicate a blockage (remark: this is not valid for the expansion valve)).	Replace the blocked part.
Faulty compressor.	Check compressor. Check connections and wiring of the compressor. Check expansion valve (liquid back issue). Check the refrigerant charge. Refer to the nameplate for correct charge.	Replace compressor when required. Investigate reason of breakdown. Replace expansion valve when required. Fix possible leak.
Compressor turned off too fast.		Wait for guard timer.
Faulty outdoor unit main PCB.	Check if the HAP LED is blinking in regular intervals. Check if the correct spare part is installed. Check if the outdoor main PCB receives power.	Restore the power to the outdoor main PCB. Replace outdoor main PCB when HAP LED is not blinking in regular intervals.
Faulty outdoor inverter PCB.	Check outdoor inverter PCB. Check if the HAP LED is blinking in regular intervals. Check if the correct spare part is installed.	Restore the power to the outdoor inverter PCB. Replace the outdoor inverter PCB when required.
Faulty 4-way valve.	Check the 4-way valve.	Replace the 4-way valve coil or body when required.
Faulty expansion valve.	Check the expansion valve.	Replace the expansion valve body or motor when required.

2.2.2.5. "E7-00" – Fan motor abnormality

Trigger	Effect	Reset
Fan does not start in about 15~30 seconds = fan motor lock. It can occur that E7-00 error is triggered even when the fan motor is running caused by a faulty hall signal.	Unit will not stop operating.	Automatic reset after a continuous run.
	Unit will stop operating.	Manual reset via user interface.

Possible cause	Check	Corrective action
Faulty outdoor fan motor.	Check the fan motor. Check fan motor connections and wiring.	Replace fan motor when required. Adjust wiring when required.
Faulty outdoor inverter PCB.	Check outdoor inverter PCB. Check if the HAP LED is blinking in regular intervals. Check if the correct spare part is installed.	Restore the power to the outdoor inverter PCB. Replace the outdoor inverter PCB when required.
Blown fuse.	Check the fuse on the outdoor unit PCB's.	Replace fuse when required.

2.2.2.6. "E8-00" – Compressor overcurrent detection

Trigger	Effect	Reset
When the compressor is running the current exceeds 9.25 A ~ 20 A (depending on the unit) for 2.5 seconds.	Unit will stop operating.	Manual reset via user interface.

Possible cause	Check	Corrective action
Outdoor temperature is out of operation range.	Check the outdoor temperature.	Wait until the temperature is within operation range.
Faulty compressor.	Check compressor. Check connections and wiring of the compressor. Check expansion valve (liquid back issue). Check the refrigerant charge. Refer to the nameplate for correct charge.	Replace compressor when required. Investigate reason of breakdown. Replace expansion valve when required. Fix possible leak.
Faulty power module. = Faulty inverter PCB.	Check outdoor inverter PCB. Check if the HAP LED is blinking in regular intervals. Check if the correct spare part is installed.	Restore the power to the outdoor inverter PCB. Replace the outdoor inverter PCB when required.
Faulty or disturbance of the power supply (imbalance > 10%). Power drop. Short circuit.	Check if the power supply is conform with regulations. No fluctuations in frequency.	Adjust power supply when required. Power reset via outdoor unit.

2.2.2.7. "EA-00" – 4-way valve abnormality

Trigger	Effect	Reset
The room thermistor / indoor heat exchanger are not functioning within operation range.	Unit will not stop operating.	Automatic reset when unit runs without error for 60 minutes.
	Unit will stop operating.	Manual reset via user interface.

Possible cause	Check	Corrective action
Faulty 4-way valve coil.	Check 4-way valve coil.	Replace 4-way valve coil when required.
Faulty 4-way valve body, blocked.	Check 4-way valve body.	Replace 4-way valve body when required.
Faulty outdoor unit main PCB.	Check if the HAP LED is blinking in regular intervals. Check if the correct spare part is installed. Check if the outdoor main PCB receives power.	Restore the power to the outdoor main PCB. Replace outdoor main PCB when HAP LED is not blinking in regular intervals.
Faulty room thermistor.	Check room thermistor.	Replace room thermistor when required.
Faulty indoor heat exchanger thermistor.	Check indoor heat exchanger thermistor.	Replace indoor heat exchanger thermistor when required.
Refrigerant shortage.	Check for refrigerant shortage. Refer to the nameplate for the correct charge.	Charge the correct refrigerant amount when required.
Humidity in refrigerant (ice formation in expansion valve).	Check for humidity in the refrigerant.	In case of suspicion of humidity, recover, vacuum and recharge with virgin refrigerant.
Non condensables in refrigerant.	Check for non condensables in refrigerant.	In case of suspicion of non condensables, recover, vacuum and recharge with virgin refrigerant.
Stop valve is closed.	Check stop valve.	Open stop valve when required.
Faulty stop valve.	Check the stop valve.	Replace the stop valve when required.

Possible cause	Check	Corrective action
Wrong combination hybrid and outdoor unit.	Check if correct hybrid is installed.	Make official combination hybrid and outdoor unit.

2.2.2.8. "F3-00" – Discharge pipe temperature abnormality

Trigger	Effect	Reset
Discharge temperature is too high: <ul style="list-style-type: none"> If the discharge temperature detected is above A°C, 10 times within 200 min. If within 200 min the discharge temperature detected is 10 times above B°C for 15 min. 	Unit will not stop operating.	Automatic reset when temperature drops below C°C.
	Unit will stop operating.	Manual reset via remote controller.

Possible cause	Check	Corrective action
Refrigerant shortage.	Check for refrigerant shortage. Refer to the nameplate for the correct charge.	Charge the correct refrigerant amount when required.
Humidity in refrigerant (ice formation in expansion valve).	Check for humidity in the refrigerant.	In case of suspicion of humidity, recover, vacuum and recharge with virgin refrigerant.
Non condensables in refrigerant.	Check for non condensables in refrigerant.	In case of suspicion of non condensables, recover, vacuum and recharge with virgin refrigerant.
Stop valve is closed.	Check if stop valve is open.	Open stop valve when required.
Faulty 4-way valve.	Check the 4-way valve.	Replace the 4-way valve coil or body when required.
Faulty expansion valve.	Check the expansion valve.	Replace the expansion valve body or motor when required.
Faulty outdoor unit main PCB.	Check if the HAP LED is blinking in regular intervals. Check if the correct spare part is installed. Check if the outdoor main PCB receives power.	Restore the power to the outdoor main PCB. Replace outdoor main PCB when HAP LED is not blinking in regular intervals.
Faulty discharge thermistor.	Check discharge thermistor.	Replace discharge thermistor when required.
Faulty heat exchanger thermistor.	Check heat exchanger thermistor.	Replace heat exchanger thermistor when required.
Faulty outdoor temperature thermistor.	Check outdoor temperature thermistor.	Replace outdoor temperature thermistor when required.

2.2.2.9. "F6-00" – High pressure abnormality or refrigerant overcharge

Trigger	Effect	Reset
Outdoor heat exchanger thermistor measures temperature > 60°C~65°C (depending on model).	Unit will not stop operating.	Automatic reset when temperature drops below 50°C.

Possible cause	Check	Corrective action
Installation space is too small.	Check if the installation space is in line with regulations.	Adjust installation space.
Dirty outdoor heat exchanger.		Clean the outdoor heat exchanger.
Faulty outdoor fan motor.	Check the fan motor. Check fan motor connections and wiring.	Replace fan motor when required. Adjust wiring when required.

Possible cause	Check	Corrective action
Faulty stop valve.	Check the stop valve.	Replace the stop valve when required.
Faulty heat exchanger thermistor.	Check heat exchanger thermistor.	Replace heat exchanger thermistor when required.
Faulty expansion valve.	Check the expansion valve.	Replace the expansion valve body or motor when required.
Faulty outdoor unit main PCB.	Check if the HAP LED is blinking in regular intervals. Check if the correct spare part is installed. Check if the outdoor main PCB receives power.	Restore the power to the outdoor main PCB. Replace outdoor main PCB when HAP LED is not blinking in regular intervals.

2.2.2.10. "H0-00" – Compressor sensor system abnormality

Trigger	Effect	Reset
DC voltage before compressor start-up is out of range (0.5~4.5 V).	Unit will stop operating.	Manual reset via user interface.
DC voltage before compressor start-up is below 50 V.	Unit will stop operating.	Manual reset via user interface.

Possible cause	Check	Corrective action
Faulty outdoor unit main PCB.	Check if the HAP LED is blinking in regular intervals. Check if the correct spare part is installed. Check if the outdoor main PCB receives power.	Restore the power to the outdoor main PCB. Replace outdoor main PCB when HAP LED is not blinking in regular intervals.
Faulty outdoor inverter PCB.	Check outdoor inverter PCB. Check if the HAP LED is blinking in regular intervals. Check if the correct spare part is installed.	Restore the power to the outdoor inverter PCB. Replace the outdoor inverter PCB when required.
Faulty connection or wiring of the PCB's.	Check the connections and the wiring of the PCB's.	Adjust connection or wiring when required.
Faulty or disturbance of the power supply (imbalance > 10%). Power drop. Short circuit.	Check if the power supply is conform with regulations. No fluctuations in frequency.	Adjust power supply when required. Power reset via outdoor unit.

2.2.2.11. "H6-00" – Position detection sensor abnormality

Trigger	Effect	Reset
Compressor fails to start within 15 seconds after the compressor run command signal is sent.	Unit will not stop operating.	Automatic reset after a continuous run of 10 minutes.
	Unit will stop operating if the warning occurs 8 times.	Manual reset via remote controller.

Possible cause	Check	Corrective action
Faulty compressor.	Check compressor. Check connections and wiring of the compressor. Check expansion valve (liquid back issue). Check the refrigerant charge. Refer to the nameplate for correct charge.	Replace compressor when required. Investigate reason of breakdown. Replace expansion valve when required. Fix possible leak.

Possible cause	Check	Corrective action
Faulty outdoor unit main PCB.	Check if the HAP LED is blinking in regular intervals. Check if the correct spare part is installed. Check if the outdoor main PCB receives power.	Restore the power to the outdoor main PCB. Replace outdoor main PCB when HAP LED is not blinking in regular intervals.
Faulty outdoor inverter PCB.	Check outdoor inverter PCB. Check if the HAP LED is blinking in regular intervals. Check if the correct spare part is installed.	Restore the power to the outdoor inverter PCB. Replace the outdoor inverter PCB when required.
Stop valve is closed.	Check stop valve.	Open stop valve when required.
Faulty or disturbance of the power supply (imbalance > 10%). Power drop. Short circuit.	Check if the power supply is conform with regulations. No fluctuations in frequency.	Adjust power supply when required. Power reset via outdoor unit.

2.2.2.12. "H8-00" – Compressor input (CT) system abnormality

Trigger	Effect	Reset
DC voltage or DC current sensor abnormality based on the compressor running frequency and the input current.	Unit will not stop operating.	Automatic reset when compressor runs normally for 60 minutes.
	Unit will stop operating if the warning occurs several times.	Manual reset via user interface.

Possible cause	Check	Corrective action
Faulty outdoor unit main PCB.	Check if the HAP LED is blinking in regular intervals. Check if the correct spare part is installed. Check if the outdoor main PCB receives power.	Restore the power to the outdoor main PCB. Replace outdoor main PCB when HAP LED is not blinking in regular intervals.
Faulty power module. Input current or compressor current too low. Faulty outdoor inverter PCB.	Check outdoor inverter PCB. Check if the HAP LED is blinking in regular intervals. Check if the correct spare part is installed.	Restore the power to the outdoor inverter PCB. Replace the outdoor inverter PCB when required.
Faulty compressor.	Check compressor. Check connections and wiring of the compressor. Check expansion valve (liquid back issue). Check the refrigerant charge. Refer to the nameplate for correct charge.	Replace compressor when required. Investigate reason of breakdown. Replace expansion valve when required. Fix possible leak.
Faulty reactor.	Check reactor.	Replace reactor when required.

2.2.2.13. "H9-00" – Outdoor air temperature thermistor abnormality

Trigger	Effect	Reset
Thermistor input voltage is > 4.96 V or < 0.04 V when power is on.	Unit will stop operating.	Manual reset via user interface.

Possible cause	Check	Corrective action
Faulty outdoor air temperature thermistor.	Check outdoor temperature thermistor.	Replace outdoor temperature thermistor when required.

Possible cause	Check	Corrective action
Faulty outdoor unit main PCB.	Check if the HAP LED is blinking in regular intervals. Check if the correct spare part is installed. Check if the outdoor main PCB receives power.	Restore the power to the outdoor main PCB. Replace outdoor main PCB when HAP LED is not blinking in regular intervals.

2.2.2.14. “J3-00” – Discharge pipe thermistor abnormality

Trigger	Effect	Reset
Thermistor input voltage is > 4.96 V or < 0.04 V when power is on.	Unit will stop operating.	Manual reset via user interface.
Discharge pipe temperature is lower than the heat exchanger temperature.		

Possible cause	Check	Corrective action
Faulty discharge pipe thermistor.	Check discharge pipe thermistor.	Replace discharge pipe thermistor when required.
Faulty outdoor unit main PCB.	Check if the HAP LED is blinking in regular intervals. Check if the correct spare part is installed. Check if the outdoor main PCB receives power.	Restore the power to the outdoor main PCB. Replace outdoor main PCB when HAP LED is not blinking in regular intervals.

2.2.2.15. “J5-00” – Suction pipe thermistor abnormality

Trigger	Effect	Reset
Suction pipe thermistor detects an abnormal value (open or short circuit).	Unit will stop operating.	Automatic reset.

Possible cause	Check	Corrective action
Faulty outdoor unit main PCB.	Check if the HAP LED is blinking in regular intervals. Check if the correct spare part is installed. Check if the outdoor main PCB receives power.	Adjust the power to the outdoor main PCB. Replace outdoor main PCB when HAP LED is not blinking in regular intervals.
Faulty suction pipe thermistor.	Check suction pipe thermistor.	Replace suction pipe thermistor when required.
Faulty capacity adapter on outdoor PCB.	Check if the correct adapter is installed. Check if the correct spare part is installed.	Adjust capacity adapter when required.

2.2.2.16. “J6-00” – Outdoor heat exchanger thermistor abnormality

Trigger	Effect	Reset
Thermistor input voltage is > 4.96 V or < 0.04 V when power is on.	Unit will stop operating.	Manual reset via user interface.

Possible cause	Check	Corrective action
Faulty heat exchanger thermistor.	Check heat exchanger thermistor.	Replace heat exchanger thermistor when required.

Possible cause	Check	Corrective action
Faulty outdoor unit main PCB.	Check if the HAP LED is blinking in regular intervals. Check if the correct spare part is installed. Check if the outdoor main PCB receives power.	Restore the power to the outdoor main PCB. Replace outdoor main PCB when HAP LED is not blinking in regular intervals.

More info:

Check procedures	Replacing procedures
"Refrigerant thermistors" on page 51	"Replacing thermistors" on page 82
"Main PCB" on page 50	"Replacing main PCB" on page 80

2.2.2.17. "J8-00" – Liquid pipe thermistor abnormality

Trigger	Effect	Reset
Liquid pipe thermistor detects an abnormal value (open or short circuit).	Unit will stop operating.	Automatic reset.

Possible cause	Check	Corrective action
Faulty outdoor unit main PCB.	Check if the HAP LED is blinking in regular intervals. Check if the correct spare part is installed. Check if the outdoor main PCB receives power.	Adjust the power to the outdoor main PCB. Replace outdoor main PCB when HAP LED is not blinking in regular intervals.
Faulty liquid pipe thermistor.	Check liquid pipe thermistor.	Replace liquid pipe thermistor when required.
Faulty capacity adapter on outdoor PCB.	Check if the correct adapter is installed. Check if the correct spare part is installed.	Adjust capacity adapter when required.

More info:

Check procedures	Replacing procedures
"Main PCB" on page 50	"Replacing main PCB" on page 80
"Refrigerant thermistors" on page 51	"Replacing thermistors" on page 82

2.2.2.18. "J9-00" – Gas pipe thermistor abnormality

Trigger	Effect	Reset
Thermistor input voltage is > 4.96 V or < 0.04 V when power is on.	Unit will stop operating.	Manual reset via user interface.
Discharge pipe temperature is lower than the heat exchanger temperature.		

Possible cause	Check	Corrective action
Faulty discharge pipe thermistor.	Check discharge pipe thermistor.	Replace discharge pipe thermistor when required.
Faulty outdoor unit main PCB.	Check if the HAP LED is blinking in regular intervals. Check if the correct spare part is installed. Check if the outdoor main PCB receives power.	Restore the power to the outdoor main PCB. Replace outdoor main PCB when HAP LED is not blinking in regular intervals.

More info:

Check procedures	Replacing procedures
"Refrigerant thermistors" on page 51	"Replacing thermistors" on page 82
"Main PCB" on page 50	"Replacing main PCB" on page 80

2.2.2.19. "L1-00" – Outdoor main PCB abnormality

Trigger	Effect	Reset
Outdoor main PCB detects current/voltage errors.	Unit will stop operating.	Manual reset via user interface. Power reset via outdoor unit.

Possible cause	Check	Corrective action
Blown fuse.	Check fuse on outdoor main PCB.	Replace fuse if blown.
Faulty outdoor unit main PCB.	Check if the HAP LED is blinking in regular intervals. Check if the correct spare part is installed. Check if the outdoor main PCB receives power.	Adjust the power to the outdoor main PCB. Replace outdoor main PCB when HAP LED is not blinking in regular intervals.
Faulty outdoor inverter PCB.	Check outdoor inverter PCB. Check if the alive led is blinking in regular intervals. Check if the correct spare part is installed.	Adjust the power to the outdoor inverter PCB. Replace outdoor inverter PCB.
Faulty compressor.	Check compressor. Check connections and wiring of the compressor. Check expansion valve (liquid back issue). Check the refrigerant charge. Refer to the nameplate for correct charge.	Replace compressor when required. Investigate reason of breakdown. Replace expansion valve when required. Fix possible leak.
Faulty or disturbance of the power supply (imbalance > 10%). Power drop. Short circuit.	Check if the power supply is conform with regulations. No fluctuations in frequency.	Adjust power supply when required. Power reset via outdoor unit.
Faulty outdoor fan motor.	Check the fan motor. Check fan motor connections and wiring.	Replace fan motor when required. Adjust wiring when required.
Faulty capacity adapter on outdoor PCB.	Check if the correct adapter is installed. Check if the correct spare part is installed.	Adjust capacity adapter when required.
External factory (e.g. electrical noise). (cause when error is reset after power reset, and error happens again after a while).	Check for source which could cause electrical interference.	Avoid electrical interference.

More info:

Check procedures	Replacing procedures
"Main PCB" on page 50	"Replacing main PCB" on page 80
"Compressor" on page 46	"Replacing compressor" on page 72
"Electronic expansion valve" on page 48	"Replacing expansion valve body" on page 77
"Fan motor" on page 50	"Replacing DC fan motor assembly" on page 75

2.2.2.20. "L3-00" – Switch box temperature abnormality

Trigger	Effect	Reset
Switch box temperature is too high when the compressor is off.	Unit will not stop operating.	Automatic reset when temperature drops.
	Unit will stop operating.	Manual reset via remote controller.

Possible cause	Check	Corrective action
Faulty outdoor inverter PCB.	Check outdoor inverter PCB.	Restore the power to the outdoor inverter PCB.
Faulty radiation fin thermistor.	Check if the HAP LED is blinking in regular intervals. Check if the correct spare part is installed.	Replace the outdoor inverter PCB when required.
Faulty outdoor fan motor.	Check the fan motor. Check fan motor connections and wiring.	Replace fan motor when required. Adjust wiring when required.
Faulty or disturbance of the power supply (imbalance > 10%). Power drop. Short circuit.	Check if the power supply is conform with regulations. No fluctuations in frequency.	Adjust power supply when required. Power reset via outdoor unit.
Outdoor heat exchanger is dirty.	Check outdoor heat exchanger.	Clean outdoor heat exchanger when required.

More info:



INFORMATION

The Inverter PCB and Main PCB are 1 PCB in this unit.

Check procedures	Replacing procedures
"Main PCB" on page 50	"Replacing main PCB" on page 80
"Fan motor" on page 50	"Replacing DC fan motor assembly" on page 75
"L3-00" – Switch box temperature abnormality" on page 101	

2.2.2.21. "L4-00" – Inverter radiating fin temperature abnormality

Trigger	Effect	Reset
Radiation fin temperature rise is detected.	Unit will stop operating.	Automatic reset.
		Power reset via outdoor unit.

Possible cause	Check	Corrective action
Faulty outdoor fan motor.	Check the fan motor. Check fan motor connections and wiring.	Replace fan motor when required. Adjust wiring when required.
Faulty or disturbance of the power supply (imbalance > 10%). Power drop. Short circuit.	Check if the power supply is conform with regulations. No fluctuations in frequency.	Adjust power supply when required. Power reset via outdoor unit.
Faulty radiating fin thermistor.	Check radiating fin thermistor.	Replace radiating fin thermistor when required.
Faulty outdoor unit PCB in which radiating fin thermistor is connected.	Check if the HAP LED is blinking in regular intervals. Check if the correct spare part is installed. Check if the outdoor main PCB receives power.	Restore the power to the outdoor main PCB. Replace outdoor main PCB when HAP LED is not blinking in regular intervals.
Silicon grease is not applied properly on the radiation fin.	Check the silicon grease on the outdoor unit PCB.	Adjust silicon grease when required.

More info:

Check procedures	Replacing procedures
"Fan motor" on page 50	"Replacing DC fan motor assembly" on page 75
"Refrigerant thermistors" on page 51	"Replacing thermistors" on page 82
"Main PCB" on page 50	"Replacing main PCB" on page 80
""L4-00" – Inverter radiating fin temperature abnormality" on page 101	

2.2.2.22. "L5-00" – Inverter instantaneous overcurrent (AC output)

Trigger	Effect	Reset
An output overcurrent is detected by checking the current that flows in the inverter DC section.	Unit will stop operating.	Manual reset via user interface.

Possible cause	Check	Corrective action
Installation of the unit is not in line with specifications.	Check the installation specifications. Refer to the installation manual.	Adjust the installation when required.
Refrigerant shortage.	Check for refrigerant shortage. Refer to the nameplate for the correct charge.	Charge the correct refrigerant amount when required.
Humidity in refrigerant (ice formation in expansion valve).	Check for humidity in the refrigerant.	In case of suspicion of humidity, recover, vacuum and recharge with virgin refrigerant.
Non condensables in refrigerant.	Check for non condensables in refrigerant.	In case of suspicion of non condensables, recover, vacuum and recharge with virgin refrigerant.
Stop valve is closed.	Check stop valve.	Open stop valve when required.
Faulty power module = faulty outdoor inverter PCB.	Check outdoor inverter PCB. Check if the HAP LED is blinking in regular intervals. Check if the correct spare part is installed.	Restore the power to the outdoor inverter PCB. Replace the outdoor inverter PCB when required.
Faulty compressor.	Check compressor. Check connections and wiring of the compressor. Check expansion valve (liquid back issue). Check the refrigerant charge. Refer to the nameplate for correct charge.	Replace compressor when required. Investigate reason of breakdown. Replace expansion valve when required. Fix possible leak.
Faulty or disturbance of the power supply (imbalance > 10%). Power drop. Short circuit.	Check if the power supply is conform with regulations. No fluctuations in frequency.	Adjust power supply when required. Power reset via outdoor unit.

More info:

	INFORMATION The Inverter PCB and Main PCB are 1 PCB in this unit.
---	---

Check procedures	Replacing procedures
"Main PCB" on page 50	"Replacing main PCB" on page 80
"Compressor" on page 46	"Replacing compressor" on page 72
"Electronic expansion valve" on page 48	"Replacing expansion valve body" on page 77

2.2.2.23. "P4-00" – Radiating fin temperature sensor abnormality

Trigger	Effect	Reset
Radiating fin thermistor input voltage is < 0.04 V or > 4.96 V when power is on.	Unit will stop operating.	Manual reset via user interface.

Possible cause	Check	Corrective action
Faulty radiating fin thermistor.	Check radiating fin thermistor.	Replace radiating fin thermistor when required.
Faulty outdoor unit PCB in which radiating fin thermistor is connected.	Check if the HAP LED is blinking in regular intervals. Check if the correct spare part is installed. Check if the outdoor main PCB receives power.	Restore the power to the outdoor main PCB. Replace outdoor main PCB when HAP LED is not blinking in regular intervals.

More info:

Check procedures	Replacing procedures
"Refrigerant thermistors" on page 51	"Replacing thermistors" on page 82
"Main PCB" on page 50	"Replacing main PCB" on page 80

2.2.3. System

2.2.3.1. "U0-00" – Refrigerant shortage

Trigger	Effect	Reset
Refrigerant shortage detected.	Unit will stop operating.	Automatic reset. Power reset via outdoor unit.

Possible cause	Check	Corrective action
Faulty air thermistor.	Check air thermistor.	Replace air thermistor when required.
Faulty discharge thermistor.	Check discharge thermistor.	Replace discharge thermistor when required.
Faulty outdoor heat exchanger thermistor.	Check outdoor heat exchanger thermistor.	Replace outdoor heat exchanger thermistor when required.
Stop valve is closed.	Check stop valve.	Open stop valve when required.
Refrigerant shortage.	Check for refrigerant shortage. Refer to the nameplate for the correct charge.	Charge the correct refrigerant amount when required.
Humidity in refrigerant (ice formation in expansion valve).	Check for humidity in the refrigerant.	In case of suspicion of humidity, recover, vacuum and recharge with virgin refrigerant.
Non condensables in refrigerant.	Check for non condensables in refrigerant.	In case of suspicion of non condensables, recover, vacuum and recharge with virgin refrigerant.
Faulty compressor.	Check compressor. Check connections and wiring of the compressor. Check expansion valve (liquid back issue). Check the refrigerant charge. Refer to the nameplate for the correct charge.	Replace compressor when required. Investigate reason of breakdown. Replace expansion valve when required. Fix possible leak.
Faulty expansion valve.	Check the expansion valve.	Replace the expansion valve body or motor when required.

More info:

Check procedures	Replacing procedures
"Refrigerant thermistors" on page 51	
"Compressor" on page 46	"Replacing compressor" on page 72
"Electronic expansion valve" on page 48	"Replacing expansion valve body" on page 77 "Replacing expansion valve motor" on page 78
"Error codes" on page 101	

2.2.3.2. "U2-00" – Power supply abnormality or instantaneous power failure

Trigger	Effect	Reset
There is no zero-cross detected in approximately 10 seconds (indoor unit PCB).	Unit will stop operating.	Power reset via outdoor unit.
Abnormal voltage drop (< 150-180 V) is detected by the DC voltage detection circuit.	Unit will stop operating.	Automatic restart after compressor stand-by of 3 minutes.
Abnormal voltage rise is detected by the over-voltage detection circuit.	Unit will stop operating.	Automatic restart after compressor stand-by of 3 minutes.

Possible cause	Check	Corrective action
Faulty or disturbance of the power supply (imbalance > 10%). Power drop. Short circuit.	Check if the power supply is conform with regulations. No fluctuations in frequency.	Adjust power supply when required. Power reset via outdoor unit.
Defective DC voltage detection circuit.	Check PCB with DC voltage detection circuit.	Replace PCB when required.
Defective over-voltage detection circuit.	Check PCB with over-voltage detection circuit.	Replace PCB when required.
Defective PAM control part.	Check PAM control part.	Replace PAM control part when required.
Faulty compressor.	Check compressor. Check connections and wiring of the compressor. Check expansion valve (liquid back issue). Check the refrigerant charge. Refer to the nameplate for correct charge.	Replace compressor when required. Investigate reason of breakdown. Replace expansion valve when required. Fix possible leak.
Faulty outdoor fan motor.	Check the fan motor. Check fan motor connections and wiring.	Replace fan motor when required. Adjust wiring when required.
Momentary drop of voltage.	-	Wait until compressor restarts.
Momentary power failure.	-	Wait until compressor restarts.
Faulty outdoor unit main PCB.	Check if the HAP LED is blinking in regular intervals. Check if the correct spare part is installed. Check if the outdoor main PCB receives power.	Restore the power to the outdoor main PCB. Replace outdoor main PCB when HAP LED is not blinking in regular intervals.
Faulty indoor unit main PCB.	Check if the HAP LED is blinking in regular intervals. Check if the correct spare part is installed. Check if the indoor main PCB receives power.	Restore the power to the indoor main PCB. Replace indoor main PCB when HAP LED is not blinking in regular intervals.

More info:

Check procedures	Replacing procedures
"Compressor" on page 46	"Replacing compressor" on page 72
"Electronic expansion valve" on page 48	"Replacing expansion valve body" on page 77
"Fan motor" on page 50	"Replacing DC fan motor assembly" on page 75
"Main PCB" on page 50	"Replacing main PCB" on page 80

2.2.3.3. "U3-00" – Check operation not executed or transmission error

Trigger	Effect	Reset
Failed wiring error check operation. Wiring issue between indoor and outdoor.	Unit will not start to run.	To reset the error code: push SW3 (wiring error check switch) for 10 seconds. For more information, see installation manual "wiring error check".

Possible cause	Check	Corrective action
Stopped operation before finishing wiring check operation.	Measure the voltage at the primary side of the safety breaker. Check that all liquid and gas valves are fully open. Check piping & wiring match.	Reset error code and restart wiring error check procedure.

Possible cause	Check	Corrective action
No self-correction possible.	Outdoor temperature below 5°C.	Check wiring and piping in the usual manner.
More than 3 wrong connections.	Check piping & wiring match.	Check wiring and piping in the usual manner.
No correct wiring.	Check piping & wiring match.	Correct wiring.

2.2.3.4. "U4-00" – Transmission abnormality between indoor unit and outdoor unit

Trigger	Effect	Reset
Data sent from outdoor unit cannot be received normally, content of the send data is abnormal.	Unit will stop operating.	Power reset via outdoor unit.

Possible cause	Check	Corrective action
Faulty or disturbance of the power supply (imbalance > 10%). Power drop. Short circuit.	Check if the power supply is conform with regulations. No fluctuations in frequency.	Adjust power supply when required. Power reset via outdoor unit.
Wiring abnormality between indoor unit and outdoor unit.	Check wiring between indoor unit and outdoor unit.	Adjust wiring between indoor unit and outdoor unit when required. Replace wiring between indoor unit and outdoor unit when required.
Faulty outdoor unit main PCB.	Check if the HAP LED is blinking in regular intervals. Check if the correct spare part is installed. Check if the outdoor main PCB receives power.	Restore the power to the outdoor main PCB. Replace outdoor main PCB when HAP LED is not blinking in regular intervals.
Faulty outdoor fan motor.	Check the fan motor. Check fan motor connections and wiring.	Replace fan motor when required. Adjust wiring when required.
Faulty indoor unit main PCB.	Check if the HAP LED is blinking in regular intervals. Check if the correct spare part is installed. Check if the indoor main PCB receives power.	Restore the power to the indoor main PCB. Replace indoor main PCB when HAP LED is not blinking in regular intervals.
Standby electricity saving mode is ON but there is a sky-air indoor installed on the unit.	If the indoor unit is NOT a sky-air indoor. This mode is only compatible with split indoor units.	Put "standby electricity saving function" OFF (see installation manual).

More info:

Check procedures	Replacing procedures
"Main PCB" on page 50	"Replacing main PCB" on page 80
"Fan motor" on page 50	"Replacing DC fan motor assembly" on page 75

2.2.3.5. "U5-00" – Malfunction of transmission between indoor unit and remote controller

Trigger	Effect	Reset
Data from indoor unit cannot be send to wired controller and vice-versa.	Unit cannot be controlled by the wired controller.	If the connection is correct the unit will start itself.

Possible cause	Check	Corrective action
Faulty wiring.	Double check if the wiring is correct. It can be that the connector is the same but not the cables. Use the cable who comes with the controller.	Correct wiring.

2.2.3.6. “U7-00” – Transmission outdoor unit-outdoor unit abnormality

Trigger	Effect	Reset
Communication abnormality between outdoor unit PCB's.	Unit will stop operating.	Manual reset via user interface.

Possible cause	Check	Corrective action
Faulty wiring between outdoor unit PCBs.	Check wiring between outdoor unit PCBs.	Adjust wiring between outdoor unit PCBs when required.
Faulty outdoor unit main PCB.	Check if the HAP LED is blinking in regular intervals. Check if the correct spare part is installed. Check if the outdoor main PCB receives power.	Adjust the power to the outdoor main PCB. Replace outdoor main PCB when HAP LED is not blinking in regular intervals.
Faulty outdoor inverter PCB.	Check outdoor inverter PCB. Check if the alive led is blinking in regular intervals. Check if the correct spare part is installed.	Adjust the power to the outdoor inverter PCB. Replace outdoor inverter PCB.

More info:

Check procedures	Replacing procedures
	"Replacing main PCB" on page 80

2.2.3.7. “UA-00” – Improper combination of indoor unit and outdoor unit

Trigger	Effect	Reset
Signal transmission between indoor unit and outdoor unit abnormality.	Unit will stop operating.	Power reset via outdoor unit.

Possible cause	Check	Corrective action
Improper combination of indoor unit and outdoor unit.	Check combination.	Adjust installation when required.
Wiring abnormality between indoor unit and outdoor unit.	Check wiring between indoor unit and outdoor unit.	Adjust wiring between indoor unit and outdoor unit when required. Replace wiring between indoor unit and outdoor unit when required.
Faulty outdoor unit main PCB.	Check if the HAP LED is blinking in regular intervals. Check if the correct spare part is installed. Check if the outdoor main PCB receives power.	Restore the power to the outdoor main PCB. Replace outdoor main PCB when HAP LED is not blinking in regular intervals.

Possible cause	Check	Corrective action
Faulty indoor unit main PCB.	Check if the HAP LED is blinking in regular intervals. Check if the correct spare part is installed. Check if the indoor main PCB receives power.	Restore the power to the indoor main PCB. Replace indoor main PCB when HAP LED is not blinking in regular intervals.
Standby electricity saving mode is ON but there is a sky-air indoor installed on the unit.	If the indoor unit is NOT a sky-air indoor. This mode is only compatible with split indoor units.	Put "standby electricity saving function" OFF (see installation manual).

More info:

Check procedures	Replacing procedures
"Main PCB" on page 50	"Replacing main PCB" on page 80

2.2.3.8. "UF-00" – Wiring and piping mismatch

Trigger	Effect	Reset
When the interunit wiring between indoor and outdoor unit is incorrect. Piping abnormality.	Unit will stop operating.	Automatic reset.

Possible cause	Check	Corrective action
Faulty wiring between indoor and outdoor unit.	Check wiring between indoor and outdoor unit.	Correct wiring.
Refrigerant shortage (incorrect charge/leakage).	Check for refrigerant shortage. Perform a leak test.	If required, repair the leak and charge the correct amount of refrigerant.
Refrigerant circuit is clogged.	Check for possible blockage (Blockages can be checked by measuring the refrigerant/pipe temperature. Sudden drop in temperature could indicate a blockage. (Remark: This is not valid for the expansion valve.)).	

More info:

Check procedures	Replacing procedures
"Wiring diagram" on page 92	

2.2.4. Others

Not applicable.

2.3. Symptom based troubleshooting

2.3.1. Indoor unit

Not available yet.

2.3.2. Outdoor unit

Not available yet.

2.3.3. System

Not applicable.

2.3.4. Others

Not applicable.

2.4. Component checklist

Overview of component checklists:

Indoor unit.....	43
Fan motor	43
Outdoor unit.....	44
4-way valve.....	44
Compressor	46
Electronic expansion valve	48
Fan motor	50
Main PCB	50
Refrigerant thermistors	51
System.....	54
Others	54

2.4.1. Indoor unit

2.4.1.1. Fan motor

Technical specification		Description	
The motor has a single connector for DC power and the rotation counter feed back from the integrated pulse generator (4 pulses/revolution).		The fan motor runs on a fixed speed to supply the required air flow rate.	
Location			
Piping diagram	Wiring diagram	Switch box	Component overview of unit
See "Indoor unit" on page 98.	See "Indoor unit" on page 92.	Not applicable.	Not applicable.
Check procedure			
Mechanical check			

PRELIMINARY ACTIONS

1. Switch off the Daikin unit via the user interface.
2. Switch off the Daikin unit with the field supplied circuit breaker.
3. Remove casing when required.

PROCEDURE

1. Check the state of the rotor, replace the rotor if damaged, deformed, cracked or broken.
2. Check the motor shaft bearing friction, only perform electrical check if motor runs with low shaft bearing friction. Replace fan motor if friction is abnormal.

Electrical check

PRELIMINARY ACTIONS

1. Switch off the Daikin unit via the user interface.
2. Switch off the Daikin unit with the field supplied circuit breaker.
3. Remove casing when required.

PROCEDURE

1. Check fuse on indoor PCB, replace if blown.



WARNING: RISK OF FIRE

When reconnecting a connector to the PCB, do not apply force, as this may damage the connector or connector pins of the PCB.

2. Check if fan motor connector is plugged into PCB.
3. Power the Daikin unit.
4. Check power supply, the measured voltage must be 198 - 240 VAC, if not replace indoor PCB.

2.4.2. Outdoor unit

2.4.2.1. 4-way valve

Technical specification		Description	
-		The 4-way valve directs the super heated refrigerant discharged from the compressor to the indoor heat exchanger in case of heating operation or to the outdoor heat exchanger in case of defrosting and cooling operation.	
Location			
Piping diagram	Wiring diagram	Switch box	Component overview of unit
See "Outdoor unit" on page 98.	See "Outdoor unit" on page 97.	See "Outdoor unit" on page 101.	See "Outdoor unit" on page 100.
Check procedure			
Mechanical check			

PRELIMINARY ACTIONS

1. Switch off the Daikin unit via the user interface.
2. Switch off the Daikin unit with the field supplied circuit breaker.
3. Remove plate work when required (refer to "Basic removal" on page 64).

PROCEDURE

1. Loosen the screw and remove the coil from the 4-way valve (refer to "Replacing 4-way valve coil" on page 71).



WARNING: RISK OF FIRE

When reconnecting a connector to the PCB, do not apply force, as this may damage the connector or connector pins of the PCB.

2. Unplug 4-way valve connector from applicable PCB, see table "Component checklist" on page 101.
3. Switch the circuit breaker on.
4. Switch on the Daikin unit via the user interface, start cooling/defrost operation.
If the temperature after the heat exchanger drops, proceed with next step.
If the temperature after the heat exchanger rises, the 4-way valve is stuck in heating position, replace the 4-way valve body (refer to "Replacing 4-way valve body" on page 69).
If the temperature after the heat exchanger does not rise, check the refrigerant pressure by connecting a manifold to one of the service ports.
 - If no pressure is measured, perform a pressure test and fix any leaks.
 - If pressure is measured, the 4-way valve is stuck in the middle, confirm by determining the position of the 4-way valve as described below and replace the 4-way valve (refer to "Replacing 4-way valve body" on page 69).



CAUTION - RISK OF LIQUID ENTERING THE COMPRESSOR

To prevent damage to the compressor the step below must only be done once.

5. While listening to the 4-way valve, place a round permanent magnet on the core of the solenoid valve. If you do not hear the 4-way valve switching, it must be replaced (refer to "Replacing 4-way valve body" on page 69).

Electrical check

PRELIMINARY ACTIONS

1. Switch off Daikin unit via the user interface.
2. Switch off Daikin unit with the field supplied circuit breaker.
3. Remove plate work when required (refer to ["Basic removal" on page 64](#)).

PROCEDURE

1. Switch on the Daikin unit, start heating operation.

**WARNING: RISK OF FIRE**

When reconnecting a connector to the PCB, do not apply force, as this may damage the connector or connector pins of the PCB.

2. Measure the voltage on 4-way valve connector: pin 1-3, see table ["Component checklist" on page 101](#). If the measured voltage does not range 220-240 VAC during switching / 15 VAC after switching, unplug 4-way valve connector from PCB and measure the voltage directly on the PCB: pin 1-3 of 4-way valve connection.
 - If the voltage, measured directly on the PCB does not range 220-240 VAC during switching / 15 VAC after switching, replace main PCB.
 - If the voltage, measured directly on the PCB does range 220-240 VAC during switching / 15 VAC after switching, replace the 4-way valve coil (refer to ["Replacing 4-way valve coil" on page 71](#)).

**WARNING: RISK OF FIRE**

When reconnecting a connector to the PCB, do not apply force, as this may damage the connector or connector pins of the PCB.

3. Unplug 4-way valve connector from PCB and measure the resistance of the 4-way valve coil. If the measured resistance does not range 1000 - 2000 Ω , replace the 4-way valve coil (refer to ["Replacing 4-way valve coil" on page 71](#)).
4. Switch on the Daikin unit, start cooling/defrost operation.

If the temperature after the plate type heat exchanger rises, the control of the 4-way valve is wrong. Replace main PCB.

Determine the position of the 4-way valve

1. Switch off Daikin unit via the user interface.
2. Switch off Daikin unit with the field supplied circuit breaker.
3. Slide a magnet over the front and the rear of the 4-way valve body and sense the attraction of the magnet to determine the valve position.
4. If the magnet is attracted in positions A,A' or B,B', the 4-way valve is OK; if the magnet is attracted in positions C,C' the 4-way valve must be replaced (refer to ["Replacing 4-way valve body" on page 69](#)).

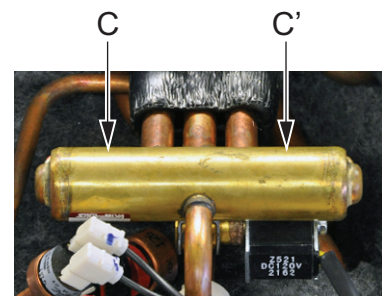
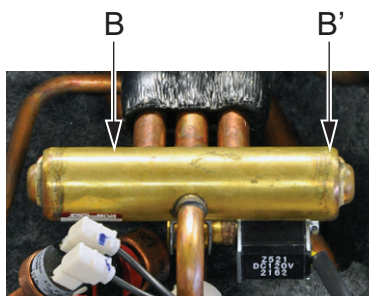
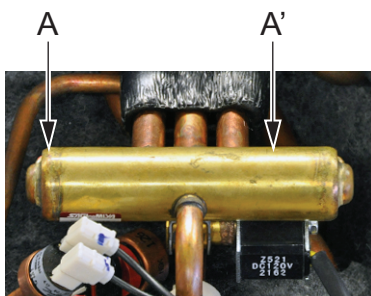

2.4.2.2. Compressor

Technical specification		Description	
Type: inverter driven, swing double swing.		The compressor compresses the refrigerant in the refrigerant circuit.	
Location			
Piping diagram	Wiring diagram	Switch box	Component overview of unit
See "Outdoor unit" on page 98.	See "Outdoor unit" on page 97.	See "Outdoor unit" on page 101.	See "Outdoor unit" on page 100.
Check procedure			
Preliminary check			

1. Check if the Daikin unit is connected to earth.
2. Check if the stop valve is open.

Mechanical check

PRELIMINARY ACTIONS

1. Switch off the Daikin unit via the user interface.
2. Switch off the Daikin unit with the field supplied circuit breaker.
3. Remove plate work when required (refer to "Basic removal" on page 64).

PROCEDURE

1. Open the compressor insulation.
2. Check if the condition of the compressor dampers and piping is correct.

Electrical check

PRELIMINARY ACTIONS

1. Switch off the Daikin unit via the user interface.
2. Switch off the Daikin unit with the field supplied circuit breaker.
3. Remove plate work when required.

PROCEDURE

1. Open the compressor insulation.
2. Switch on the Daikin unit and measure the U, V, W inverter voltages. All voltages must be identical, if not, replace the inverter PCB.
3. Switch off the Daikin unit via the user interface.
4. Switch off the Daikin unit with the field supplied circuit breaker.



INFORMATION

Note the position of the cables on the compressor wire terminals to allow identical wiring during reinstallation.

5. Disconnect the Faston connectors U, V and W from the compressor, take picture.
6. Measure the compressor motor windings U-V, V-W and U-W.

7. Megger the compressor using 500 or 1000 VDC, the insulation must be higher than 3 MΩ.
8. Replace the compressor if the windings and/or insulation measurements fail (refer to ["Replacing compressor" on page 72](#)).
9. Run the compressor and measure the current in each phase; the current for each phase should be identical (refer to ["Product specific information" on page 101](#)). In that case it can be decided to preventively replace the compressor (refer to ["Replacing compressor" on page 72](#)).

2.4.2.3. Electronic expansion valve

Technical specification		Description	
The electronic expansion valve has a hermetically sealed body with a slide-on stepping motor drive coil (480 pulses from fully closed to fully open position).		The electronic expansion valve is used: <ul style="list-style-type: none"> To control the flow of refrigerant. Depending on location, the trigger point is sub-cool and/or superheat. To stop the flow of refrigerant completely when closing (= 0 pulses). 	
Location			
Piping diagram	Wiring diagram	Switch box	Component overview of unit
See "Outdoor unit" on page 98.	See "Outdoor unit" on page 97.	See "Outdoor unit" on page 101.	See "Outdoor unit" on page 100.
Check procedure			
Mechanical check			

PRELIMINARY ACTIONS

- Switch off the Daikin unit via the user interface.
- Switch off the Daikin unit with the field supplied circuit breaker.
- Switch on the Daikin unit and listen to the expansion valve assembly, if the expansion valve body does not create a latching sound, continue with the electrical check.
- Switch off the Daikin unit via the user interface.
- Switch off the Daikin unit with the field supplied circuit breaker.
- Remove plate work when required (refer to "Basic removal" on page 64).

PROCEDURE

- Remove the expansion valve coil from the expansion valve body.
- Slide the magnet (tool part N° 9950038) over the expansion valve body and gently rotate the magnet to manually operate the expansion valve body clockwise (closing) and counterclockwise (opening).
- If it is not possible to open the expansion valve body with the magnet, the expansion valve body is blocked and the expansion valve body must be replaced (refer to "Replacing expansion valve body" on page 77).

Electrical check

PRELIMINARY ACTIONS

- Switch off the Daikin unit via the user interface.
- Switch off the Daikin unit with the field supplied circuit breaker.
- Remove plate work when required (refer to "Basic removal" on page 64).

PROCEDURE

- Check if the electrical connector of the expansion valve coil was correctly connected to the PCB, if not, connect the electrical connector.
- Disconnect the electrical connector of the expansion valve coil and check the continuity between below pins using a multi meter. It should be \pm the same value.
 - Connector pin 1-6: connected

- Connector pin 2-6: connected
- Connector pin 3-6: connected
- Connector pin 4-6: connected

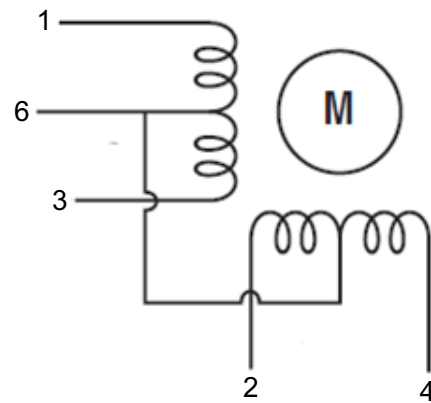
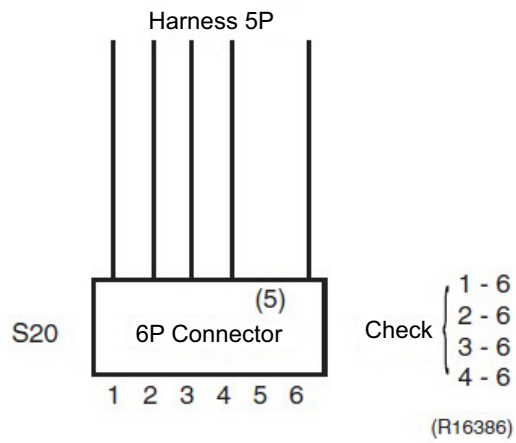

3. If one or more of the windings have no continuity, replace the expansion valve coil.

2.4.2.4. Fan motor

Technical specification		Description	
The motor has a single connector for DC power and the rotation counter feed back from the integrated pulse generator (4 pulses/revolution).		The fan motor runs on a fixed speed to supply the required air flow rate.	
Location			
Piping diagram	Wiring diagram	Switch box	Component overview of unit
See "Outdoor unit" on page 98.	See "Outdoor unit" on page 97.	See "Outdoor unit" on page 101.	See "Outdoor unit" on page 100.
Check procedure			
Mechanical check			

PRELIMINARY ACTIONS

1. Switch off the Daikin unit via the user interface.
2. Switch off the Daikin unit with the field supplied circuit breaker.
3. Remove plate work when required (refer to "Basic removal" on page 64).

PROCEDURE

1. Check the state of the propeller, replace the propeller if damaged, deformed, cracked or broken (refer to "Replacing propeller fan blade assembly" on page 81).
2. Check the motor shaft bearing friction, only perform electrical check if motor runs with low shaft bearing friction. Replace fan motor if friction is abnormal (refer to "Replacing DC fan motor assembly" on page 75).

Electrical check

PRELIMINARY ACTIONS

1. Switch off the Daikin unit via the user interface.
2. Switch off the Daikin unit with the field supplied circuit breaker.
3. Remove plate work when required (refer to "Basic removal" on page 64).

PROCEDURE

1. Check fuse on PCB, replace if blown, see table "Component checklist" on page 101.



WARNING: RISK OF FIRE

When reconnecting a connector to the PCB, do not apply force, as this may damage the connector or connector pins of the PCB.

2. Check if fan motor connector is plugged into PCB.
3. Power the Daikin unit.
4. Check power supply, the measured voltage must be 198 - 240 VAC, if not replace main PCB (refer to "Replacing main PCB" on page 80).

2.4.2.5. Main PCB

Not available yet.

2.4.2.6. Refrigerant thermistors

Technical specification		Description	
A single type of thermistor is used; the resistance vs. temperature characteristics is shown in below table "Thermistor resistance / temperature characteristics (type 1)".		The thermistors are used to measure the temperature at multiple locations inside the Daikin unit. The measured temperatures are processed by the main board.	
Location			
Piping diagram	Wiring diagram	Switch box	Component overview of unit
See "Outdoor unit" on page 98.	See "Outdoor unit" on page 97.	See "Outdoor unit" on page 101.	See "Outdoor unit" on page 100.
Check procedure			
Mechanical check			

PRELIMINARY ACTIONS

1. Switch off the Daikin unit via the user interface.
2. Switch off the Daikin unit with the field supplied circuit breaker.
3. Locate the thermistor and check if thermal contact with the piping or ambient is ensured.

Electrical check



INFORMATION

If a thermistor check fails, replace the thermistor.

PRELIMINARY ACTIONS

1. Switch off the Daikin unit via the user interface.
2. Switch off the Daikin unit with the field supplied circuit breaker.
3. Remove plate work when required.

PROCEDURE

1. From the table in the appendix ("[Component checklist](#)" on page 101), select the thermistor that must be checked.
2. Measure the temperature of the thermistor using a contact thermometer.



WARNING: RISK OF FIRE

When reconnecting a connector to the PCB, do not apply force, as this may damage the connector or connector pins of the PCB.

3. Unplug the connector from the appropriate PCB and measure the resistance between the pins listed in the table in the appendix ("[Component checklist](#)" on page 101).
 - Compare the measured resistance with the range determined by the lower and higher temperature.
4. If the measured resistance does not match the listed value, the thermistor must be replaced.



INFORMATION

All thermistors have a tolerance of 5%.

E.g. R3T air thermistor - main PCB - connector S90: pin 1-2 type 1:

- Measured temperature with contact thermometer: 23.1°C.
- Unplug the sensor and measure the resistance between S90: 1-2: 21.86 kΩ.

- The resistance values are defined by below table "Thermistor resistance / temperature characteristics (type 1)":
 - Resistance at 23°C: 21.85 kΩ.
 - Resistance at 24°C: 20.90 kΩ.
- The measured value 21.86 kΩ is inside the range, thermistor R3T passes the check.

**INFORMATION**

The user interface allows to monitor most thermistors.

If the measured resistance of the thermistor matches the temperature measured with the contact thermometer but the temperature for the corresponding thermistor is not correct on the user interface display, replace applicable PCB.

Table 2-1: Thermistor resistance / temperature characteristics (type 1)

T °C	kΩ	T °C	kΩ	T °C	kΩ	T °C	kΩ	T °C	kΩ
-20	197.81	0	65.84	20	25.01	40	10.63	60	4.87
-19	186.53	1	62.54	21	23.91	41	10.21	61	4.70
-18	175.97	2	59.43	22	22.85	42	9.81	62	4.54
-17	166.07	3	56.49	23	21.85	43	9.42	63	4.38
-16	156.80	4	53.71	24	20.90	44	9.06	64	4.23
-15	148.10	5	51.09	25	20.00	45	8.71	65	4.08
-14	139.94	6	48.61	26	19.14	46	8.37	66	3.94
-13	132.28	7	46.26	27	18.32	47	8.05	67	3.81
-12	125.09	8	44.05	28	17.54	48	7.75	68	3.68
-11	118.34	9	41.95	29	16.80	49	7.46	69	3.56
-10	111.99	10	39.96	30	16.10	50	7.18	70	3.44
-9	106.03	11	38.08	31	15.43	51	6.91	71	3.32
-8	100.41	12	36.30	32	14.79	52	6.65	72	3.21
-7	95.14	13	34.62	33	14.18	53	6.41	73	3.11
-6	90.17	14	33.02	34	13.59	54	6.65	74	3.01
-5	85.49	15	31.50	35	13.04	55	6.41	75	2.91
-4	81.08	16	30.06	36	12.51	56	6.18	76	2.82
-3	76.93	17	28.70	37	12.01	57	5.95	77	2.72
-2	73.01	18	27.41	38	11.52	58	5.74	78	2.64
-1	69.32	19	26.18	39	11.06	59	5.14	79	2.55
								80	2.47

Table 2-2: Thermistor resistance / temperature characteristics (type 2)

T °C	kΩ	T °C	kΩ	T °C	kΩ	T °C	kΩ	T °C	kΩ
-20	192.08	0	64.17	20	24.45	40	10.41	60	4.87
-19	181.16	1	60.96	21	23.37	41	10.00	61	4.70
-18	170.94	2	57.94	22	22.35	42	9.61	62	4.54
-17	161.36	3	55.08	23	21.37	43	9.24	63	4.38
-16	152.38	4	52.38	24	20.45	44	8.88	64	4.23
-15	143.96	5	49.83	25	19.56	45	8.54	65	4.08
-14	136.05	6	47.42	26	18.73	46	8.21	66	3.94
-13	128.63	7	45.14	27	17.93	47	7.90	67	3.81
-12	121.66	8	42.98	28	17.17	48	7.60	68	3.68
-11	115.12	9	40.94	29	16.45	49	7.31	69	3.56
-10	108.96	10	39.01	30	15.76	50	7.04	70	3.44

T °C	kΩ	T °C	kΩ	T °C	kΩ	T °C	kΩ	T °C	kΩ
-9	103.18	11	37.18	31	15.10	51	6.78	71	3.32
-8	97.73	12	35.45	32	14.48	52	6.53	72	3.21
-7	92.61	13	33.81	33	13.88	53	6.53	73	3.11
-6	87.79	14	32.25	34	13.31	54	6.53	74	3.01
-5	83.25	15	30.77	35	12.77	55	6.29	75	2.91
-4	78.97	16	29.37	36	12.25	56	6.06	76	2.82
-3	74.94	17	28.05	37	11.76	57	5.84	77	2.72
-2	71.14	18	26.78	38	11.29	58	5.43	78	2.64
-1	67.56	19	25.59	39	10.84	59	5.05	79	2.55
								80	2.47

Table 2-3: Thermistor resistance / temperature characteristics (air thermistor FTXM-M)

T °C	kΩ	T °C	kΩ	T °C	kΩ	T °C	kΩ	T °C	kΩ
-32,5	237,01	-6,0	46,5	20,5	12,3	47,0	4,0	73,5	1,6
-32,0	229,08	-5,5	45,3	21,0	12,0	47,5	3,9	74,0	1,5
-31,5	221,45	-5,0	44,0	21,5	11,7	48,0	3,9	74,5	1,5
-31,0	214,10	-4,5	42,8	22,0	11,4	48,5	3,8	75,0	1,5
-30,5	207,02	-4,0	41,7	22,5	11,2	49,0	3,7	75,5	1,5
-30,0	200,20	-3,5	40,6	23,0	10,9	49,5	3,7	76,0	1,4
-29,5	193,64	-3,0	39,5	23,5	10,7	50,0	3,6	76,5	1,4
-29,0	187,32	-2,5	38,4	24,0	10,5	50,5	3,5	77,0	1,4
-28,5	181,22	-2,0	37,4	24,5	10,2	51,0	3,5	77,5	1,4
-28,0	175,35	-1,5	36,4	25,0	10,0	51,5	3,4	78,0	1,4
-27,5	169,70	-1,0	35,5	25,5	9,8	52,0	3,3	78,5	1,3
-27,0	164,24	-0,5	34,5	26,0	9,6	52,5	3,3	79,0	1,3
-26,5	158,99	0,0	33,6	26,5	9,4	53,0	3,2	79,5	1,3
-26,0	153,92	0,5	32,7	27,0	9,2	53,5	3,1	80,0	1,3
-25,5	149,03	1,0	31,9	27,5	9,0	54,0	3,1	80,5	1,3
-25,0	144,32	1,5	31,1	28,0	8,8	54,5	3,0	81,0	1,2
-24,5	139,77	2,0	30,3	28,5	8,6	55,0	3,0	81,5	1,2
-24,0	135,39	2,5	29,5	29,0	8,4	55,5	2,9	82,0	1,2
-23,5	131,15	3,0	28,7	29,5	8,2	56,0	2,9	82,5	1,2
-23,0	127,07	3,5	28,0	30,0	8,0	56,5	2,8	83,0	1,2
-22,5	123,13	4,0	27,3	30,5	7,9	57,0	2,8	83,5	1,1
-22,0	119,33	4,5	26,6	31,0	7,7	57,5	2,7	84,0	1,1
-21,5	115,66	5,0	25,9	31,5	7,5	58,0	2,7	84,5	1,1
-21,0	112,11	5,5	25,3	32,0	7,4	58,5	2,6	85,0	1,1
-20,5	108,69	6,0	24,6	32,5	7,2	59,0	2,6	85,5	1,1
-20,0	105,38	6,5	24,0	33,0	7,1	59,5	2,5	86,0	1,1
-19,5	102,19	7,0	23,4	33,5	6,9	60,0	2,5	86,5	1,0
-19,0	99,11	7,5	22,8	34,0	6,8	60,5	2,4	87,0	1,0
-18,5	96,13	8,0	22,3	34,5	6,6	61,0	2,4	87,5	1,0
-18,0	93,25	8,5	21,7	35,0	6,5	61,5	2,4	88,0	1,0
-17,5	90,47	9,0	21,2	35,5	6,4	62,0	2,3	88,5	1,0
-17,0	87,78	9,5	20,7	36,0	6,2	62,5	2,3	89,0	1,0
-16,5	85,19	10,0	20,2	36,5	6,1	63,0	2,2	89,5	0,9
-16,0	82,67	10,5	19,7	37,0	6,0	63,5	2,2	90,0	0,9
-15,5	80,25	11,0	19,2	37,5	5,9	64,0	2,2	90,5	0,9
-15,0	77,90	11,5	18,7	38,0	5,7	64,5	2,1	91,0	0,9
-14,5	75,63	12,0	18,3	38,5	5,6	65,0	2,1	91,5	0,9

T °C	kΩ	T °C	kΩ	T °C	kΩ	T °C	kΩ	T °C	kΩ
-14,0	73,43	12,5	17,9	39,0	5,5	65,5	2,1	92,0	0,9
-13,5	71,31	13,0	17,4	39,5	5,4	66,0	2,0	92,5	0,9
-13,0	69,25	13,5	17,0	40,0	5,3	66,5	2,0	93,0	0,9
-12,5	67,27	14,0	16,6	40,5	5,2	67,0	1,9	93,5	0,8
-12,0	65,34	14,5	16,2	41,0	5,1	67,5	1,9	94,0	0,8
-11,5	63,48	15,0	15,8	41,5	5,0	68,0	1,9	94,5	0,8
-11,0	61,68	15,5	15,5	42,0	4,9	68,5	1,9	95,0	0,8
-10,5	59,93	16,0	15,1	42,5	4,8	69,0	1,8	95,5	0,8
-10,0	58,25	16,5	14,8	43,0	4,7	69,5	1,8	96,0	0,8
-9,5	56,61	17,0	14,4	43,5	4,6	70,0	1,8	96,5	0,8
-9,0	55,03	17,5	14,1	44,0	4,5	70,5	1,7	97,0	0,8
-8,5	53,50	18,0	13,8	44,5	4,4	71,0	1,7	97,5	0,7
-8,0	52,01	18,5	13,4	45,0	4,3	71,5	1,7	98,0	0,7
-7,5	50,57	19,0	13,1	45,5	4,3	72,0	1,6	98,5	0,7
-7,0	49,18	19,5	12,8	46,0	4,2	72,5	1,6	99,0	0,7
-6,5	47,83	20,0	12,5	46,5	4,1	73,0	1,6	99,5	0,7

2.4.3. System

Not applicable.

2.4.4. Others

Not applicable.

2.5. Other capacity range

Not applicable.

Part 3. Repair

This part contains the following chapters:

Refrigerant repair procedures	57
Service tools	61
Unit specific repair procedures	62

3.1. Refrigerant repair procedures

Overview:

Refrigerant piping handling	57
Recovery procedure	57
Refrigerant pump down	59
Piping repair procedures	60

3.1.1. Refrigerant piping handling

- Make sure the applied pressure is never higher than the unit design pressure as indicated on the nameplate (PS).
- Work according the F-gas regulation and/or local regulations.
- Make sure the correct amount according the F-gas regulation label on the unit (factory + additional where required) of refrigerant is charged after repair.
- Make sure to use the appropriate equipment and tools according to the refrigerant and unit type.
- Charge non-azeotropic refrigerant (e.g. R-410A) always in a liquid state.
- R32 can be charged in gas phase.
- Make sure to use a digital scale (no charging cylinder).
- Execute correct vacuum drying procedure after repair work:
 - -0,1 MPa / -760 mmHg / -750 Torr / -1 bar for at least 1 hour.
 - Connect the unit according the available service ports, refer to ["Recovery procedure" on page 57](#).
 - Use related field setting where necessary to open expansion valve/solenoid valve.

3.1.2. Recovery procedure

3.1.2.1. Outdoor unit casing

1. Switch off the Daikin unit via the user interface.
2. Manually open the expansion valve (located on the outdoor unit).
3. Connect the vacuum pump, manifold, recovery unit and refrigerant bottle to the service port as shown below.
For the location of the service ports, refer to ["Outdoor unit" on page 98](#).

In case of 1 service port at the stop valves

Figure 3-1: 1 service port at the stop valves

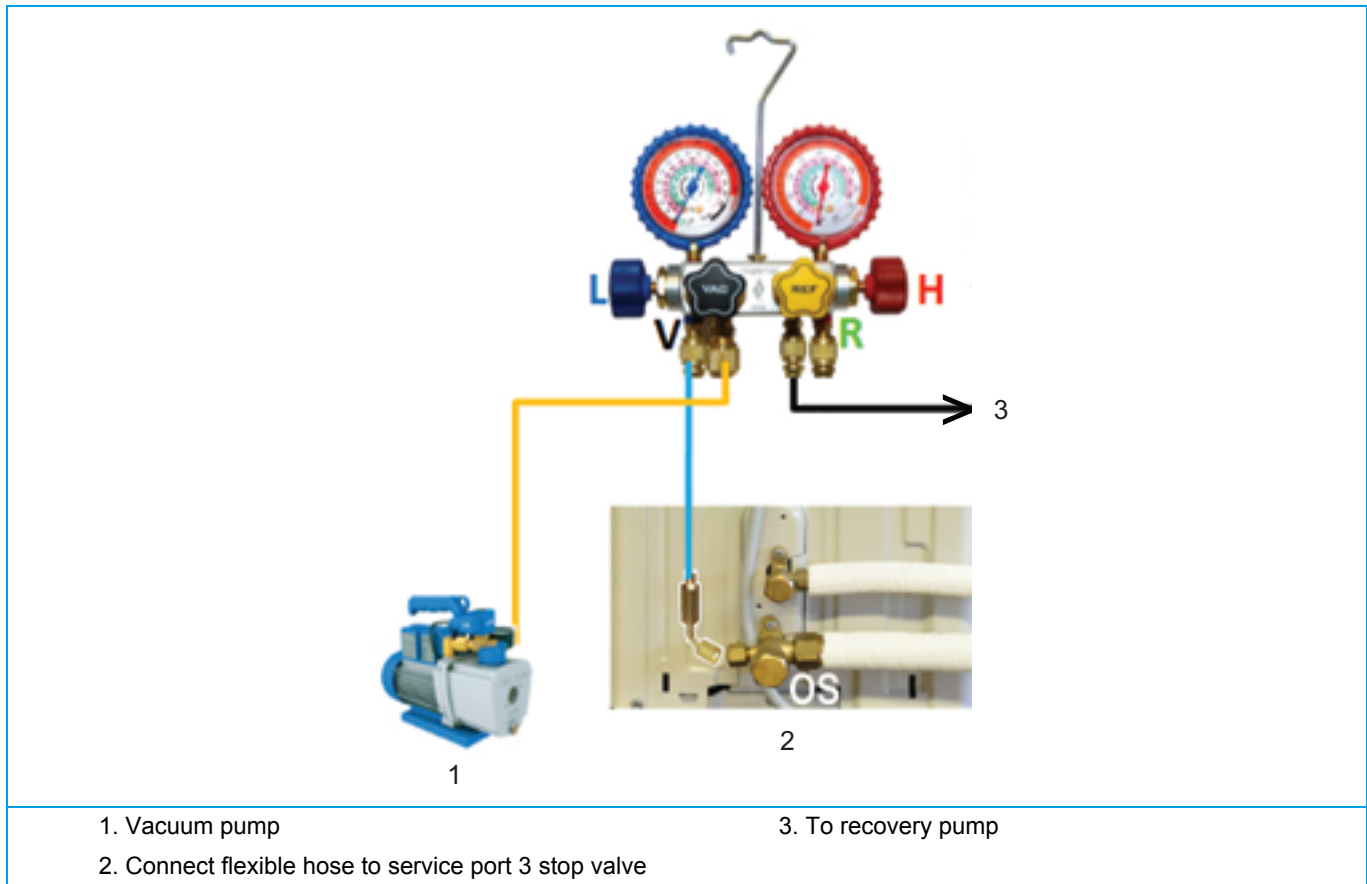

INFORMATION

See instruction of the recovery pump supplier how to recover the refrigerant.

In case of 2 service ports at the stop valves

Connect both stop valve service ports to the manifold.

In case of 3 service ports at the stop valves

Connect 1 hose to the suction stop valve service port and 1 hose to the service port between the expansion valve and outdoor H/E.

Figure 3-2: 3 service ports at the stop valves

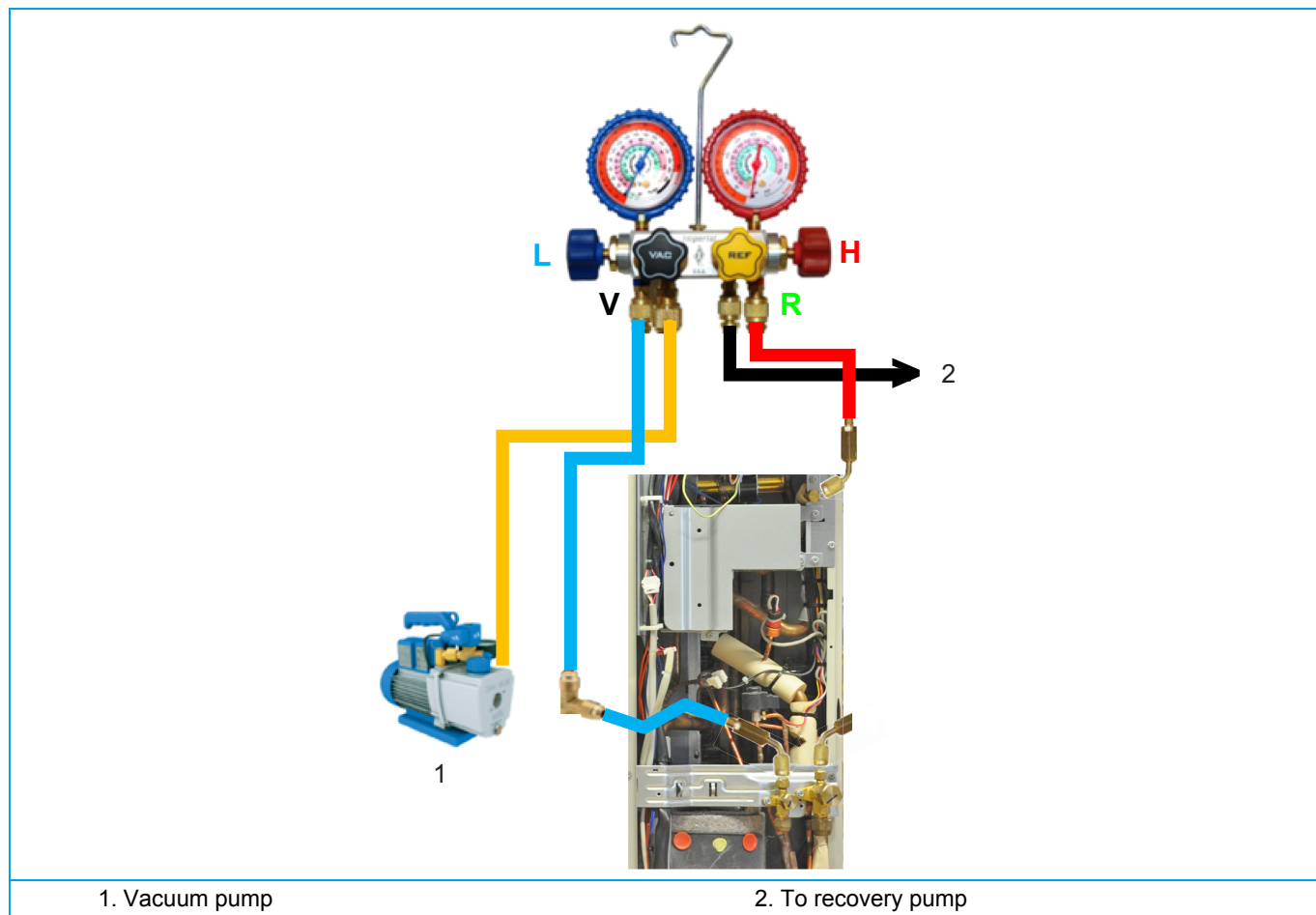
**INFORMATION**

See instruction of the recovery pump supplier how to recover the refrigerant.

3.1.3. Refrigerant pump down

This unit is equipped with an automatic pump down operation which will collect all refrigerant from the field piping and indoor unit in the outdoor unit. To protect the environment, make sure to perform the following pump down operation when relocating the unit.

**WARNING: RISK OF EXPLOSION**

- When the refrigeration circuit has a leak, do not execute pump down with the compressor.
- Use recovery system into separate cylinder.
- Warning, explosive hazard exists when executing pump down.
- Pump down with compressor can lead to self-combustion due to air entering during pump down.

**INFORMATION**

Some outdoor units are equipped with a low pressure switch to protect the compressor by switching it off. Never short-circuit the low pressure switch during pump down operation!

3.1.3.1. Small outdoor unit

1. Remove the valve lid from liquid stop valve and gas stop valve.
2. Carry out pump down operation.

**CAUTION**

Refer to Installer Reference Guide for 'Pump down operation' procedure.

3. After 5-10 min (after only 1-2 min in case of very low Ta < -10°C), close the liquid stop valve with a hexagonal wrench.
4. Check on manifold if vacuum is reached, close gas stop valve and forced cooling operation.

3.1.3.2. Large outdoor unit

1. Stop all demands for the Daikin unit.
2. Switch OFF / ON the power supply of the outdoor unit.
3. Carry out pump down operation.

**CAUTION**

Refer to Installer Reference Guide for 'Pump down operation' procedure.

4. The compressor and outdoor fan will start automatically.
5. Request heating via remote controller to prevent HE freeze-up.
6.
 - a. Check on manifold if vacuum is reached, close gas stop valve and forced cooling operation.
 - b. Once operation stops (after 3 to 5 minutes), close the liquid and the gas stop valve.
7. Pump down is now finished. U4 may be displayed on the remote controller, this is not a malfunction.
8. (After "pump down" is finished or stopped, keep the circulation pump running for at least 5 minutes.)
9. Switch OFF the power supply of the outdoor unit.

**NOTE**

- Make sure to re-open both stop valves before restart operation of the unit.
- After a finished or stopped pump down, the unit will perform a test run at first operation (same as during commissioning).

3.1.4. Piping repair procedures

- Make sure to cover open pipe ends during repair work so no dust or moisture can enter.
- Make sure to re-apply insulation removed during repair.
- Pipe expansion / flare making:
 - Remove any burrs on the cut surface and use correct tool such as reamer or scraper (note that excessive deburring can thin the pipe walls and cause cracking of the pipe).
 - Make sure the flare has the correct size (use a flare gauge).
 - Make sure no particles remain in the piping.
 - Apply just a drop of refrigerant oil on the inner surface of the flare.
 - Make sure the flare connection is tightened with the correct torque (torque values refer to installation manual).
- Brazing:
 - Use correct brazing tool.
 - Use a phosphor copper filler metal (silver composition of 0 to 2%). Do not use flux material.
 - Flush the piping before brazing with nitrogen to avoid oxidation of the inside of the copper tubes (nitrogen purity ≥ 99,99%).

3.2. Service tools

For an overview of the applicable service tools, please check the Daikin Business Portal: <http://www.mydaikin.eu>

Go to the tab “After-sales support” on the left side and then select “Technical support”.

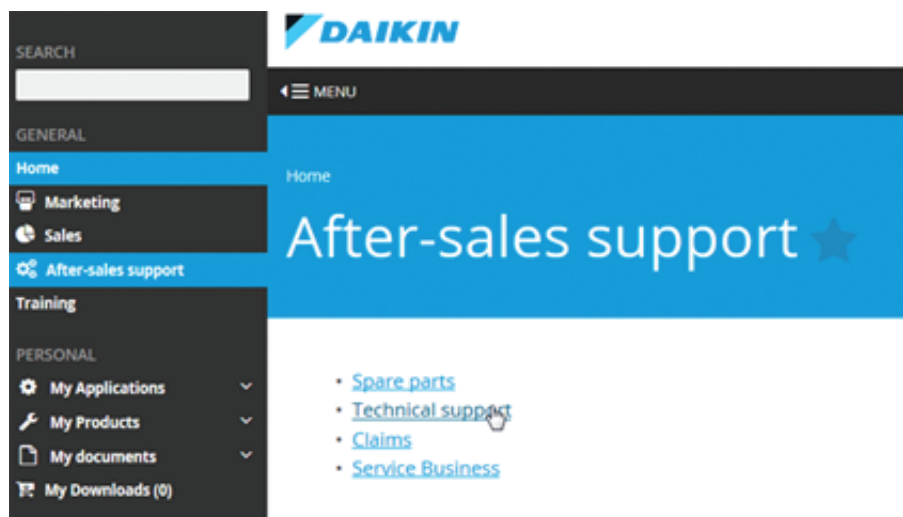

You will then find a button “Service tools” which gives you an overview on which service tool to use for which product. Also additional information on the service tool (instruction, latest software) can be found there.

3.3. Unit specific repair procedures

Overview:

Indoor unit.....	63
Outdoor unit.....	64
Basic removal.....	64
Replacing switch box.....	67
Replacing 4-way valve body.....	69
Replacing 4-way valve coil.....	71
Replacing compressor.....	72
Replacing DC fan motor assembly.....	75
Replacing expansion valve body.....	77
Replacing expansion valve motor.....	78
Replacing main PCB.....	80
Replacing propeller fan blade assembly.....	81
Replacing thermistors.....	82
Setting test mode for inverter checker.....	83

3.3.1. Indoor unit

Not available yet.

3.3.2. Outdoor unit

3.3.2.1. Basic removal

3.3.2.1.1 Single fan outdoor unit

3.3.2.1.2 Removing refrigerant connection cover

PRELIMINARY ACTIONS

1. Switch off the Daikin unit via the user interface.
2. Switch off the Daikin unit with the field supplied circuit breaker.

PROCEDURE

Removal

1. Loosen and remove 1 screw (1) that fix the refrigerant connection cover.

Figure 3-3: Removing refrigerant connection cover



1. Screw

3.3.2.1.3 Removing the top plate

PRELIMINARY ACTIONS

1. Switch off the Daikin unit via the user interface.
2. Switch off the Daikin unit with the field supplied circuit breaker.

PROCEDURE

Removal

1. Loosen and remove the 2 screws (1) that fix the top plate.

Figure 3-4: Removing the top plate



3.3.2.1.4 Removing the front plate

PRELIMINARY ACTIONS

1. Switch off the Daikin unit via the user interface.
2. Switch off the Daikin unit with the field supplied circuit breaker.

PROCEDURE

Removal

1. Remove the top plate.
2. Loosen and remove the 8 screws (1) that fix the front plate.

Figure 3-5: Removing the front plate

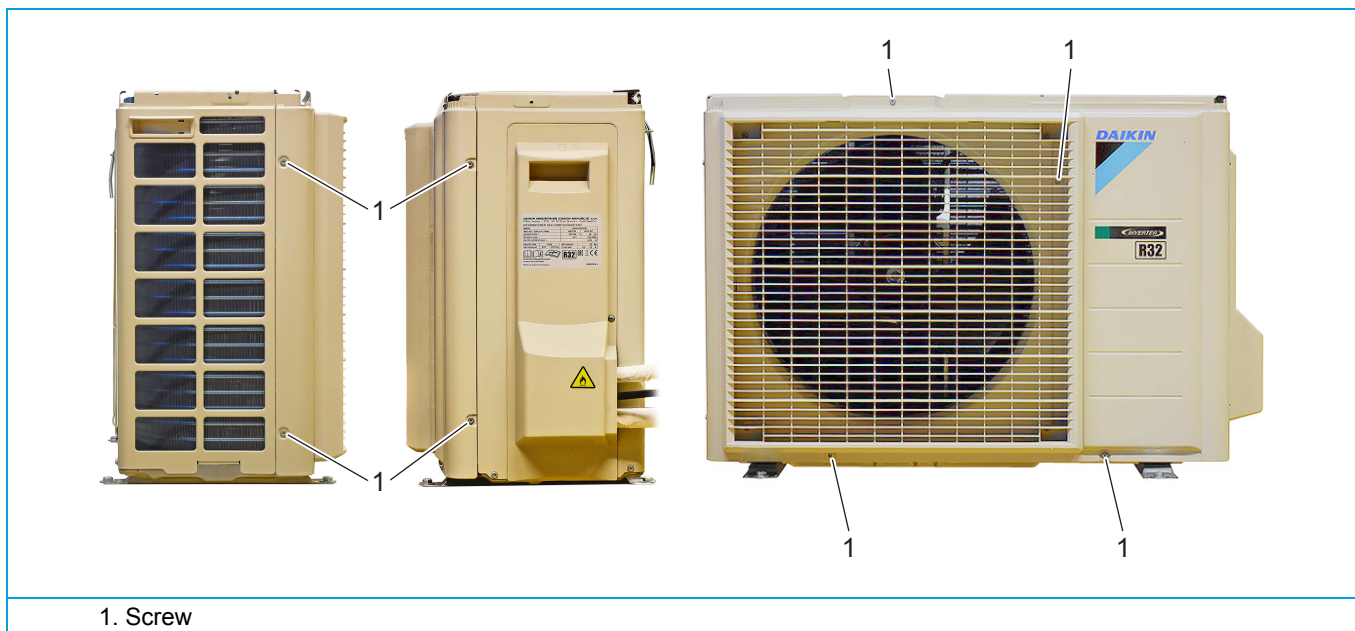

3.3.2.1.5 Removing the compressor sound insulation

PRELIMINARY ACTIONS

1. Switch off the Daikin unit via the user interface.
2. Switch off the Daikin unit with the field supplied circuit breaker.

PROCEDURE

Removal

1. Remove the top plate.
2. Remove the front plate.
3. Remove the compressor sound insulation (untwist the cord and remove the insulation).

Figure 3-6: Removing the compressor sound insulation

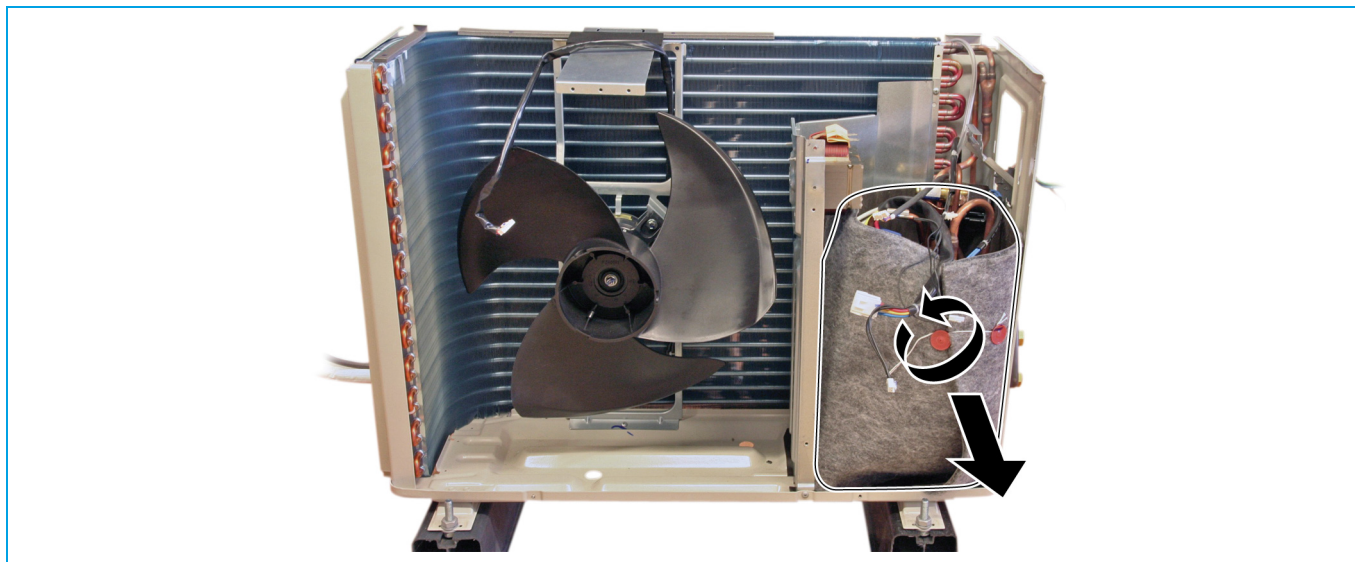

3.3.2.2. Replacing switch box

PRELIMINARY ACTIONS

1. Switch off the Daikin unit via the user interface.
2. Switch off the Daikin unit with the field supplied circuit breaker.
3. Remove plate work when required, refer to ["Basic removal" on page 64](#).

PROCEDURE

Removal

1. Remove the insulation (1).

**WARNING: RISK OF FIRE**

When reconnecting a connector to the PCB, do not apply force, as this may damage the connector or connector pins of the PCB.

2. Unplug all connectors from the main PCB (2), see ["Component checklist" on page 101](#).
3. Remove all electrical power wiring (3) from the wire terminals (4).
4. Remove the screws (5) that fix the wire clamp (6), remove the wire clamp (6).
5. Remove the screws (7) that fix the right side plate assembly (8).
6. Cut the cable tie (9).
7. Lift the switch box (10) from the Daikin unit.

Figure 3-7: Removing the switch box

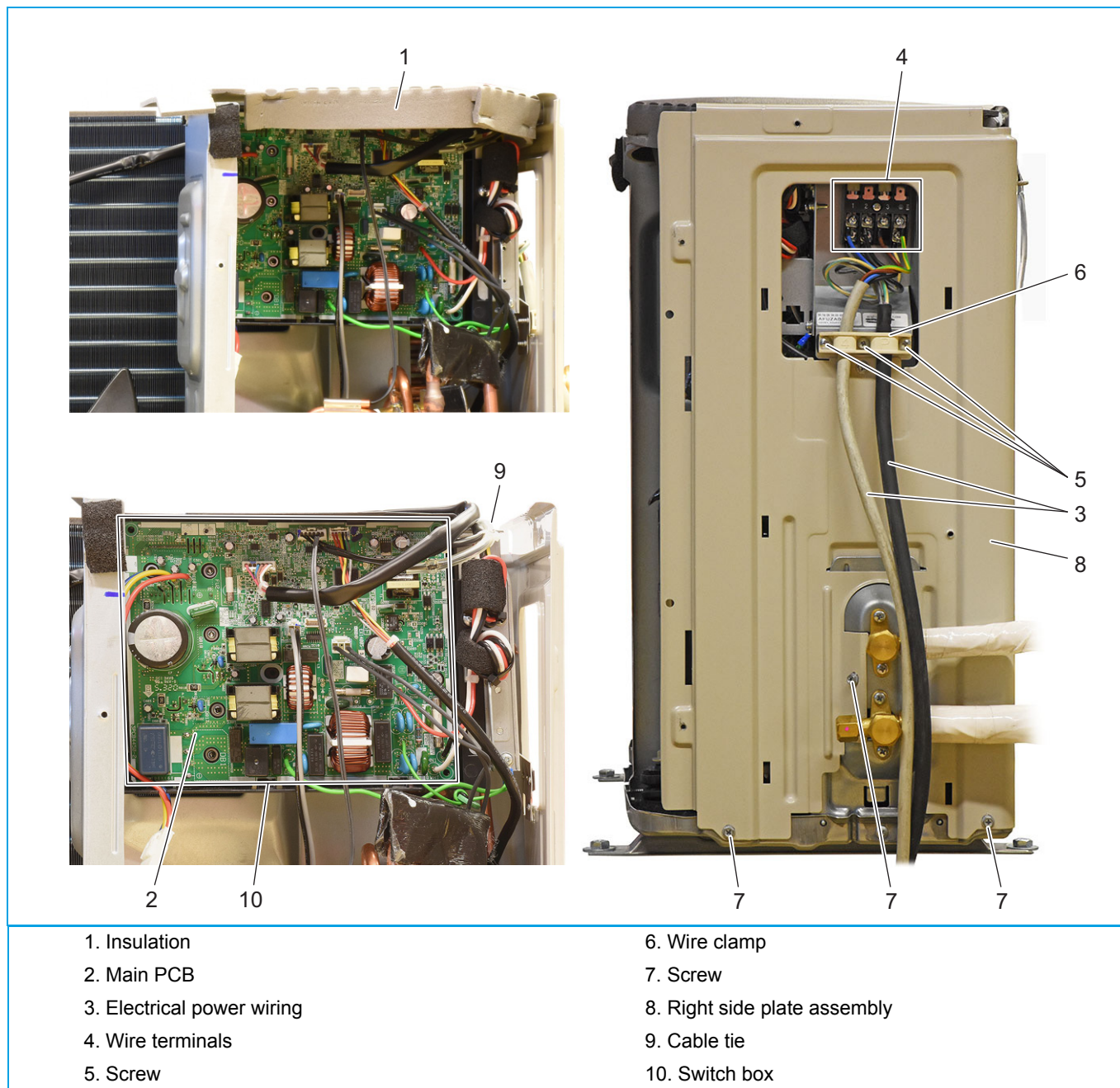

Installation

1. Proceed in reverse order.

3.3.2.3. Replacing 4-way valve body

PRELIMINARY ACTIONS

1. Switch off the Daikin unit via the user interface.
2. Switch off the Daikin unit with the field supplied circuit breaker.
3. Recover the refrigerant, refer to ["Recovery procedure" on page 57](#).
4. Remove plate work when required (refer to ["Basic removal" on page 64](#)).

PROCEDURE

Removal

1. Remove any parts that block the way to the 4-way valve.



INFORMATION

Follow local regulations and Daikin refrigerant repair procedures during the repair of your unit, refer to ["Refrigerant repair procedures" on page 57](#).



CAUTION

The maximum applied Nitrogen pressure must not exceed 0.02 MPa.

2. Cut the 4-way valve pipes (2).
3. Remove the 4-way valve (5).
4. Recuperate the putty (3).
5. Recuperate the insulation (4).

Figure 3-8: Removing the 4-way valve

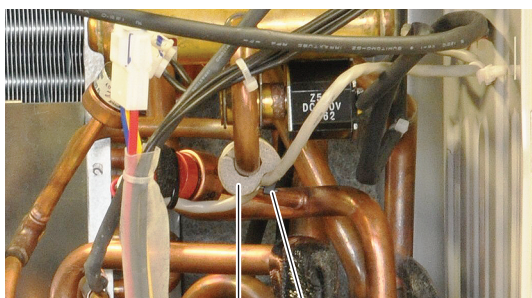

4 1

1. Tie wrap
2. 4-way valve pipe
3. Putty

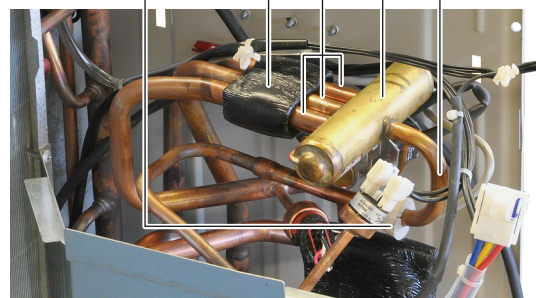

4. Insulation
5. 4-way valve

Installation



WARNING

Overheating the 4-way valve will damage or destroy it.

1. Wrap a wet rag around the 4-way valve (5).

**INFORMATION**

Install the putty on the 4-way valve.

Install the compressor sound insulation in the same location.

2. Proceed in reverse order.

3.3.2.4. Replacing 4-way valve coil

PRELIMINARY ACTIONS

1. Switch off the Daikin unit via the user interface.
2. Switch off the Daikin unit with the field supplied circuit breaker.
3. Remove plate work when required.
4. Remove any part that block the way to the 4-way valve coil.

PROCEDURE

Removal

1. Loosen and remove the screw (1) that fixes the 4-way valve coil (2).
2. Cut the tie wraps that fix the 4-way valve coil wiring.



WARNING: RISK OF FIRE

When reconnecting a connector to the PCB, do not apply force, as this may damage the connector or connector pins of the PCB.

3. Unplug 4-way valve connector from PCB.

Figure 3-9: Removing the 4-way valve coil

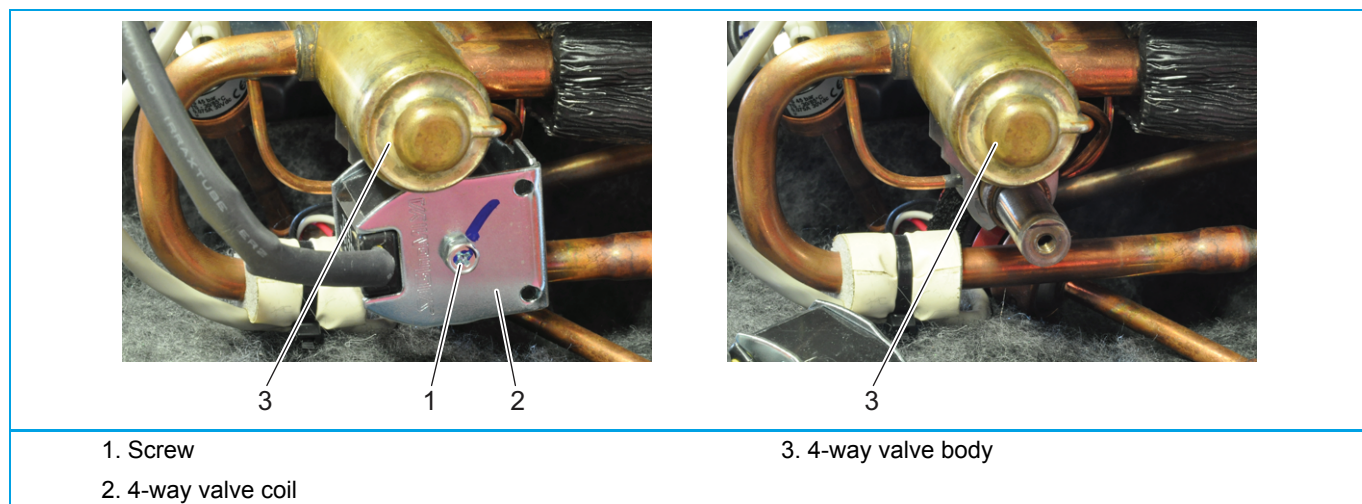

Installation

1. Proceed in reverse order.

3.3.2.5. Replacing compressor

PRELIMINARY ACTIONS

1. Switch off the Daikin unit via the user interface.
2. Switch off the Daikin unit with the field supplied circuit breaker.
3. Recover the refrigerant, refer to "[Recovery procedure](#)" on page 57.
4. Remove plate work when required.
5. Remove any part that blocks the way to the compressor.

PROCEDURE



INFORMATION

Follow local regulations and Daikin refrigerant repair procedures during the repair of your unit, refer to "[Refrigerant repair procedures](#)" on page 57.



CAUTION

The maximum applied Nitrogen pressure must not exceed 0.02 MPa.

Removal

1. Remove the terminal cover (3) and unplug the compressor wiring (4) and take picture.
2. Using a pipe cutter, cut the compressor pipes (5) below the soldered joint.
3. Loosen and remove the 3 nuts (6) that fix the compressor (7).
4. Remove the compressor (7).
5. Remove the dampers (9) with bushings (10) from the compressor (7).
6. Recuperate the putty (8).

Figure 3-10: Removing the compressor

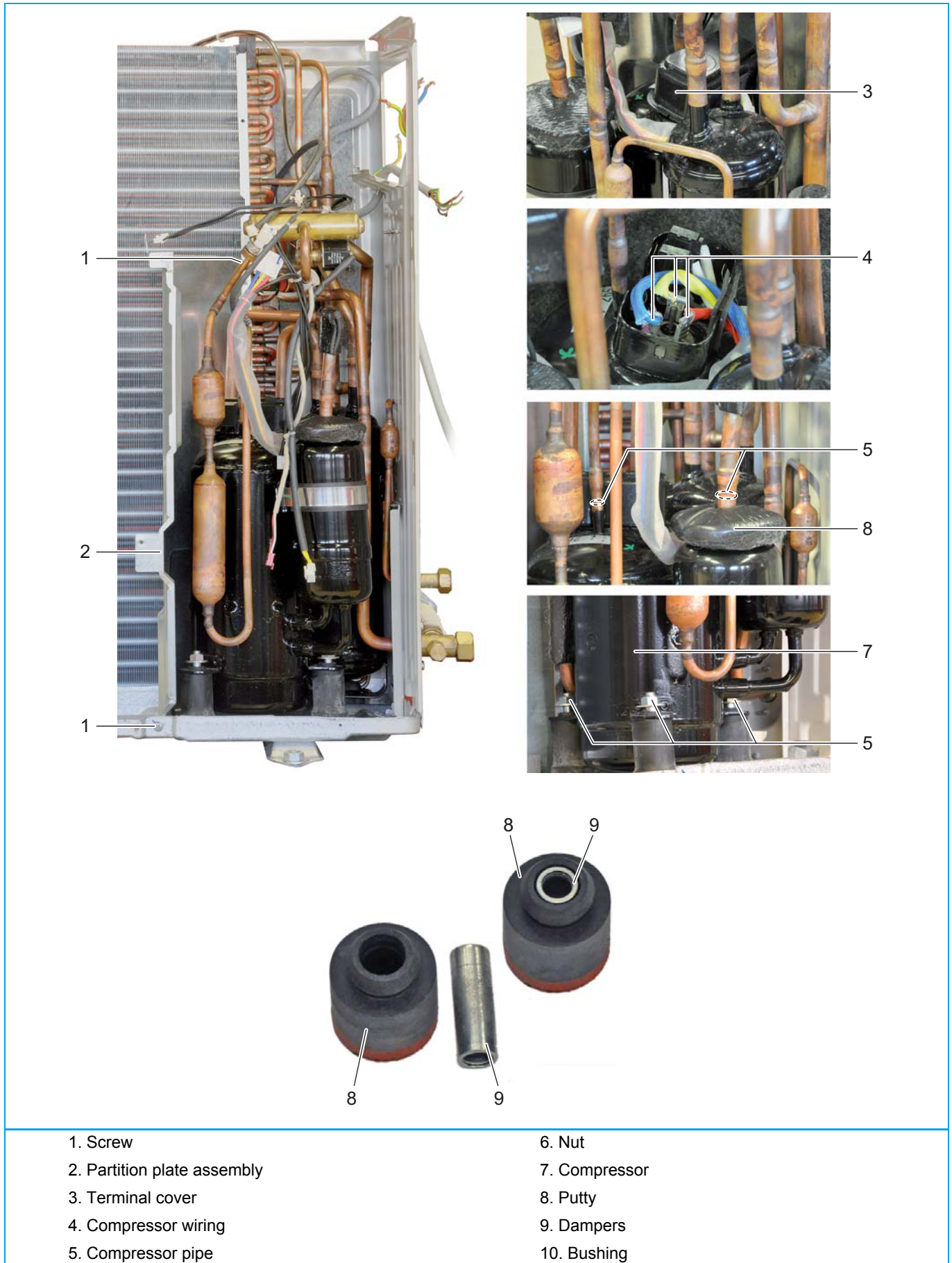

- | | |
|-----------------------------|---------------|
| 1. Screw | 6. Nut |
| 2. Partition plate assembly | 7. Compressor |
| 3. Terminal cover | 8. Putty |
| 4. Compressor wiring | 9. Dampers |
| 5. Compressor pipe | 10. Bushing |

Installation

	CAUTION
	The oil in the compressor is hygroscopic. Remove the caps from the compressor piping as late as possible.
	INFORMATION
	Before installing a new compressor, determine the cause of the compressor failure and take all required corrective actions.
	INFORMATION
	If the dampers are worn, replace the dampers. The bushings inside the dampers are recuperated for use with the new dampers.
	INFORMATION
	Install the putty on the compressor. Install the compressor sound insulation in the same location.

1. Check damper status, replace when worn.
2. First install the 3 (new) dampers (without the bushings) on the new compressor.
3. Install the 3 bushings in the dampers.
4. When installing the new compressor, remove the caps from the compression pipe and the suction pipe as late as possible.
5. When soldering the compressor pipes, cover the compressor pipes with a wet cloth to prevent overheating the compressor (and the oil in the compression pipe).
6. Proceed in reverse order.

3.3.2.6. Replacing DC fan motor assembly

PRELIMINARY ACTIONS

1. Switch off the Daikin unit via the user interface.
2. Switch off the Daikin unit with the field supplied circuit breaker.
3. Remove the propeller fan blade assembly, refer to ["Replacing propeller fan blade assembly" on page 81.](#)

PROCEDURE

Removal

1. Remove the insulation (1) from the switch box.
2. Unplug the fan motor connector (3) from the main PCB.

**WARNING: RISK OF FIRE**

When reconnecting a connector to the PCB, do not apply force, as this may damage the connector or connector pins of the PCB.

3. Release the fan motor assembly harness (2) from the slot (4).
4. Slightly bend the harness retainers (5) to release the fan motor assembly harness (2).
5. Loosen and remove the screws (6) that fix the DC fan motor assembly (7).
6. Remove the DC fan motor assembly (7).

Figure 3-11: Removing the DC fan motor assembly

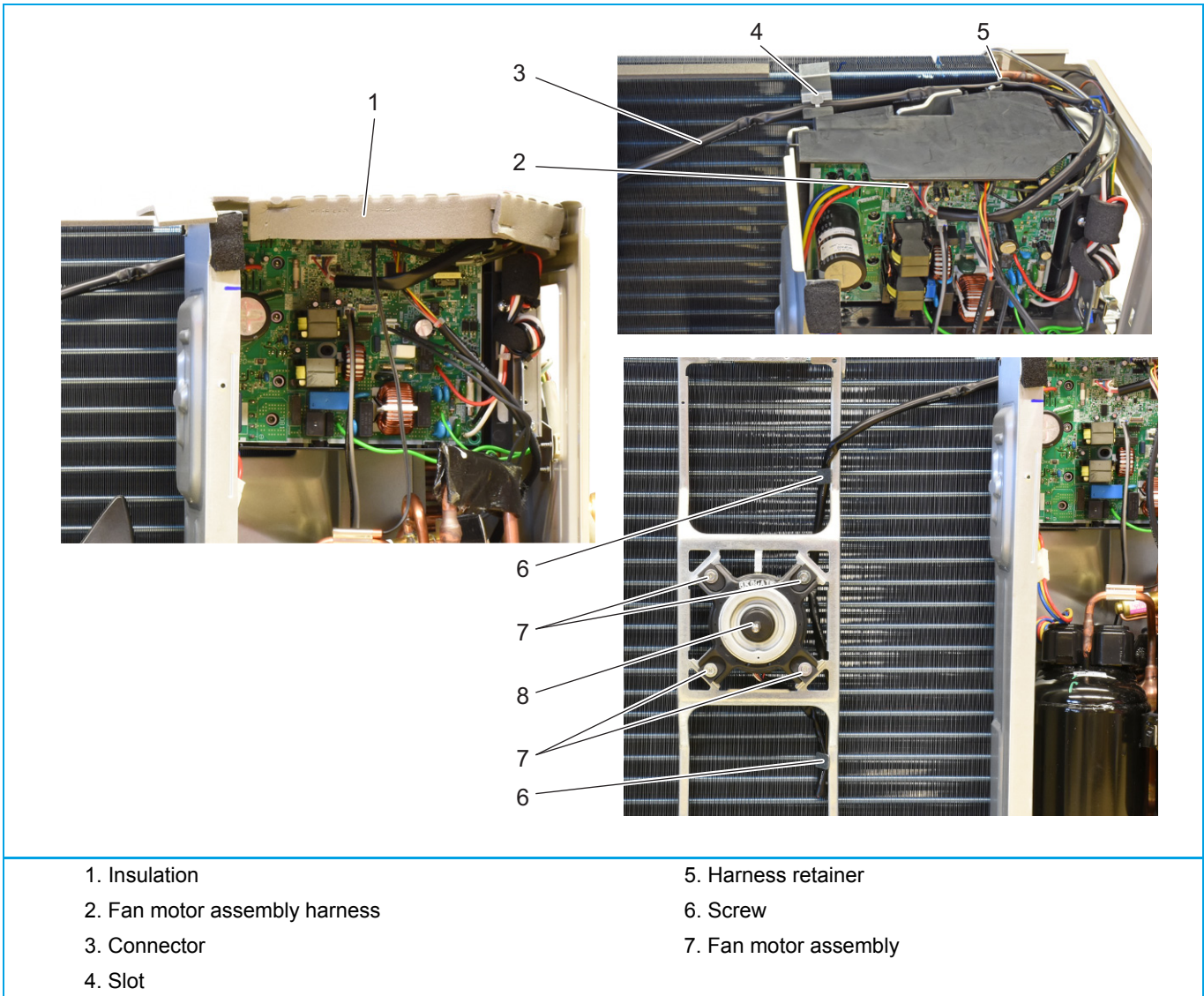

Installation

1. Proceed in reverse order.

3.3.2.7. Replacing expansion valve body

PRELIMINARY ACTIONS

1. Switch off the Daikin unit via the user interface.
2. Switch off the Daikin unit with the field supplied circuit breaker.
3. Remove the expansion valve motor, refer to ["Replacing expansion valve motor" on page 78](#).
4. Remove plate work when required.
5. Remove any part that block the way to the expansion valve body.

PROCEDURE



INFORMATION

Follow local regulations and Daikin refrigerant repair procedures during the repair of your unit, refer to ["Refrigerant repair procedures" on page 57](#).



CAUTION

The maximum applied Nitrogen pressure must not exceed 0.02 MPa.

Removal

1. Recuperate the putty (1).
2. Using a pipe cutter, cut the expansion valve body pipes (2).
3. Remove the expansion valve body (3).

Figure 3-12: Removing the expansion valve

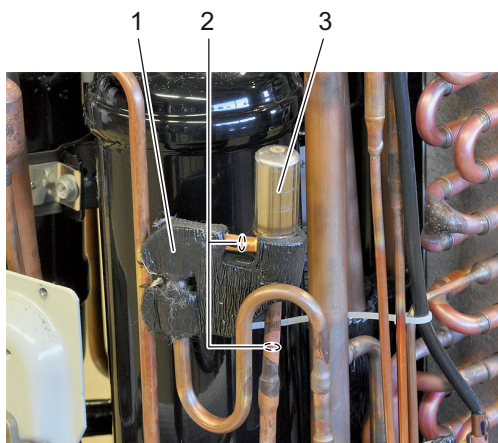

1. Putty
2. Expansion valve pipe

3. Expansion valve

Installation



WARNING

Overheating the expansion valve body will damage or destroy it.

1. Wrap a wet rag around the expansion valve body (3).



INFORMATION

Install the putty on the expansion valve body piping.

2. Proceed in reverse order.

3.3.2.8. Replacing expansion valve motor

PRELIMINARY ACTIONS

1. Switch off the Daikin unit via the user interface.
2. Switch off the Daikin unit with the field supplied circuit breaker.
3. Remove plate work when required.
4. Remove any part that block the way to the expansion valve motor.

PROCEDURE

Removal



WARNING: RISK OF FIRE

When reconnecting a connector to the PCB, do not apply force, as this may damage the connector or connector pins of the PCB.

1. Remove the expansion valve motor (1) from the expansion valve body (2).
2. Unplug expansion valve motor connector from PCB.
3. Cut all tie wraps that fix the expansion valve motor (1) wiring.

Figure 3-13: Removing the expansion valve motor

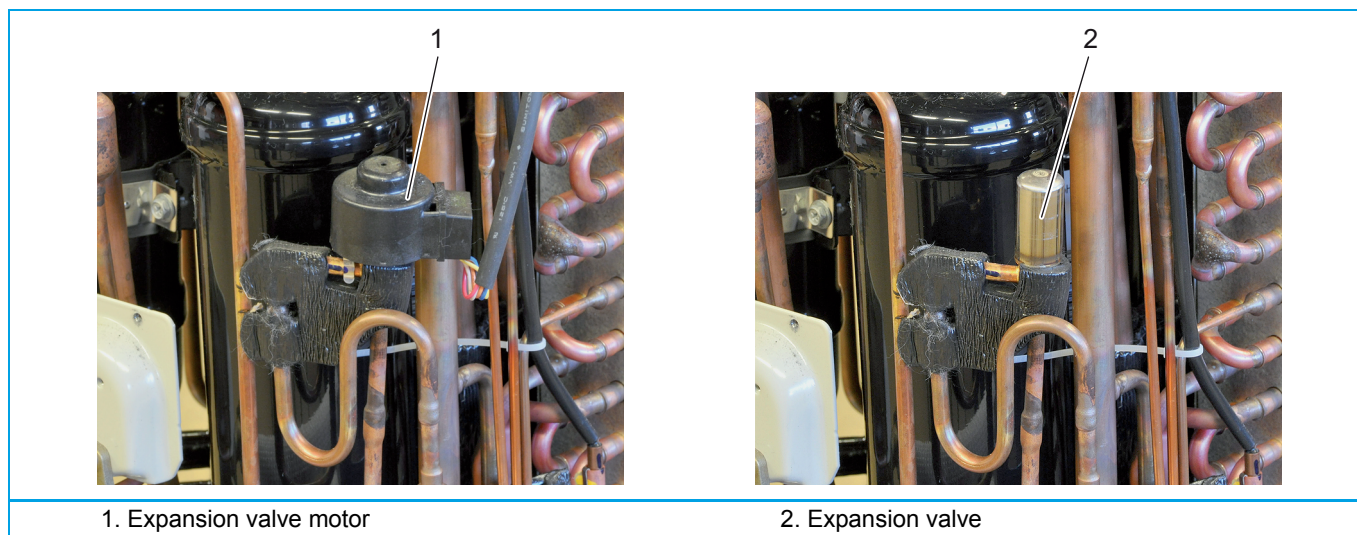

Installation



INFORMATION

Replace all tie wraps that were cut during removal.

1. Proceed in reverse order.



INFORMATION

The expansion valve motor (3) is equipped with a pipe retention clip (1). The pipe retention clip (1) must be placed over the pipe (2) to lock the expansion valve motor (3).

2. When installing the expansion valve motor (3), lock it on the expansion valve.

Figure 3-14: Locking the expansion valve motor

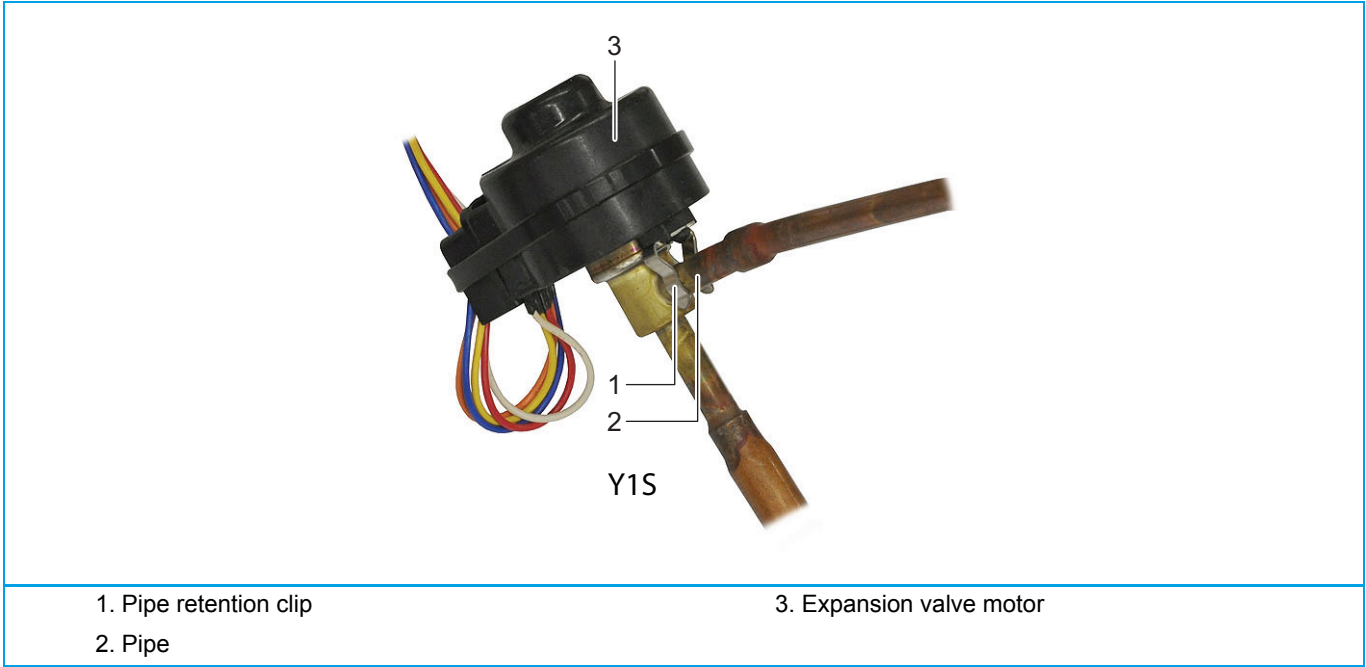

3.3.2.9. Replacing main PCB

PRELIMINARY ACTIONS

1. Switch off the Daikin unit via the user interface.
2. Switch off the Daikin unit with the field supplied circuit breaker.
3. Remove the switch box, refer to ["Replacing switch box" on page 67](#).

PROCEDURE

Removal

1. Cut the 2 cable ties (1).
2. Loosen and remove the screw (2).
3. Loosen and remove the 5 screws (3).
4. Press the 2 latches (5) to unlock and remove the main PCB (4).

Figure 3-15: Removing the main PCB

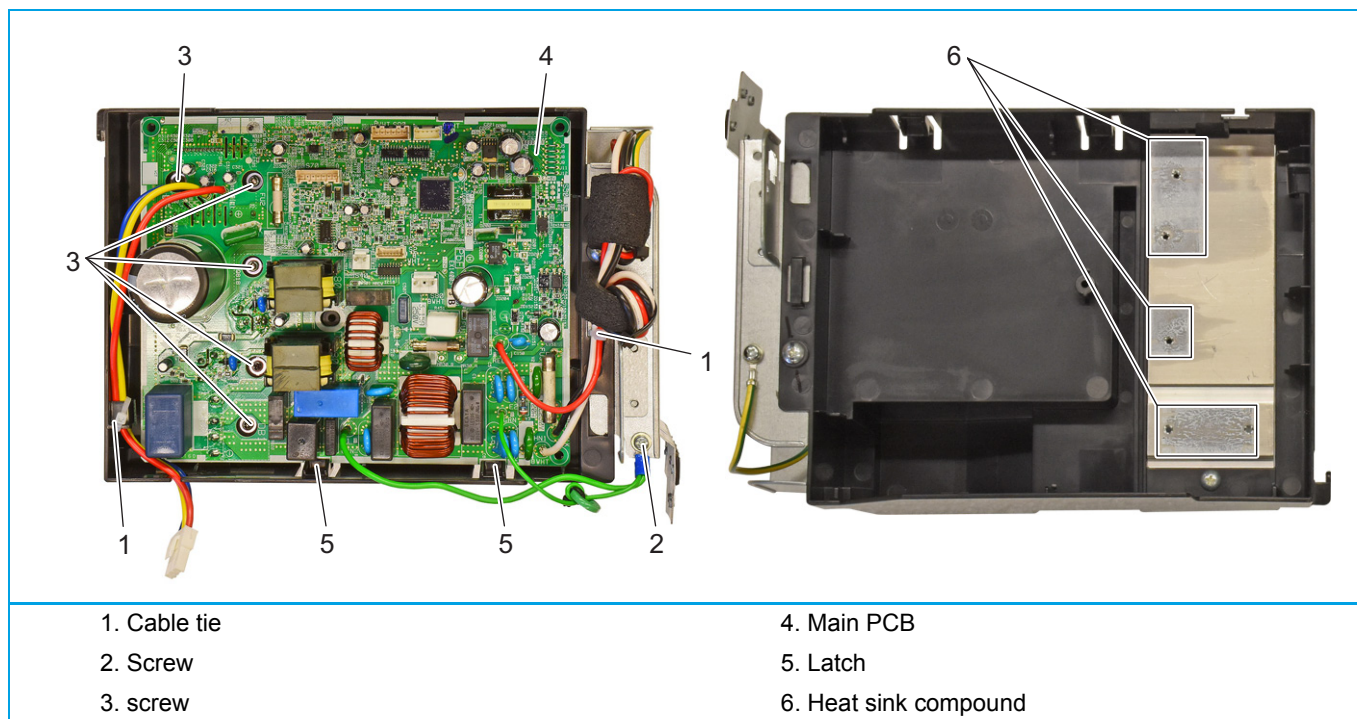

Installation

1. Apply Heat sink compound (6) before joining the main PCB and the heat sink.
2. Proceed in reverse order.

3.3.2.10. Replacing propeller fan blade assembly

PRELIMINARY ACTIONS

1. Switch off the Daikin unit via the user interface.
2. Switch off the Daikin unit with the field supplied circuit breaker.
3. Remove plate work when required.

PROCEDURE

Removal

1. Remove the nut (1) that fixes the propeller fan blade assembly (2).
2. Pull the propeller fan blade assembly (2) from the fan motor assembly (3).

Figure 3-16: Removing the propeller fan blade assembly

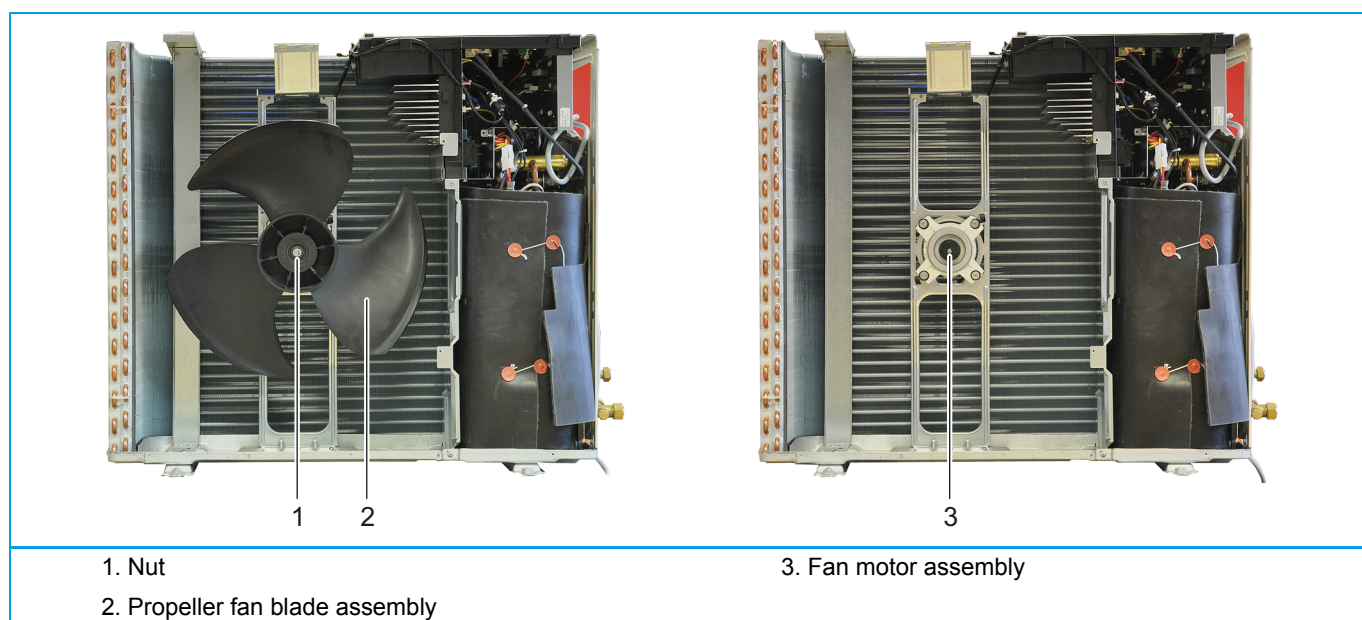

Installation



CAUTION

Do not install a damaged propeller.

1. Proceed in reverse order.

3.3.2.11. Replacing thermistors

PRELIMINARY ACTIONS

1. Switch off the Daikin unit via the user interface.
2. Switch off the Daikin unit with the field supplied circuit breaker.
3. Remove plate work when required, see "Basic removal" on page 64.

PROCEDURE

Removal

1. Locate thermistor that needs to be replaced, see "Component checklist" on page 101.
2. Cut the tie wraps (1) that fix the insulation (3) and the thermistor wire (2).
3. Cut the insulation (3) and remove it.
4. Pull the clip (5) that fixes the thermistor (6).
5. Remove the thermistor (6) from the thermistor holder (4).

Figure 3-17: Replacing a thermistor

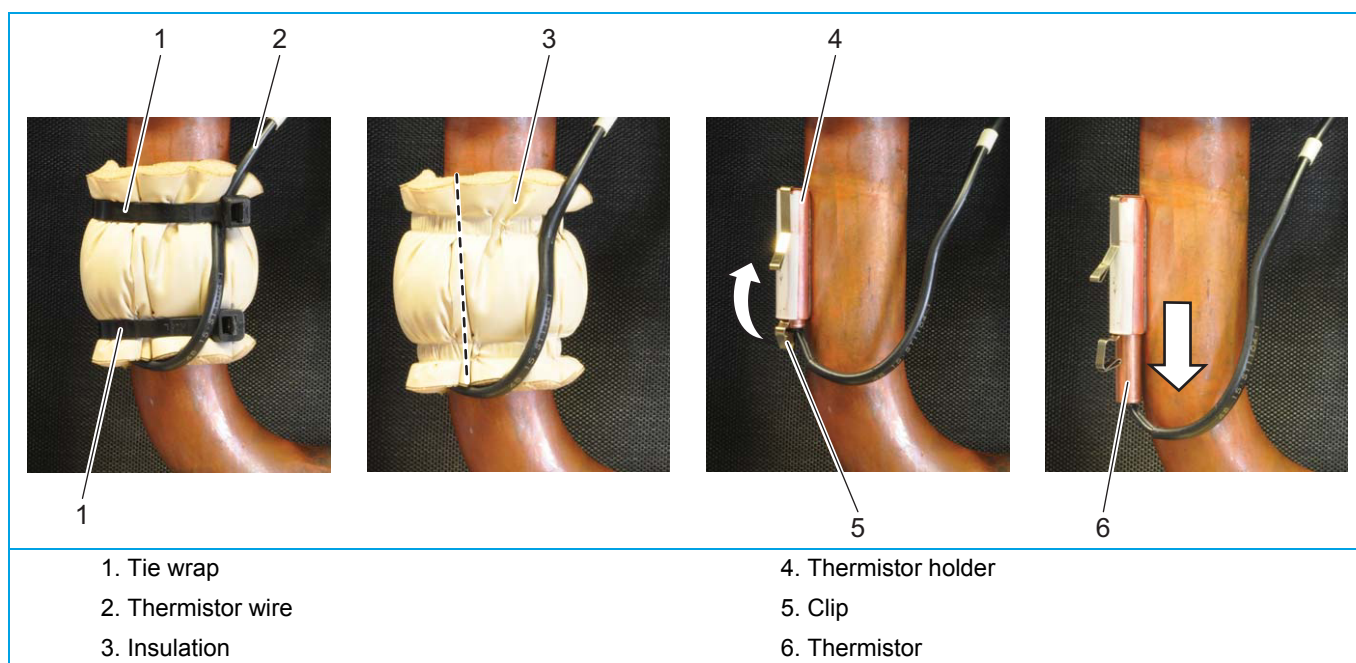

Installation

1. Proceed in reverse order.

3.3.2.12. Setting test mode for inverter checker

1. Turn off the power of the unit.
2. Connect the wires leading to compressor to the inverter analyzer.
3. Turn on the power of the unit.
4. Wait at least 3 minutes before starting the test (guard timer).
5. Press SW1 for approx. 5 seconds until you hear a click (relay).
6. About 5 seconds later all LED'S will start flashing.
7. Press the on/off button on the remocon once to stop the test.

Part 4. Maintenance

This part contains the following chapters:

Indoor unit	85
Outdoor unit.....	86

4.1. Indoor unit

	<p>WARNING</p> <p>Before performing any maintenance, power off the unit.</p>
---	---

	<p>INFORMATION</p> <p>After all checks are made, make sure the water and brine circuits are filled properly again and fluid pressures are in line with regulations (± 2 bar).</p>
---	--

4.1.1. General maintenance

1. Optimal operation conditions

	Cooling	Heating
Differential between suction temperature and discharge temperature	8~18°C	14~30°C
DB	27°C	20°C
WB	19°C	Not applicable

2. Correlation of air-conditioner's operation status, pressure and running current

COOLING	Low pressure	High pressure	Running current
Dirty air filter	Lower	Lower	Lower
Short circuit of air inlet/outlet	Lower	Lower	Lower
Air mixed in refrigerant	Higher	Higher	Higher
Water mixed in refrigerant	Lower*	Lower	Lower
Dirt mixed in refrigerant	Lower**	Lower	Lower
Refrigerant shortage (gas)	Lower	Lower	Lower
Unsatisfactory compression	Higher***	Lower	Lower

* Water in the refrigerant freezes inside the electronic expansion valve and is basically the same phenomenon as pump down.

** Dirt in the refrigerant clogs filters inside the piping and is basically the same phenomenon as pump down.

*** Pressure differential between high and low pressure becomes low.

4.2. Outdoor unit

4.2.1. General maintenance outdoor unit

1. Outdoor unit coil
 - Straighten hair fins.
 - Clear coil from dust, leaves, etc. with a fin-comb, or compressed air/N₂. Avoid bending or damaging of the Alu fins during the cleaning process.
 - Remove the icicles during winter season. Use gloves to avoid injury and unit damage.

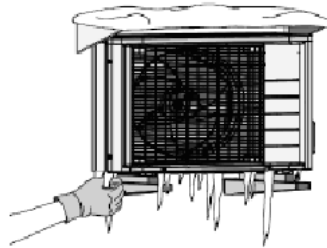

CAUTION

Make sure not to bend the hair fins.

2. Correlation of air-conditioner's operation status, pressure and running current.

COOLING	Low pressure	High pressure	Running current
Dirty air filter	Higher	Higher	Higher
Short circuit of air inlet/outlet	Higher	Higher	Higher
Air mixed in refrigerant	Higher	Higher	Higher
Water mixed in refrigerant	Lower*	Lower	Lower
Dirt mixed in refrigerant	Lower**	Lower	Lower
Refrigerant shortage (gas)	Lower***	Lower	Lower

* Water in the refrigerant freezes inside the electronic expansion valve and is basically the same phenomenon as pump down.

** Dirt in the refrigerant clogs filters inside the piping and is basically the same phenomenon as pump down.

*** Pressure differential between high and low pressure becomes low.

Part 5. Appendix

This part contains the following chapters:

Field setting	89
Detailed information setting mode	91
Wiring diagram	92
Piping diagram	98
Component overview of unit	100
Product specific information	101
Switch box	101
Field information report	102

5.1. Field setting

5.1.1. Indoor unit

5.1.1.1. Indoor fan control during thermostat off in cooling

Model: FTXM-M / Remote controller: ARC466A33

Software logic change for thermostat OFF is for cooling operation (to increase SEER) (for main stream models FTXM/CTXM).

Figure 5-1: How to change fan OFF to ON when in cooling thermo off

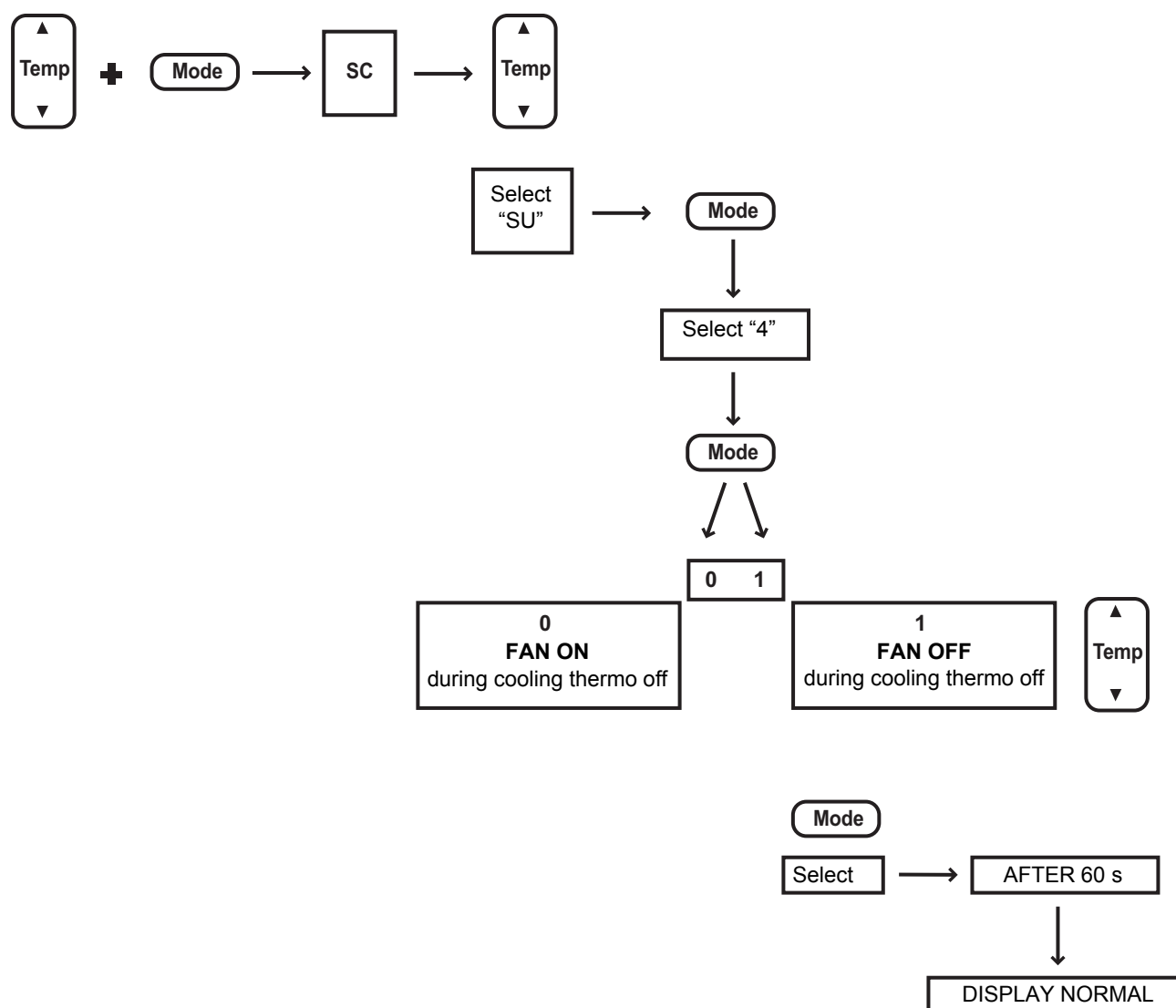

5.1.1.2. Brightness setting of multi-coloured lamp of the indoor unit

1. Press TEMP and MODE buttons simultaneously.
2. SC is displayed on the screen.
3. Select L (light) with TEMP buttons up or down.
4. Press MODE button to enter brightness setting mode.
5. Press TEMP up or down to adjust brightness to L (low), H (high) or OFF.
6. Press MODE button again for 5 seconds to exit.

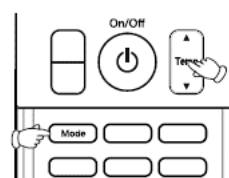

5.1.1.3. ON/OFF button on the indoor unit

1. Shortly press ON/OFF button indoor: auto, 25°C, auto fanspeed. To de-activate: shortly press ON/OFF again.
2. Press ON/OFF button indoor 5-9 seconds: forced operation mode = forced cooling. To de-activate: press again for 10 seconds.

5.1.1.4. Heat only mode

1. Please stop unit before setting.
2. How to switch H/O mode.

Remote controller: ARC466A33/ARC466A58

Figure 5-2: Heat only mode

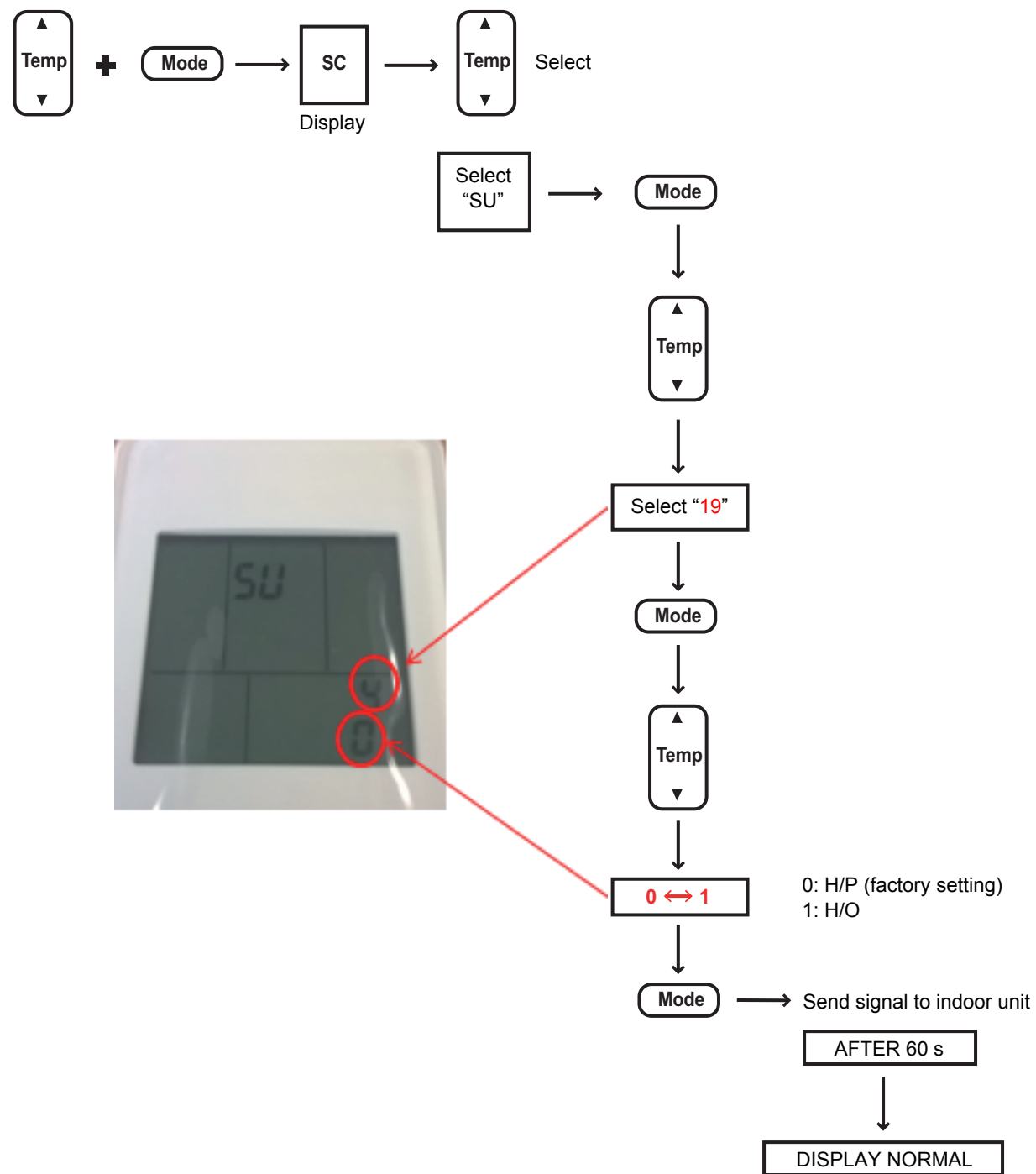

5.1.2. Outdoor unit

Not applicable.

5.1.3. Remote controller

Not applicable.

5.2. Detailed information setting mode

5.2.1. Indoor unit

Not available.

5.2.2. Outdoor unit

Not available.

5.2.3. Remote controller

Not available.

5.3. Wiring diagram

5.3.1. Indoor unit

5.3.1.1. FDXM-F9

Figure 5-3: Wiring diagram - indoor unit FDXM-F9

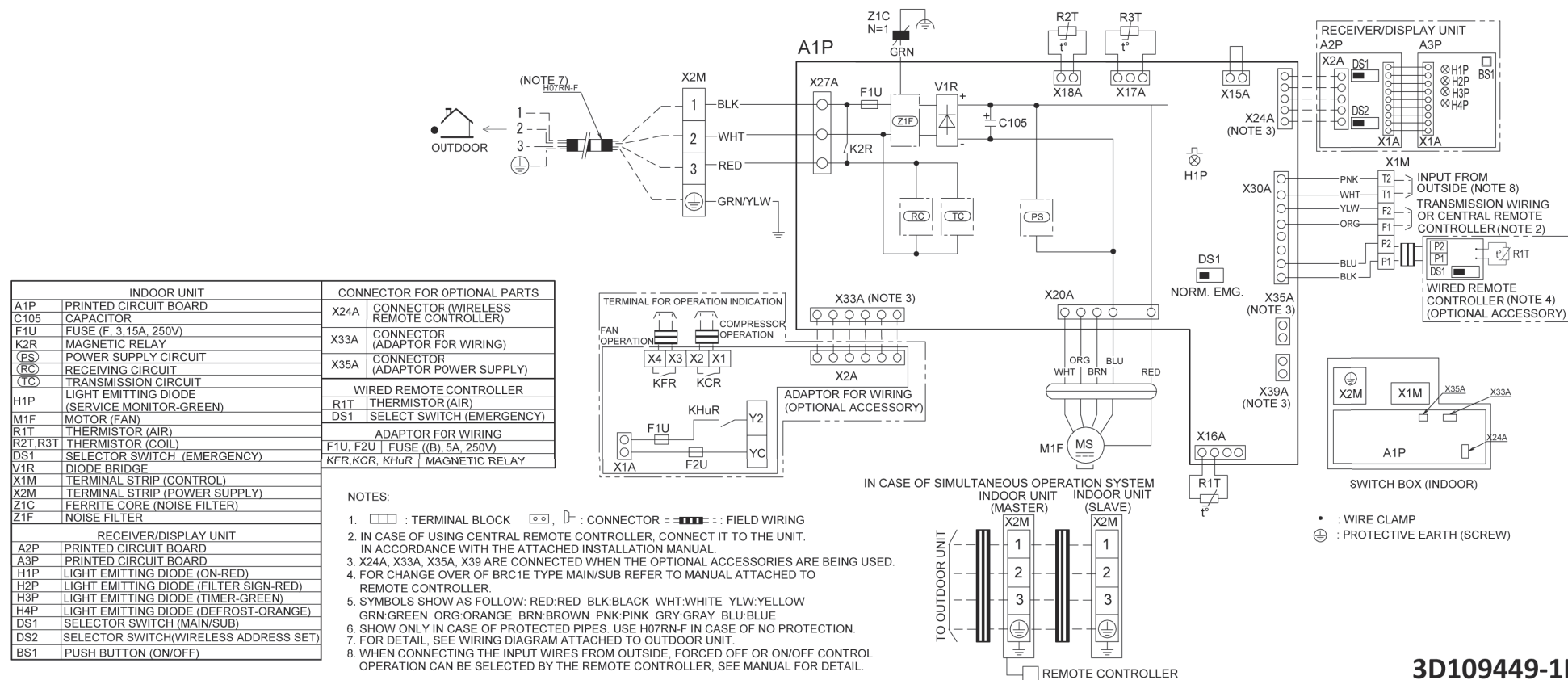

3D109449-1B

5.3.1.2. FFA-A9

Figure 5-4: Wiring diagram - indoor unit FFA-A9

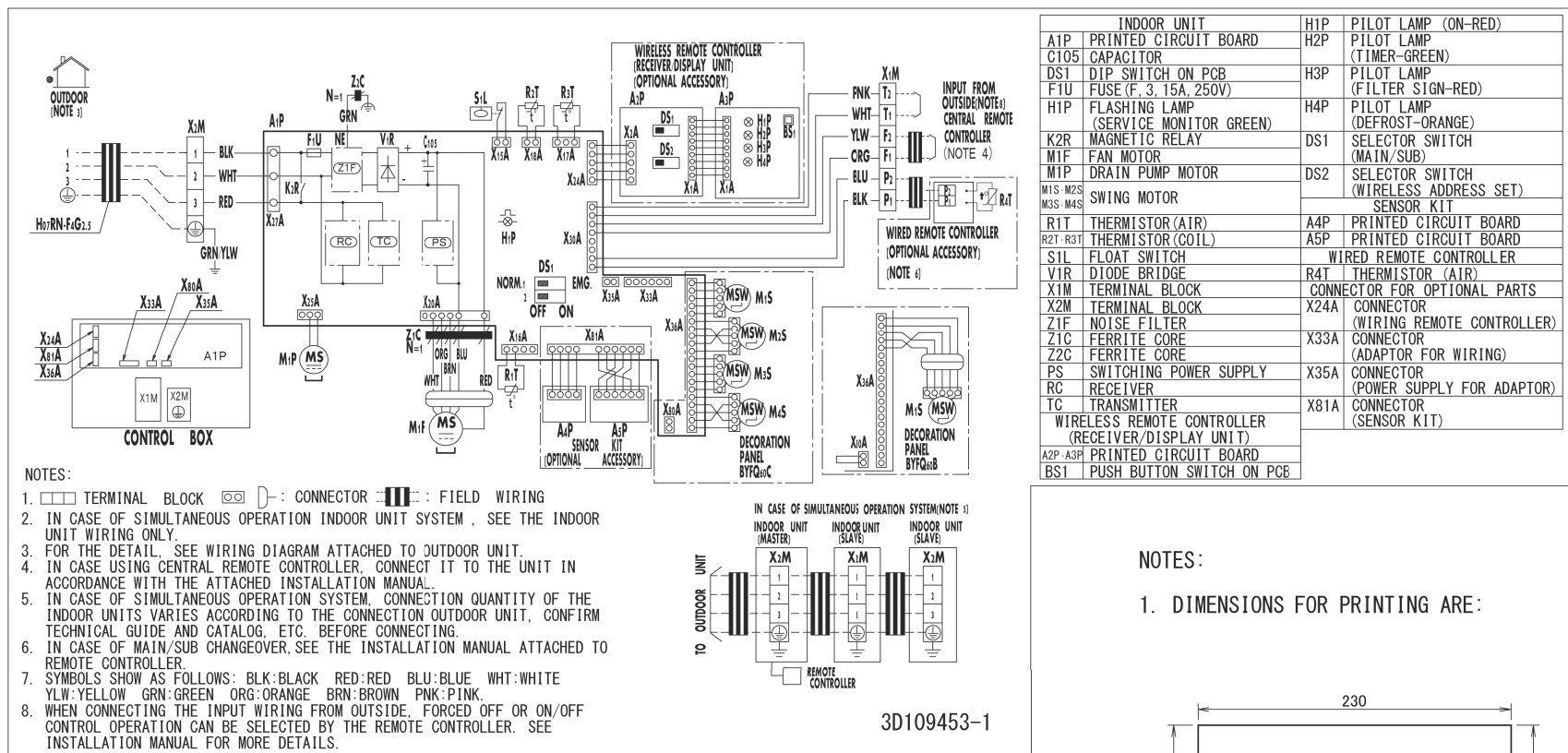

3D109453-1

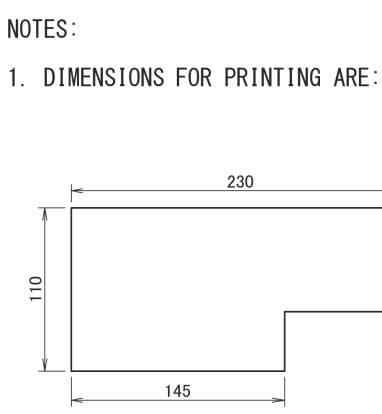

3D109453A

5.3.1.3. FBA-A9

Figure 5-5: Wiring diagram - indoor unit FBA-A9

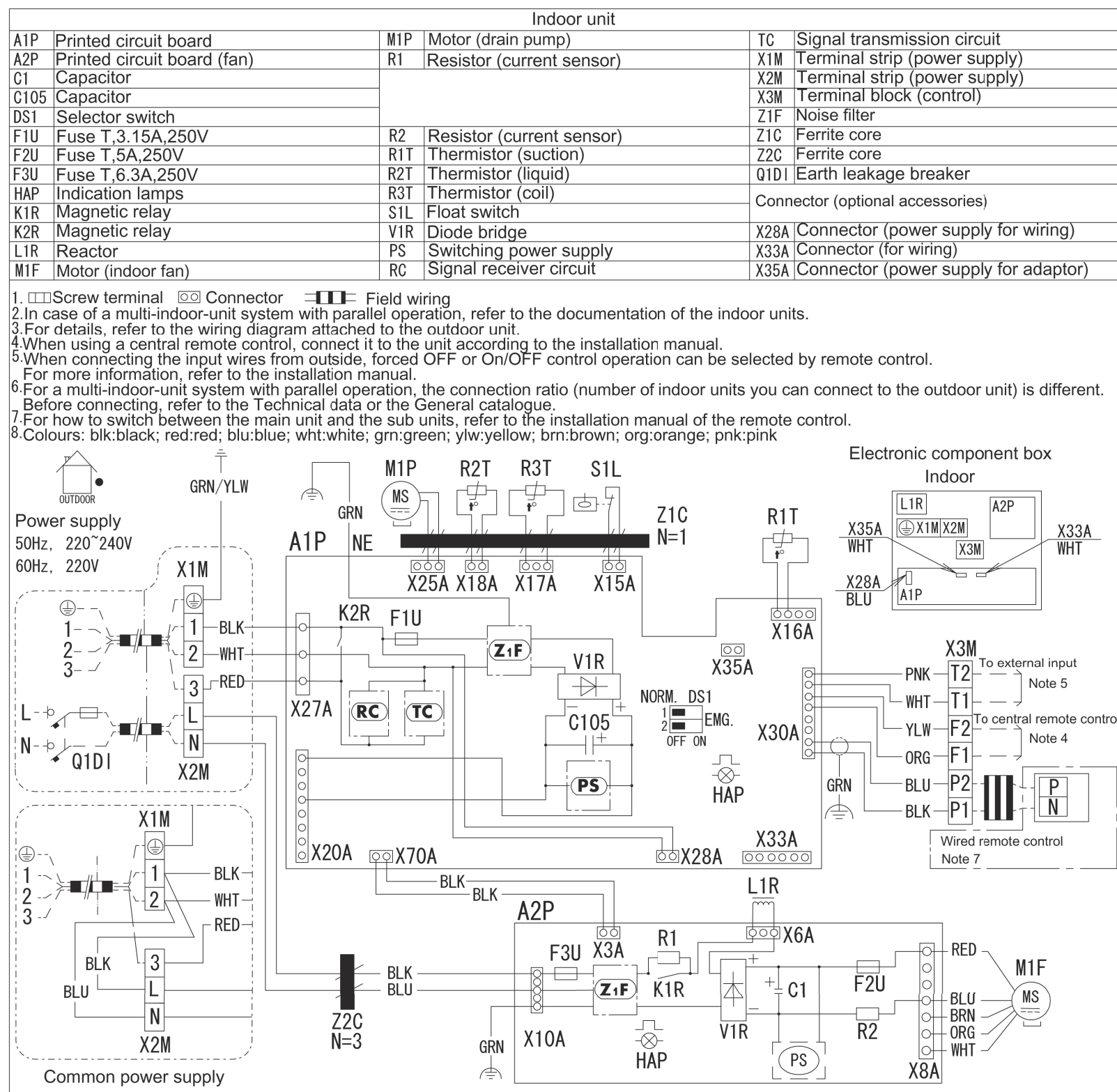

3D090350C

5.3.1.4. FCAG-B

Figure 5-6: Wiring diagram - indoor unit FCAG-B

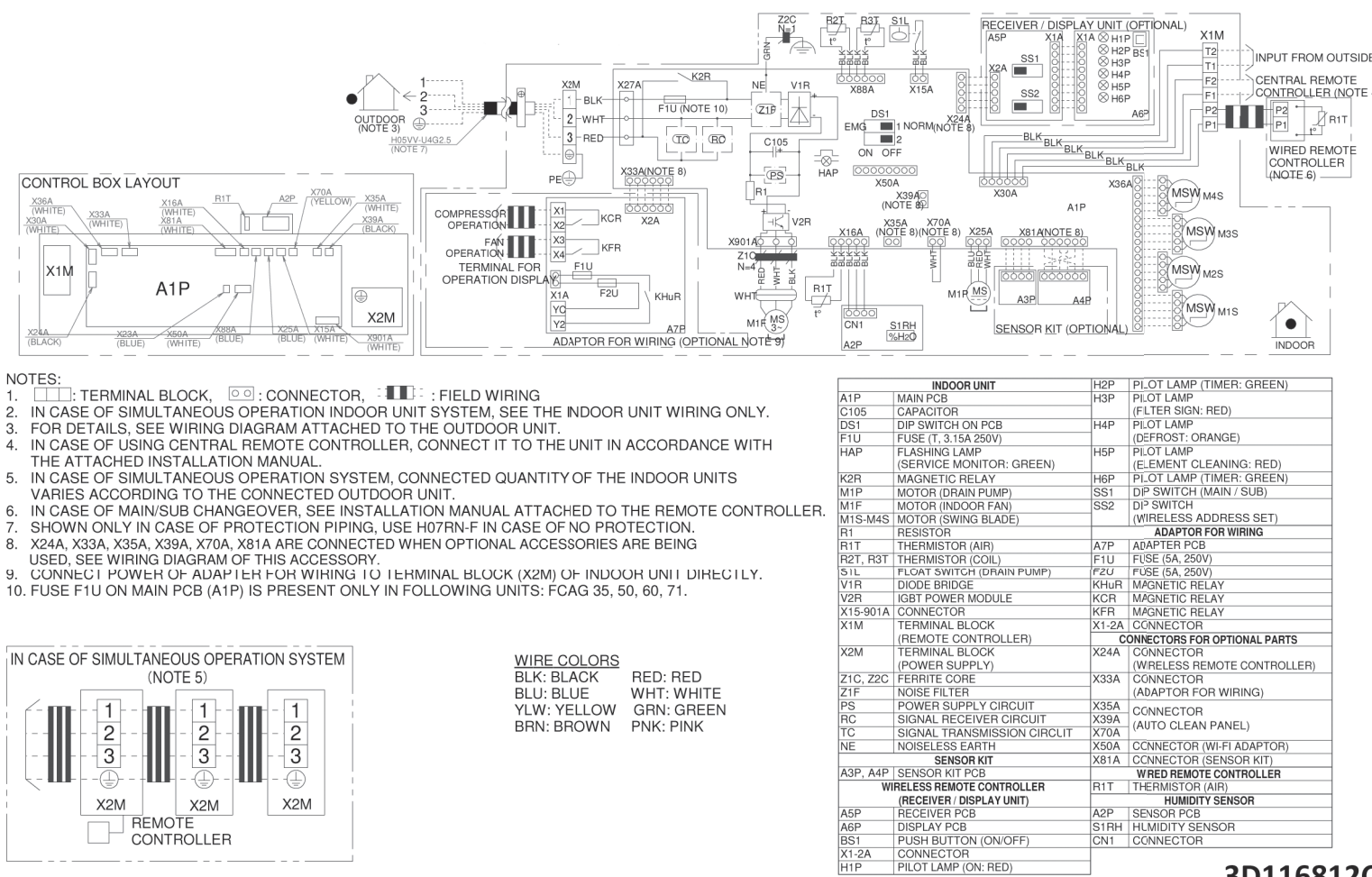

- NOTES:
1. [Symbol]: TERMINAL BLOCK, [Symbol]: CONNECTOR, [Symbol]: FIELD WIRING
 2. IN CASE OF SIMULTANEOUS OPERATION INDOOR UNIT SYSTEM, SEE THE INDOOR UNIT WIRING ONLY.
 3. FOR DETAILS, SEE WIRING DIAGRAM ATTACHED TO THE OUTDOOR UNIT.
 4. IN CASE OF USING CENTRAL REMOTE CONTROLLER, CONNECT IT TO THE UNIT IN ACCORDANCE WITH THE ATTACHED INSTALLATION MANUAL.
 5. IN CASE OF SIMULTANEOUS OPERATION SYSTEM, CONNECTED QUANTITY OF THE INDOOR UNITS VARIES ACCORDING TO THE CONNECTED OUTDOOR UNIT.
 6. IN CASE OF MAIN/SUB CHANGE-OVER, SEE INSTALLATION MANUAL ATTACHED TO THE REMOTE CONTROLLER.
 7. SHOWN ONLY IN CASE OF PROTECTION PIPING, USE H07RN-F IN CASE OF NO PROTECTION.
 8. X24A, X33A, X35A, X39A, X70A, X81A ARE CONNECTED WHEN OPTIONAL ACCESSORIES ARE BEING USED. SEE WIRING DIAGRAM OF THIS ACCESSORY.
 9. CONNECT POWER OF ADAPTOR FOR WIRING TO TERMINAL BLOCK (X2M) OF INDOOR UNIT DIRECTLY.
 10. FUSE F1U ON MAIN PCB (A1P) IS PRESENT ONLY IN FOLLOWING UNITS: FCAG 35, 50, 60, 71.

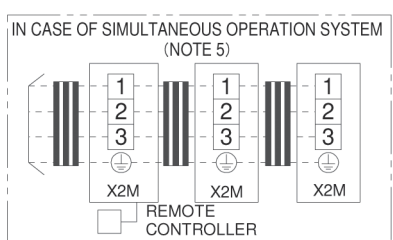

- WIRE COLORS
- BLK: BLACK
 - BLU: BLUE
 - YLW: YELLOW
 - BRN: BROWN
 - RED: RED
 - WHT: WHITE
 - GRN: GREEN
 - PNK: PINK

INDOOR UNIT		ADAPTOR FOR WIRING	
A1P	MAIN PCB	H2P	PILOT LAMP (TIMER: GREEN)
A2P	PRINTED CIRCUIT BOARD (FAN)	H3P	PILOT LAMP (FILTER SIGN: RED)
C105	CAPACITOR	H4P	PILOT LAMP (DEFROST: ORANGE)
DS1	DIP SWITCH ON PCB	H5P	PILOT LAMP (ELEMENT CLEANING: RED)
F1U	FUSE (T, 3.15A 250V)	H6P	PILOT LAMP (TIMER: GREEN)
HAP	FLASHING LAMP (SERVICE MONITOR: GREEN)	SS1	DIP SWITCH (MAIN / SUB)
K2R	MAGNETIC RELAY	SS2	DIP SWITCH (WIRELESS ADDRESS SET)
M1P	MOTOR (DRAIN PUMP)	RECEIVER / DISPLAY UNIT (OPTIONAL)	
M1F	MOTOR (INDOOR FAN)	A5P	RECEIVER PCB
M1S-M4S	MOTOR (SWING BLADE)	A6P	DISPLAY PCB
R1	RESISTOR	BS1	PUSH BUTTON (ON/OFF)
R1T	THERMISTOR (AIR)	X1-2A	CONNECTOR
R2T, R3T	THERMISTOR (COIL)	H1P	PILOT LAMP (ON: RED)
S1L	FLOAT SWITCH (DRAIN PUMP)	SENSOR KIT (OPTIONAL)	
V1R	DIODE BRIDGE	A2P	SENSOR PCB
V2R	IGBT POWER MODULE	S1RH	HMIDITY SENSOR
X15-901A	CONNECTOR	CN1	CONNECTOR
X1M	TERMINAL BLOCK (REMOTE CONTROLLER)	WIRELESS REMOTE CONTROLLER	
X2M	TERMINAL BLOCK (POWER SUPPLY)	R1T	THERMISTOR (AIR)
Z1C, Z2C	FERRITE CORE	HUMIDITY SENSOR	
Z1F	NOISE FILTER	A2P	SENSOR PCB
PS	POWER SUPPLY CIRCUIT	S1RH	HMIDITY SENSOR
RC	SIGNAL RECEIVER CIRCUIT	CN1	CONNECTOR
TC	SIGNAL TRANSMISSION CIRCUIT	CONNECTORS FOR OPTIONAL PARTS	
NE	NOISELESS EARTH	X24A	CONNECTOR (WIRELESS REMOTE CONTROLLER)
SENSOR KIT		X33A	CONNECTOR (ADAPTOR FOR WIRING)
A3P, A4P	SENSOR KIT PCB	X35A	CONNECTOR (WI-FI ADAPTOR)
WIRELESS REMOTE CONTROLLER (RECEIVER / DISPLAY UNIT)		X39A	CONNECTOR (AUTO CLEAN PANEL)
A5P	RECEIVER PCB	X70A	CONNECTOR (WI-FI ADAPTOR)
A6P	DISPLAY PCB	X81A	CONNECTOR (SENSOR KIT)
BS1	PUSH BUTTON (ON/OFF)	WIRED REMOTE CONTROLLER	
X1-2A	CONNECTOR	R1T	THERMISTOR (AIR)
H1P	PILOT LAMP (ON: RED)	HUMIDITY SENSOR	

3D116812C

5.3.1.5. FNA-A9

Figure 5-7: Wiring diagram - indoor unit FNA-A9

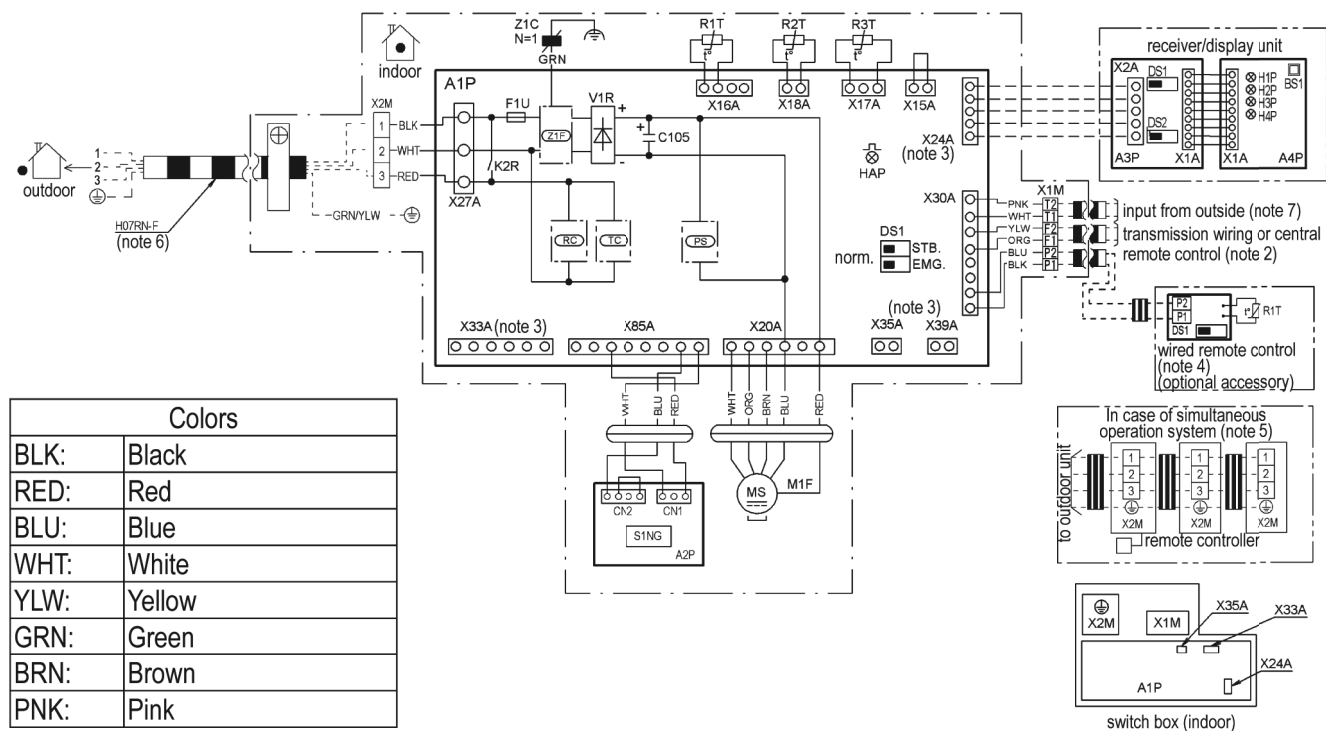

Indoor unit		Z1F	Noise filter
A1P	Printed circuit board	Receiver/display unit	
A2P	Gas sensor board	A3P	Printed circuit board
C105	Capacitor	A4P	Printed circuit board
F1U	Fuse (F, 3.15A, 250V)	H1P	Light emitting diode (on-red)
K2R	Magnetic relay	H2P	Light emitting diode (filter sign-red)
PS	Power supply circuit	H3P	Light emitting diode (timer-green)
RC	Receiving unit	H4P	Light emitting diode (defrost-orange)
TC	Transmission circuit	DS1	Selector switch (main/sub)
HAP	Light emitting diode (service monitor-green)	DS2	Selector switch (wireless address set)
M1F	Motor (fan)	BS1	Push button (on/off)
R1T	Thermistor (air)	Connector for optional parts	
R2T, R3T	Thermistor (coil)	X24A	Connector (infrared remote control)
DS1	Selector switch (emergency)	X33A	Connector (adapter for wiring)
V1R	Diode bridge	X35A	Connector (adapter power supply)
X1M	Terminal strip (control)	Wired remote control	
X2M	Terminal strip (power supply)	R1T	Thermistor (air)
Z1C	Ferrite core (noise filter)	SS1	Selector switch (emergency)

NOTES

- : terminal block, □□: connector, - - - - - : field wiring, •: wire clamp, ⊕: protective earth (screw)
- In case of using central remote control, connect it to the unit in accordance with the attached installation manual.
- X24A, X33A, X35A, X39 are connected when the optional accessories are being used.
- For change over of BRC1E type main/sub refer to manual attached to remote control.
- Show only in case of protected pipes. Use H07RN-F in case of no protection.
- For detail, see wiring diagram attached to outdoor unit.
- When connecting the input wires from outside, forced OFF or ON/OFF control operation can be selected by the remote control, see manual for detail.

3D111023A

5.3.1.6. FTXM-M

Figure 5-8: Wiring diagram - indoor unit FTXM-M

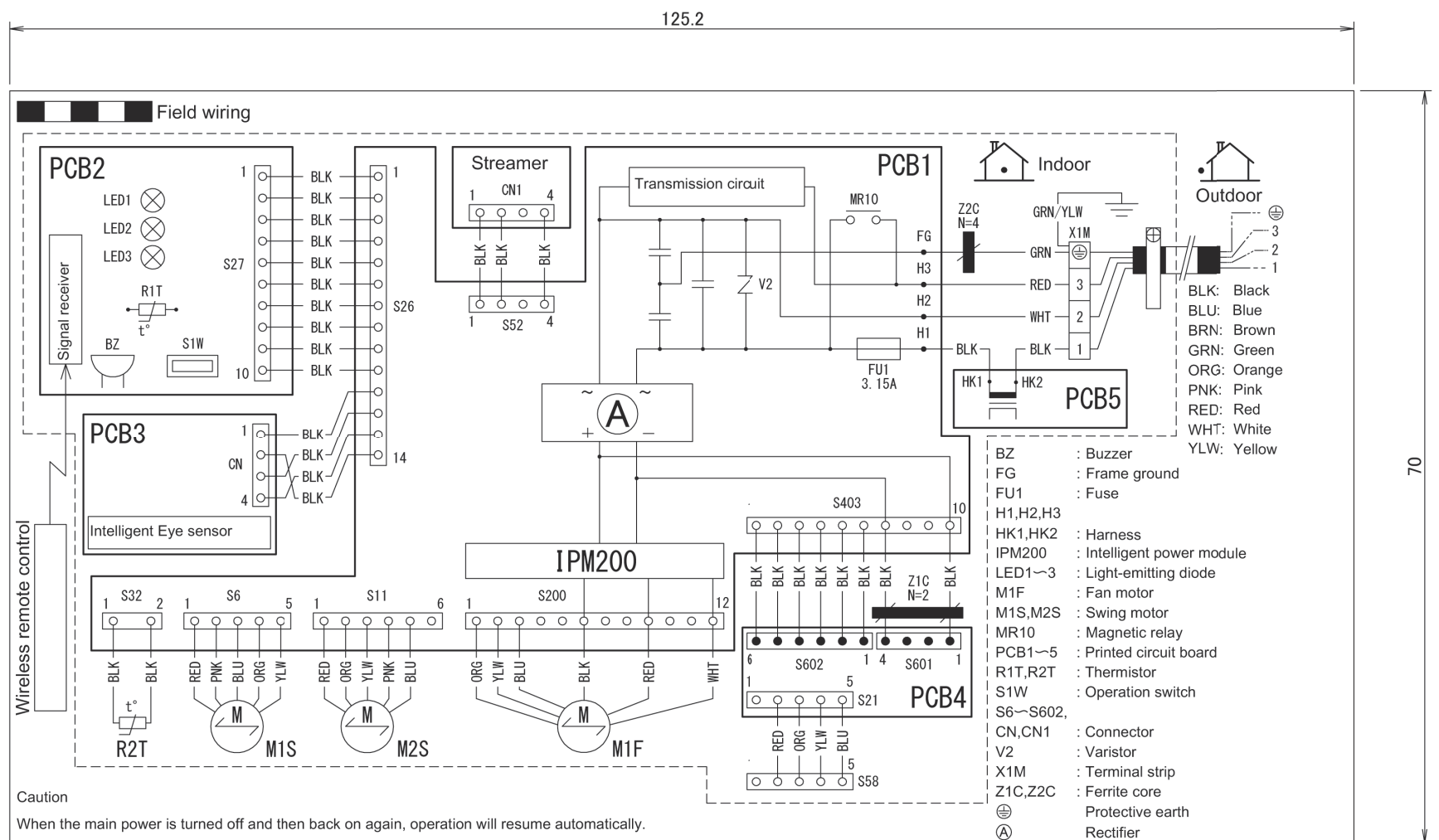

Notes

- 1) Size: length 70 X width 120.
- 2) Refer to purchasing specification AS303002, unless otherwise specified.

3D098117C

5.3.1.7. FHA-A9

Figure 5-9: Wiring diagram - indoor unit FHA-A9

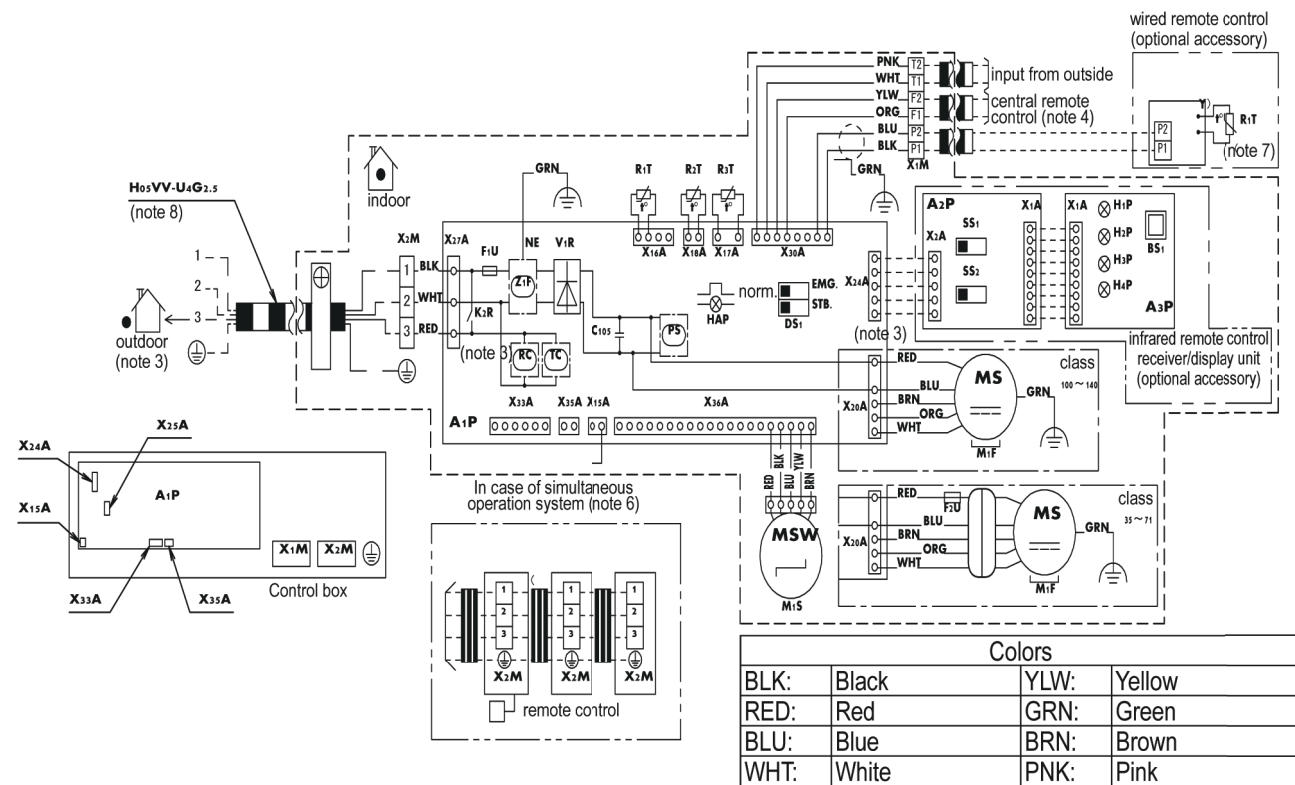

Indoor unit		TC	Signal transmission circuit
A1P	Printed circuit board		Wired remote control
C105	Capacitor (M1F)	R1T	Thermistor (air)
F1U	Fuse (F, 5A, 250V)		Infrared remote control (receiver/display unit)
F2U	Fuse (F, 4A, 500V)	A2P	Printed circuit board
DS1	Dip switch on PCB	A3P	Printed circuit board
HAP	Flashing lamp (service monitor: green)	BS1	Push button (on/off)
K2R	Magnetic relay	H1P	Pilot lamp (on: red)
M1F	Motor (indoor fan)	H2P	Pilot lamp (timer: green)
M1S	Motor (swing blade)	H3P	Pilot lamp (filter sign: red)
R1T	Thermistor (air)	H4P	Pilot lamp (defrost: orange)
R2T-R3T	Thermistor (coil)	SS1	Selector switch (main/sub)
V1R	Diode bridge	SS2	Selector switch (wireless address set)
X1M	Terminal block		Connector for optional parts
X2M	Terminal block	X15A	Connector (floatins switch)
Z1F	Noise filter	X24A	Connector (infrared remote control)
PS	Power supply circuit	X33A	Connector (adapter for wiring)
RC	Signal receiver unit	X35A	Connector (power supply for adapter)

NOTES

- : terminal block, □□: connector, ■■■■■: field wiring, □□□: short circuit connector
- In case of simultaneous operation indoor unit system, see the indoor unit wiring only. For the detail, see wiring diagram attached to outdoor unit.
- In case using central remote control, connect it to the unit in accordance with the attached installation manual.
- X15A, x25A are connected when the drain pump kit is being used.
- In case of simultaneous operation system, connected quantity of the indoor units varies according to the connection outdoor unit. Confirm technical guide and catalogue, etc. before connecting.
- In case of main/sub changeover see the installation manual attached to remote control.
- Shows only in case of protection piping, use H07RN-F in case of no protection.

3D110939

5.3.2. Outdoor unit

5.3.2.1. RZAG35/50/60A

Figure 5-10: Wiring diagram - outdoor unit RZAG35/50/60A

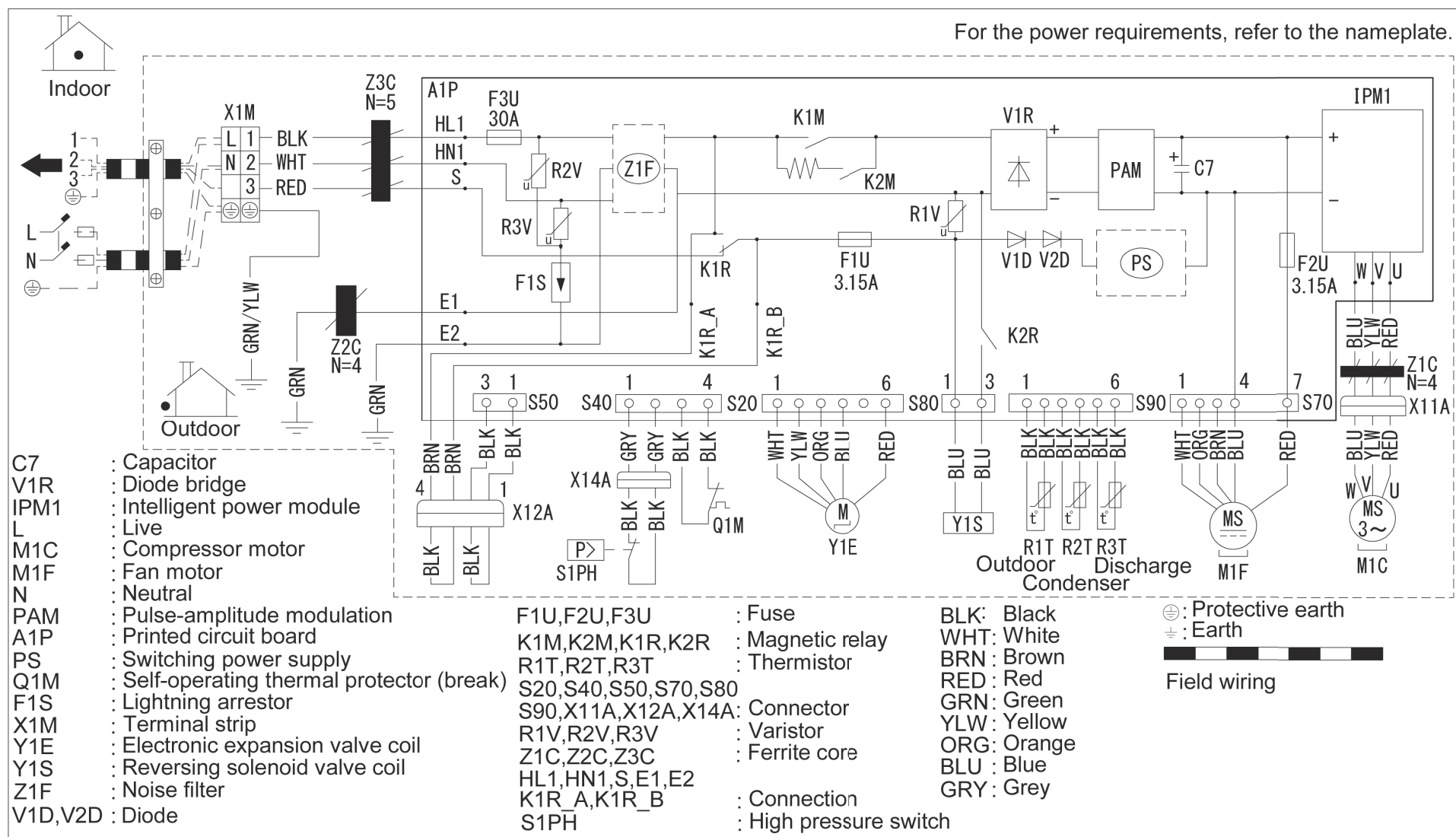

NOTES:

1. Size: length 105 x width 185.
2. Refer to purchasing specification AS303002 unless otherwise specified.

3D117016

5.3.3. Field wiring

Not applicable.

5.4. Piping diagram

5.4.1. Indoor unit

Figure 5-11: Piping diagram - indoor unit

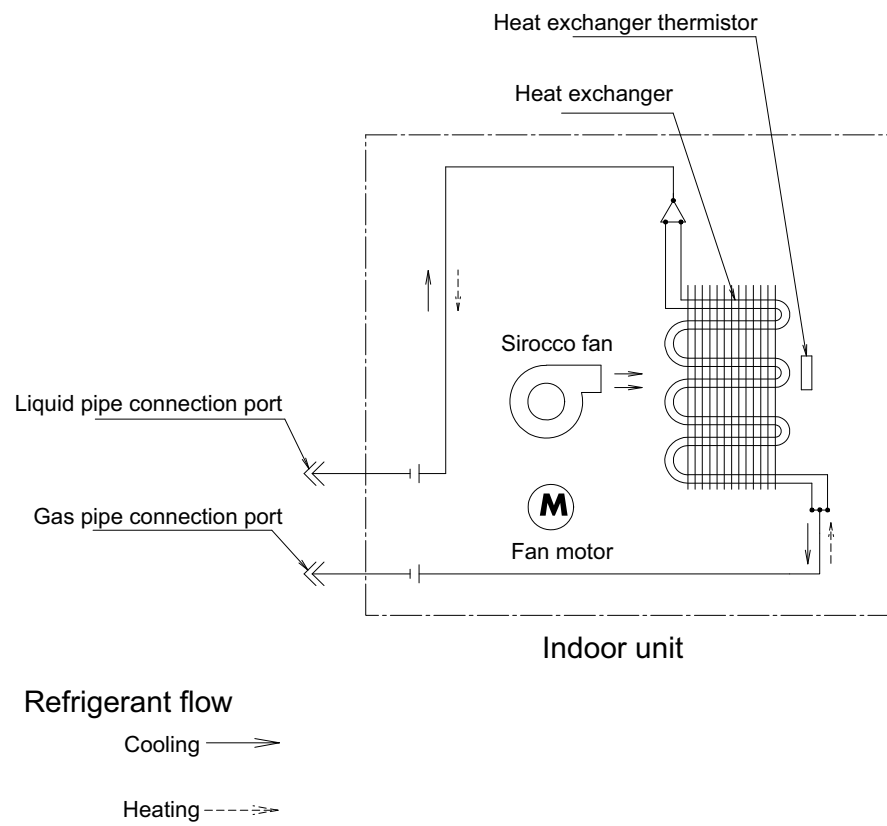

5.4.2. Outdoor unit

5.4.2.1. RZAG35A

Figure 5-12: Piping diagram - outdoor unit RZAG35A

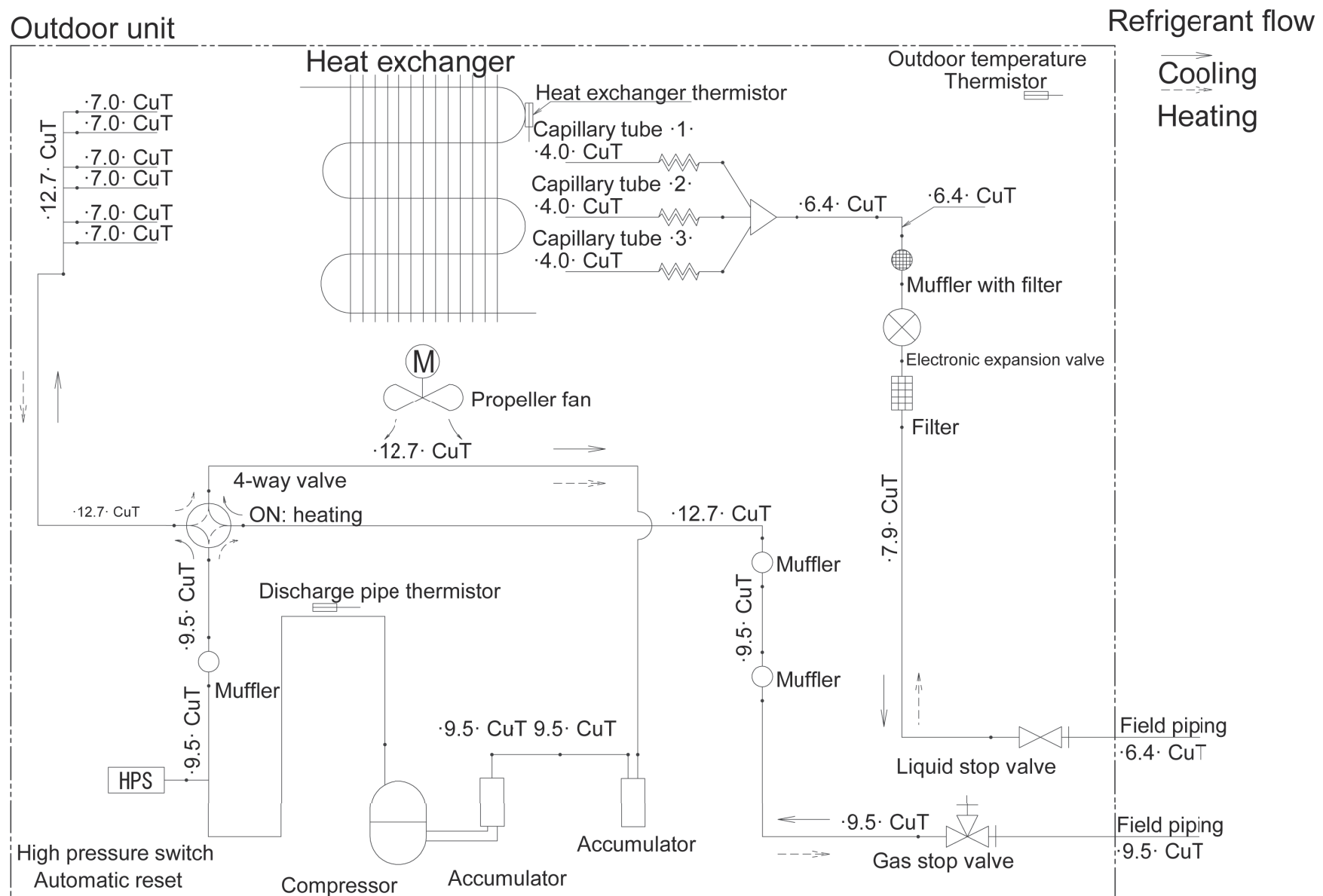

3D116991A

5.4.2.2. RZAG50/60A

Figure 5-13: Piping diagram - outdoor unit RZAG50/60A

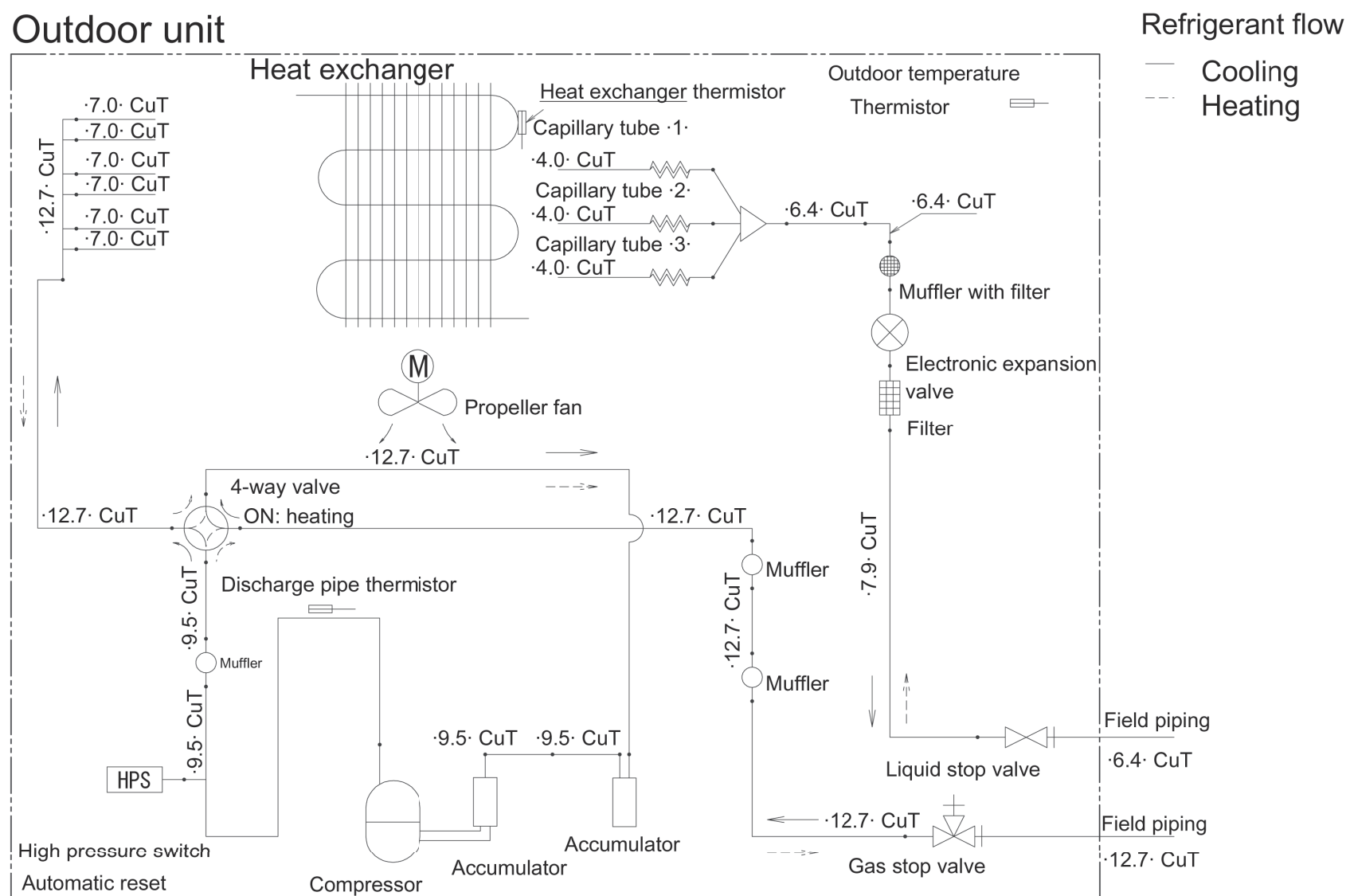

3D116990A

5.5. Component overview of unit

5.5.1. Indoor unit

Not available yet.

5.5.2. Outdoor unit

Figure 5-14: Component overview - outdoor unit

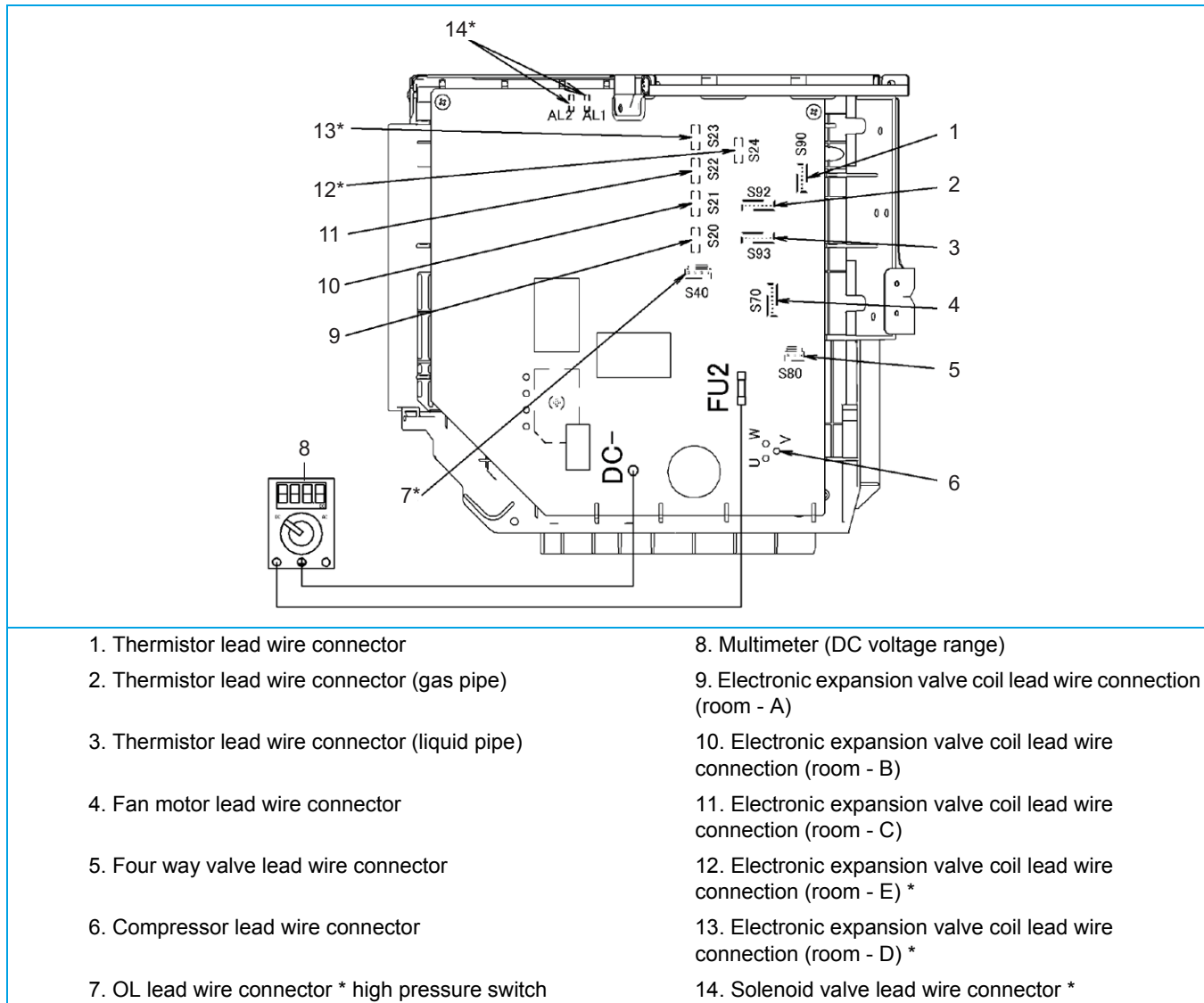

* may not be present depending on the model

5.6. Product specific information

5.6.1. Error codes

5.6.1.1. "E7-00" – Fan motor abnormality

Unit will automatically reset the error after a continuous run for 60 minutes without any other error code.

5.6.1.2. "EA-00" – Malfunction of 4-way valve

Set conditions

Room thermistor/indoor heat exchanger is not functioning within operation range.

Reset conditions

Continuous run for about 60 minutes without any other error.

5.6.1.3. "F3-00" – Discharge pipe temperature abnormality

Set conditions

If the discharge temperature detected is above A, the compressor stops.

Automatic reset conditions

Unit will automatically reset the error when the discharge temperature drops below B for 60 minutes without any other error.

Compressor frequency (Hz)	A (°C)	B (°C)
> 45 Hz and rising > 40 Hz and dropping	110	97
30~45 Hz and rising 25~40 Hz and dropping	105	92
< 30 Hz and rising < 25 Hz and dropping	99	86

5.6.1.4. "L3-00" – Switch box temperature abnormality

Set conditions

When the compressor is off, the radiation fin temperature is above 98 °C.

Automatic reset conditions

Unit will automatically reset the error when the radiation fin temperature drops below 75 °C for 60 minutes without any other error.

To cool the electrical components, the outdoor fan starts when the radiation fin temperature rises above 83 °C and stops when it drops below 75 °C.

5.6.1.5. "L4-00" – Inverter radiating fin temperature abnormality

Set conditions

When the compressor is ON, the radiation fin temperature is above 98 °C.

If the error repeats, the system is shut down.

Automatic reset conditions

Unit will automatically reset the error when the radiation fin temperature drops below 78 °C for 60 minutes without any other error.

5.6.2. Component checklist

Not available yet.

5.7. Switch box

5.7.1. Indoor unit

Not applicable.

5.7.2. Outdoor unit

Not available.

5.8. Field information report

See next page.

In case a problem occurred on the unit which could not be resolved by using the content of this service manual or in case you have a problem which could be resolved but of which the manufacturer should be notified, we advise you to contact your distributor.

To facilitate the investigation, additional information is required. Please fill out the following form before contacting your distributor.



FIELD INFORMATION REPORT

Key person info	
Name:	Company name:
Your contact details Phone number:	E-mail address:
Site address:	
Your reference:	Date of visit:

Claim info	
Title:	
Problem description:	
Error code:	Trouble date:
Problem frequency:	
Investigation steps done:	
Insert picture of the trouble.	
Current situation (solved, not solved, ...):	
Countermeasures taken:	
Comments and proposals:	
Part available for return (if applicable):	

Application info

Application (house, apartment, office, ...):

New project or refurbishment:

Heat emitters (radiators / under floor heating / fan coils / ...):

Hydraulic layout (simple schematic):

Unit / Installation info

Model name:

Serial number:

Installation / commissioning date:

Software version hydro PCB A1P:

Software version hydro PCB A5P:

Software version user interface:

Software version outdoor PCB:

Minimum water volume:

Maximum water volume:

Brine composition and mixture:

Brine freeze up temperature:

Space heating control (leaving water temperature, room thermostat, ext. room thermostat):

Space heating setpoint:

Domestic hot water control (reheat only, schedule only, reheat + schedule):

Domestic hot water setpoint:

Provide pictures of the field settings overview (viewable on the user interface).